

INGERSOLL

444
TRACTOR
Operator's Manual No. 9-2252

19-2252
OPERATOR'S MANUAL 444 TR
20504



casecoltingersoll.com





This Safety Alert Symbol Indicates Important Safety Messages In This Manual When You See This Symbol Carefully Read The Message That Follows and Be Alert To The Possibility Of Personal Injury Or Death

IF THIS MACHINE IS USED BY AN EMPLOYEE OR IS LOANED OR RENTED, MAKE ABSOLUTELY CERTAIN THAT THE OPERATOR(S), PRIOR TO OPERATING:

1. IS INSTRUCTED IN SAFE AND PROPER USE.
2. REVIEWS AND UNDERSTANDS THE MANUAL(S) PERTAINING TO THE MACHINE.

751253



WARNING

BEFORE STARTING ENGINE

STUDY OPERATOR'S MANUAL SAFETY MESSAGES
READ ALL SAFETY SIGNS ON MACHINE
CLEAR THE AREA OF OTHER PERSONS

LEARN & PRACTICE SAFE USE OF CONTROLS BEFORE OPERATING

IT IS YOUR RESPONSIBILITY TO UNDERSTAND AND FOLLOW MANUFACTURER'S INSTRUCTIONS, ON MACHINE OPERATION, SERVICE, AND TO OBSERVE PERTINENT LAWS AND REGULATIONS. OPERATOR AND SERVICE MANUALS MAY BE OBTAINED FROM YOUR EQUIPMENT DEALER.

TO THE PURCHASER OF A CASE TRACTOR

The care you give your new Case Tractor will greatly determine the satisfaction and service life you will obtain from it. Use this manual as your guide. By observing the instructions and suggestions in this manual, your Case Tractor will serve you well for many years.

As an Authorized Case Dealer, we stock Genuine Case Parts, which are manufactured with the same precision and skill as the original equipment. Our factory trained staff is kept well informed on the best methods of servicing Case equipment and is ready and able to help you.

Should you require additional aid or information, contact us.

Your Authorized Case Dealer

NOTE

THIS MANUAL APPLIES TO TRACTORS SERIAL NUMBER 9641001 AND AFTER.



LOOK FOR THIS SYMBOL
TO POINT OUT IMPORTANT
SAFETY PRECAUTIONS

To insure efficient and prompt service, please furnish us with the Model, Serial, Engine Model Number and Engine Specification Number of your Tractor in all correspondence or contacts.

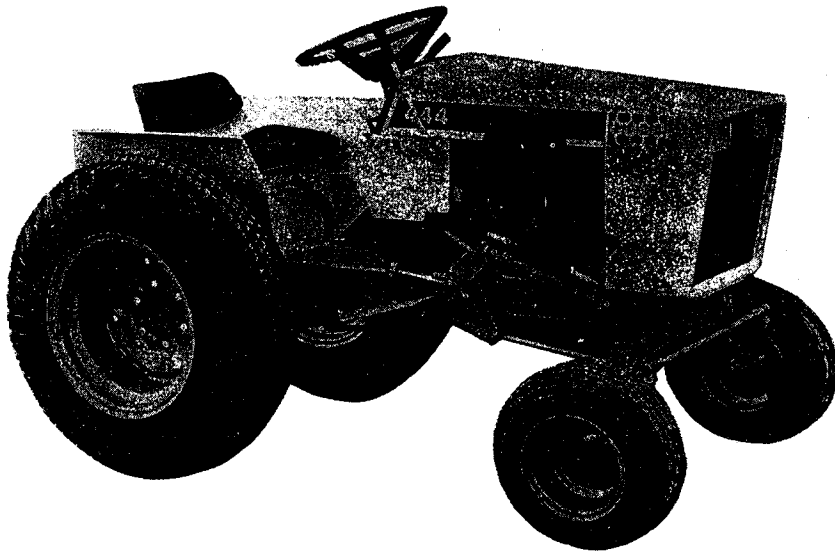

Figure 1. Right Hand View of Case 444 Compact Tractor

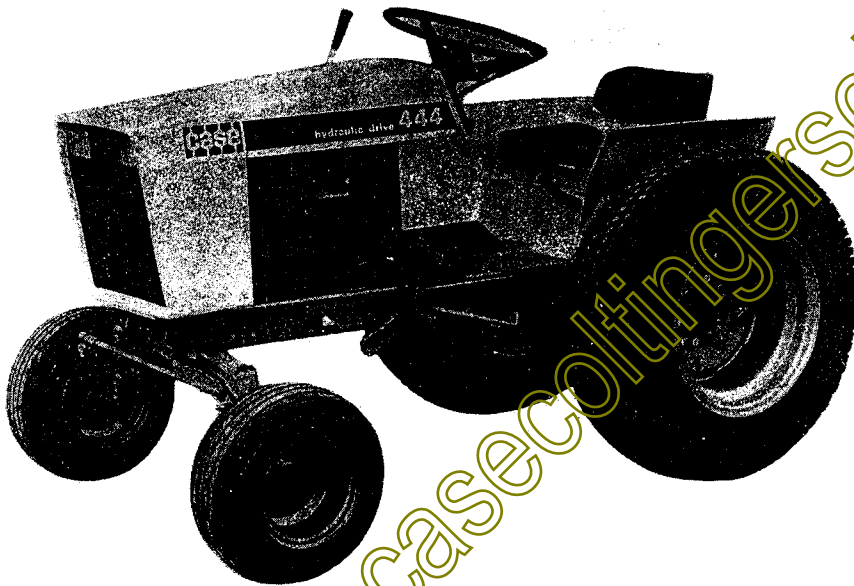

Figure 2. Left Hand View of Case 444 Tractor

SERIAL NUMBER

When ordering parts from your Authorized Case Dealer and in all contacts or correspondence with your dealer relative to the tractor always specify the Serial, Model and Engine Numbers of your tractor.

The Tractor Model and Serial Numbers are stamped on the number plate located on the instrument panel, Figure 3. The Engine, Model, Serial and Engine Specification Numbers are stamped on a plate fastened to the right or upper front side of the engine, Figure 4.

TRACTOR MODEL
AND SERIAL NUMBER

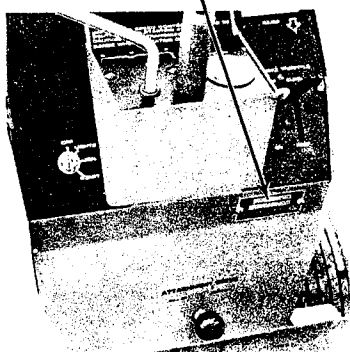

Figure 3.

ENGINE MODEL, SERIAL AND
SPECIFICATION NUMBER

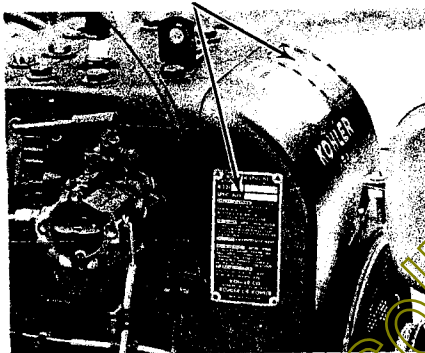

Figure 4.

NOTE

The terms "Right Hand" and "Left Hand" whenever used in this manual apply to the tractor when facing in the direction the tractor will move in forward operation.

For reference, fill in the Serial Number, Model Number and Engine Numbers of your tractor in the spaces provided below.

Tractor Model Number _____

Tractor Serial Number _____

Engine Model Number _____

Engine Serial Number _____

Engine Specification Number _____

gasoline engine

SPECIFICATIONS

General

444

Type	Kohler
Model	K321 AS
Cycle	4
Cylinders	1
Cylinder Bore	3-1/2 in.
Stroke	3-1/4 in.
Piston Displacement	31.27 cu. in.
Horsepower	14 HP
Compression Ratio	6 to 1
Full Load Speed	3500 RPM
No Load Speed	3600 RPM
Idle Speed	1000 RPM
Valve Clearance Cold (Intake)010 in.
Valve Clearance Cold (Exhaust)020 in.

Piston and Connecting Rod

Piston	Aluminum
Compression Rings	2
Oil Rings	1
Connecting Rod	Aluminum

Fuel System

Carburetor	1" SAE Flange
Filter Screen	In tank outlet fitting
Fuel Tank Capacity	8 Quarts

Ignition System

Type - Breakerless solid state with 10 amp flywheel alternator.
Ignition Timing is set at Kohler for life of engine.

Starter	12 volt Bendix drive
Spark Plug	Prestolite 14 L7 or equivalent
Thread	14 MM
Gap025"

Cooling System

Blower..... Forced air with baffles directing air
around finned cylinder and head area

general specifications

Hydraulic System

Reservoir-----Independent reservoir with built-in filter screen
Reservoir Capacity-----5 Quarts

Electrical System

Type of System-----12 Volt, Negative Ground
Battery-----Autolite LU7
Headlights-----12 Volt

Brake

Type-----Mechanical Contracting Band, with the drum shaft driven from transmission differential. Includes parking lock.

Transmission

Type-----Dual Range
Speed Ranges-----High and Low
Differential-----Automotive Type Bevel Gear
Oil Capacity-----3 Quarts

SPEED RANGE	FORWARD	REVERSE
Low	0 to 3.2 MPH	0 to 3.2 MPH
High	0 to 7.7 MPH	0 to 7.7 MPH

WHEELS AND TIRES

Tire Size	PLY	Type	PSI	
			Recommended	Max.
6.50-8	2	FRONT		
		High Flotation	8	14
8.00-16	2	REAR		
		High Flotation	8	14

Overall Measurements.

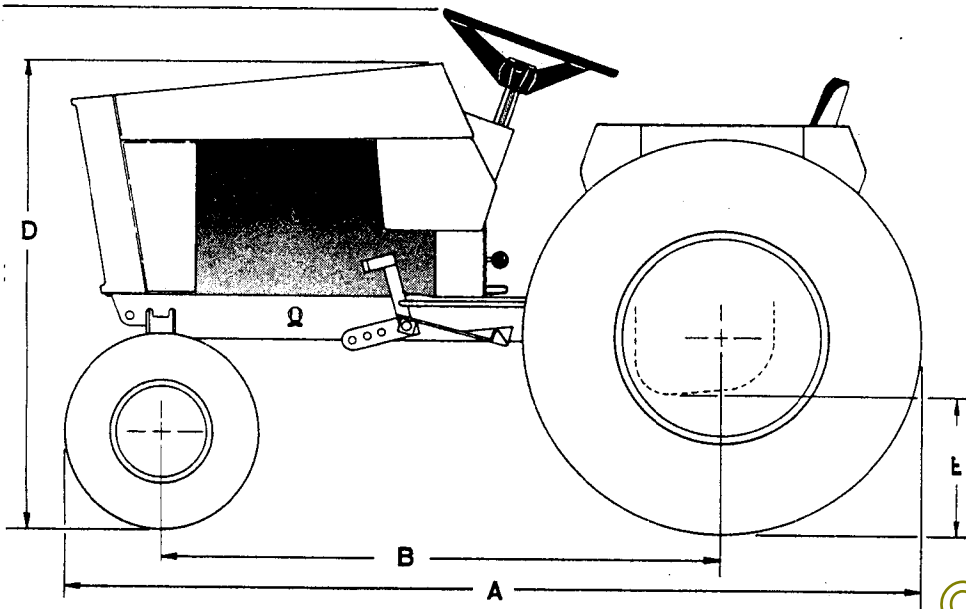

Figure 5.

A	Overall Length	79"
B	Wheel Base	46"
C	Overall Height	43-1/2"
D	Hood Height - Rear	38-1/2"
E	Minimum Ground Clearance at Gear Case	11"
	Rear Wheel Tread	31-1/2"
	Front Wheel Tread	33-1/2"
	Overall Width	41"
	Shipping Weight	750 lbs.

fuel specifications

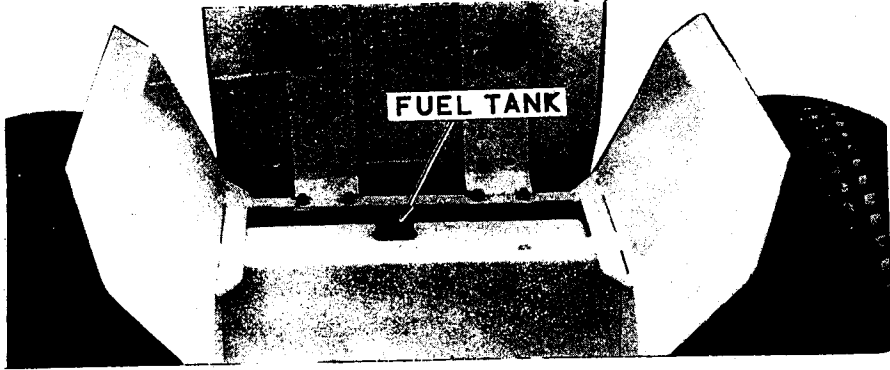

Figure 6.



NEVER FILL THE FUEL TANK WHEN THE ENGINE IS RUNNING OR WHEN NEAR AN OPEN FLAME. DO NOT SMOKE WHEN WORKING NEAR INFLAMMABLE FUELS.

FOR ADDED SAFETY THE FUEL TANK IS LOCATED UNDER THE HINGED SEAT AWAY FROM THE ELECTRICAL AND ENGINE COMPONENTS. SEE FIGURE 6.

GASOLINE

Kohler Gasoline Engines are designed to operate on REGULAR GRADE gasoline having a minimum research method rating of 90.7 Octane. This will give full power and economy together with long engine life and low maintenance cost.

The average Octane number ratings for regular grade gasoline (March 1967).

Motor Method -----	86.2 Octane Number
Research Method-----	94.2 Octane Number

These two Octane ratings are used to define the anti-knock quality of gasoline. It has become common practice in the Petroleum Industry to refer only to the RESEARCH METHOD RATING.

When only one Octane rating is given for gasoline and the rating method is not specified, it can be assumed to be the Research Method Rating.

FUEL CONDITIONER

The following "Fuel Conditioner" recommendations are made for areas troubled with gum and varnish in the fuel:

1. Obtain a "Case Lubra-Gas Conditioner" and use it as follows:
 - A. Add it to the fuel in the main storage container in proportions specified on the label.
 - B. Add a small quantity to the Tractor fuel tank daily.
 - C. Use the "Conditioner" periodically, or when any symptoms develop in the engine that indicate gum and varnish deposits in the Fuel System.

NOTE

Refer to the instructions furnished with the "Conditioner" as to the amount that should be used.



Figure 7

IMPORTANT

1. Buy Fuel in quantities that will be used up in 90 days or less.
2. Keep the main storage container sheltered so the fuel can be kept as cool as possible.



SAFETY PRECAUTIONS

1. BECOME THOROUGHLY FAMILIAR WITH ALL TRACTOR AND ATTACHMENT CONTROLS BEFORE OPERATING.
2. Before starting the engine, be sure all operating controls are in NEUTRAL. The "Safety Start" device prevents tractor from starting unless Speed Control Lever is in NEUTRAL.
3. Never operate any of the controls from any position but seated in the operator's seat.
4. Be extra careful when going down steep grades.
5. Drive at a speed slow enough to insure safety and complete control, especially over rough terrain.
6. Reduce ground speed when making a turn, going down hill or applying the brake.
7. Always operate the tractor in low range whenever on hills or steep inclines.
8. Never leave the tractor parked unattended on hills or steep inclines.
9. Change speed and direction of tractor with a smooth and gradual movement of the speed control arm. Avoid abrupt changes in speed or direction and avoid spinning wheels.
10. Never leave the engine running while it is unattended.
11. Never dismount from a Tractor when it is in motion.
12. Never permit persons other than the operator to ride on the Tractor.
13. Never stand between a Tractor and machine when hitching unless the Speed Control Lever is in NEUTRAL and the brake is engaged and locked.
14. DO NOT OIL, GREASE OR ADJUST A TRACTOR WHEN THE ENGINE IS RUNNING.
15. Never refuel a Tractor when the engine is running.
16. Do not smoke when refueling.
17. Never operate a Tractor in a closed shed or garage.
18. Do not wear loose fitting clothing which may catch in the moving parts.
19. To prevent highway accidents, use red warning flags in the daytime and red warning lamps at night.
20. Always have PTO lever disengaged and the brake pedal depressed and locked when parking or starting the Tractor.
21. REMEMBER, A CAREFUL OPERATOR IS ALWAYS THE BEST INSURANCE AGAINST AN ACCIDENT.

Lubrication

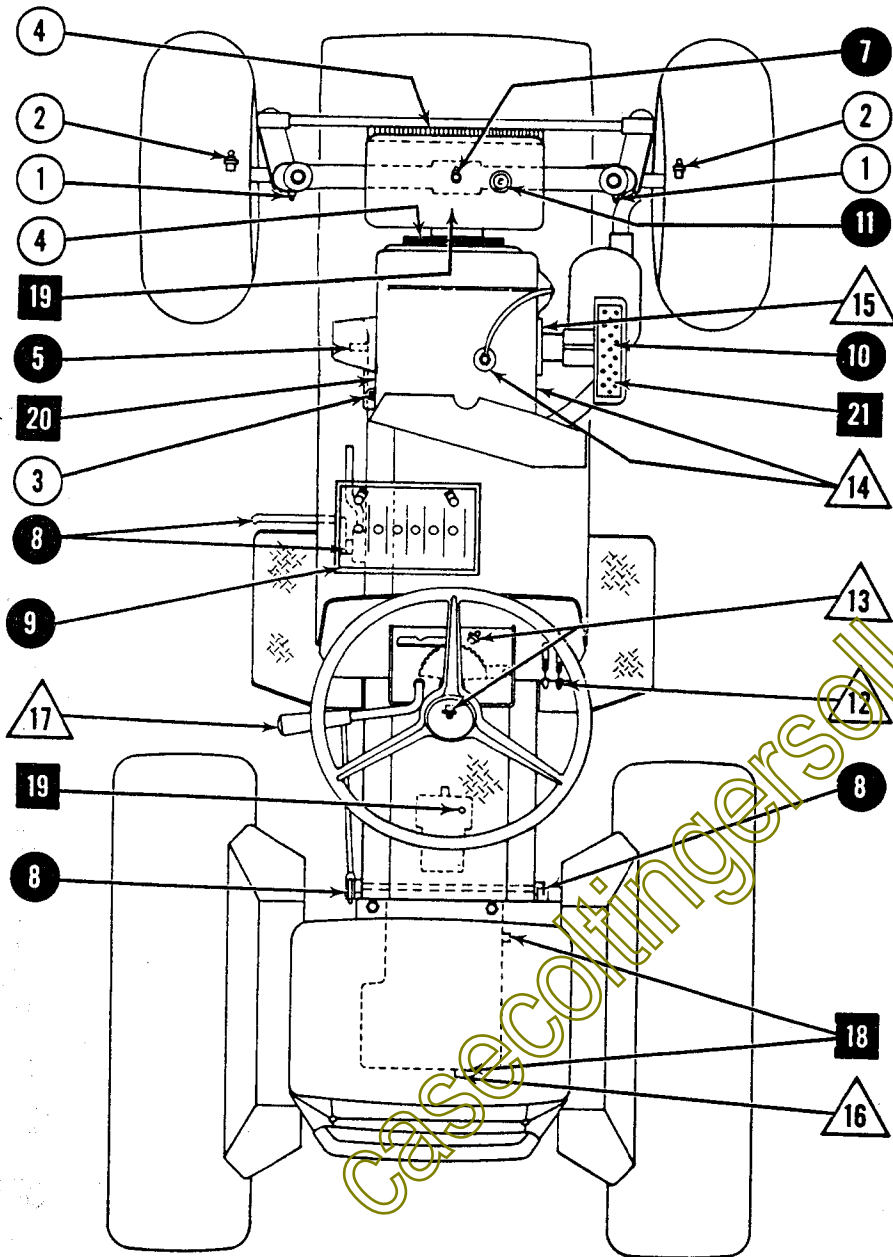

Figure 8

REF. NO.	SERVICE POINTS	NO. OF POINTS	GREASE	DRAIN	CHECK	CLEAN	CHANGE	OIL (Few Drops)	FREQUENCY
1	Front Spindles (king pins)	2	■						5 HOURS OR DAILY
2	Front Wheel Bearings	2	■						
3	Engine Oil *	1		■					25 HOURS OR WEEKLY
4	Blower Air Intake Screen	1		■					
5	Engine Oil +	2		■			■		50 HOURS OR MONTHLY
6	Air Leaks **	**							
7	Front Axle Pivot Pin	1	■						500 HOURS OR YEARLY
8	Implement Lever and Brake Linkage	6		■					
9	Battery	1		■					50 HOURS OR MONTHLY
10	Air Cleaner ***	1		■					
11	Hydraulic Oil +	2		■					500 HOURS OR YEARLY
12	Throttle and Choke Controls	2					■		
13	Steering Gear	3	■						50 HOURS OR MONTHLY
14	Spark Plug °	1		■					
15	Crankcase Breather ***	1			■				500 HOURS OR YEARLY
16	Transmission Oil +	1		■					
17	Speed Control Lever and Linkage	3					■		500 HOURS OR YEARLY
18	Transmission Oil +	2		■			■		
19	Hydraulic Oil +	1		■					500 HOURS OR YEARLY
20	Engine Cooling Fins ***	1			■				
21	Air Cleaner Element ***	1					■		500 HOURS OR YEARLY

*Keep oil level between marks on dipstick (capacity 3 pts.). See page 12 for engine lubrication recommendations.

**Be sure there are no leaks between gaskets, joints at carburetor, air cleaner and cylinder block.

***More often in dusty conditions.

°Clean and regap.

+Hydraulic System: Use SAE 5W-20 Motor Oil in winter (below 32° F.) and SAE 20W-40 Motor Oil in summer. Use only MS or DM Service Classification Oil that has passed Automotive Manufacturers Association (AMA) Test Sequences I, II, and III. Use SAE 20W-40 Motor Oil or No. 80 or 90 EP gear lubricant in transmission the year around.

The hydraulic system reservoir is located under the hood ahead of the engine. Maintain oil level between two and three inches from the top of the filler opening. The drain plug is located on the bottom side of the directional control valve.

Use number 1 gun grease (Lithium Base) for all pressure fittings (as many strokes as required).

ENGINE LUBRICATION

Selection of Lubricating Oil

It is extremely important that you select and use in your Case Tractor Engine a detergent type, high quality, SAE-MS or DM Service Classification Oil that has passed Automotive Manufacturers Association (AMA) Test Sequences I, II, and III.

Engine Oil SAE Viscosity Rating

SAE 30 or 20W-40----- Air Temperatures 30° F and Above

SAE 10W-30----- Air Temperatures 0° F to 30° F

SAE 5W-20 ----- Air Temperatures 0° F or Below

REGULAR OIL CHANGE

Drain and refill the crankcase at least every 25 hours of operation.

If possible, run engine just prior to changing oil--the oil will flow more freely and carry away a greater amount of contaminant when hot.

If the engine service is severe-(frequent stopping and starting, high or low operating temperature)-the crankcase should be drained more often to prevent the formation of sludge or harmful deposits in the engine.

CRANKCASE OIL CHANGE

IMPORTANT

1. When just the crankcase is drained, always refill with 3 measured pints of oil. Do not refill using the dipstick as a guide.
2. Operate the engine for a few minutes; then check the oil level with the dipstick.

Be sure to allow sufficient time for the oil to run down off the engine parts.

3. By following the above procedure, you will prevent overfilling or underfilling the crankcase, either of which can be detrimental to the engine service life and will give you false oil consumption records.

operating instructions

RUN-IN PROCEDURE

Your new tractor should be subjected to a run-in period before it is operated at full load. Drive the tractor for approximately an hour to get the feel of operation. Actuate the speed control lever through its full range during the run-in period.

PRE-STARTING CHECK LIST

Before starting your new Case Tractor for the first time and before each operating period thereafter, check the following.

1. MAKE SURE EVERYONE RESPONSIBLE FOR THE TRACTOR'S OPERATION AND MAINTENANCE UNDERSTANDS THE IMPORTANCE OF CLEAN FUEL, OILS, CONTAINERS AND FUNNELS.
2. Check that all lubricating fittings are serviced as directed in the Lubrication Chart.
3. Check engine and hydraulic reservoir oil levels and add as necessary.
4. Be sure that air cleaner, heat exchanger fins, and blower air intake screen on engine are free of obstructions and excessive dirt.
5. Check that tractor fuel tank is filled with clean fuel that meets requirements listed under Fuel Specifications. Always wipe fuel tank cap clean before removing it. Be sure vent hole in fuel tank cap is open.
6. This tractor is equipped with a "safety start" feature. The Speed Control Lever must be in NEUTRAL to start the engine.

OPERATING CONTROLS AND INSTRUMENTS

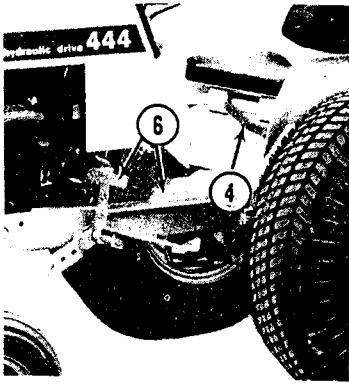

Figure 9.

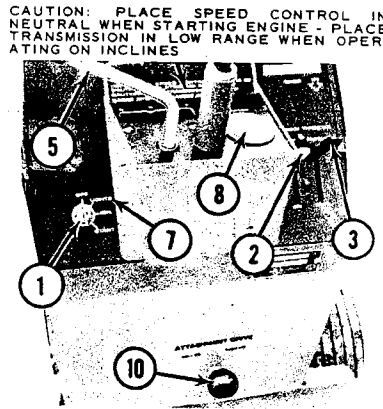

Figure 10.



1. **IGNITION KEY AND STARTER SWITCH** - Turn the key to the right (Start) position to start the engine. When shutting the engine off, turn the key to the full "Off" (upright position).

DO NOT START THE ENGINE WITH THE PTO ENGAGED.

2. **CHOKE** - To start a cold engine, push choke lever down. Push lever up when engine is started.
3. **THROTTLE** - When the throttle lever is all the way up, the engine should be idling. To increase the engine RPM, push the lever downward until the desired throttle setting is obtained.
4. **HIGH - LOW RANGE SHIFT LEVER** - When shifting into Low or High Range, make certain the locking pin welded into the rear side of the lever is placed into the upper or lower locking hole in the seat support. Likewise, when shifting to neutral, the pin must be placed in the center hole. Gear damage can result if the tractor is operated while the shift lever locking pin is not in one of the three holes in the seat support.
5. **SPEED "CUSHION" CONTROL LEVER** - This single lever provides effortless and smooth "finger-tip Cushion Control" of speed and direction. Move the lever forward as desired to obtain either full speed ahead or to "creep" through heavy grass or deep snow. For reverse, simply pull the lever towards the rear. Full engine power is always available to the attachment regardless of the tractor travel speed.

NOTE The tractor is equipped with "Safety-Start" and cannot be started unless the Speed Control Lever is in the neutral position.

CAUTION The Speed Control Lever automatically returns to neutral when the brake is applied. Do not attempt to manually hold this lever in forward or reverse when applying the brake since damage to the mechanism could result.

An exclusive "over-ride" feature permits the speed control lever to be moved into forward or reverse after braking and while your foot is still on the brake. To release the return-to-neutral mechanism with the brake engaged, first push the speed control lever down until the linkage disengages, then move the lever into forward or reverse. Slowly release the brake pedal when power is obtained at the rear wheels.

6. BRAKING AND PARKING - The speed control lever (Ref. 5) can also be used as a brake by returning it to the neutral position. On a level surface the tractor will come to a normal stop by returning the Speed Control Lever to neutral. If on a hill or if a fast stop is necessary, depress the brake pedal. When getting off the tractor, always depress and lock the brake to prevent tractor movement.



Operate the tractor in low range on hills or inclines. Do not leave tractor parked unattended on hills unless the wheels are adequately blocked. Always lock the brake and turn off the engine when parking and leaving the tractor.

NOTE The speed control lever can be used in lieu of the brake pedal to control the tractor ground speed on hillside operation. Remember, however, that if the brake is applied the speed control lever will be automatically returned to neutral.

7. HEADLIGHTS - The headlights are turned on when the ignition key is turned to the "Light" position after the engine is started. Do not operate the headlights unless the engine is running.
8. AMMETER - When the engine is started and running above idle speed, the ammeter should show a charging rate and gradually fall back as the battery becomes charged.

9. **POWER LIFT CONTROL LEVER**.- The power lift lever is used to raise or lower the implement and also to hold the implement at any given level. The wing nut at the base can be turned in or out to adjust the minimum operating height of an attachment. The lettered decal (A through F) provides a means of visual reference to the operating height of an attachment once the initial installation and desired setting is established. Pull back on the power lift lever to raise the attachment. To lower the attachment push the lever ahead. The control valve has a centering spring which returns the lever to neutral from either the "raise" or "lower" position. The speed at which the attachment is raised or lowered can be controlled by the amount of back or forward movement on the control lever. You may find it helpful, when very close control of the attachment is necessary, to use the steering wheel or the rear of the hood as a support for your hand when moving the lever. When transporting attachments, hold back on the control lever until the upward movement of the attachment stops.
10. **PTO CONTROL** - Pull out on the PTO clutch control to engage the attachment drive. To disengage the drive, simply push it back in. Be sure the PTO lever is in the off position when parking or starting the tractor.
11. **DOWN-PRESSURE PIN** - This pin must be set in the outer float position for mowing, snowcasting and tilling where the attachment must follow the ground contour. Damage to the attachment and hydraulic lift mechanism as well as poor work performance can result if these attachments are operated with this pin in the "down pressure" position.

The pin may be placed in the inner "down pressure" position for some dozing and blade operations but is not recommended for snow dozing.

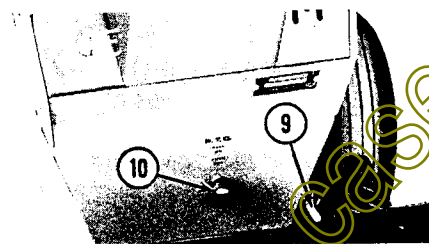

Figure 11.

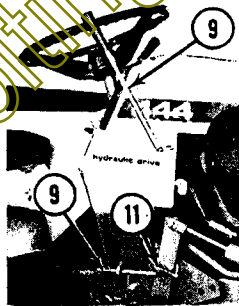

Figure 12.

STARTING PROCEDURE

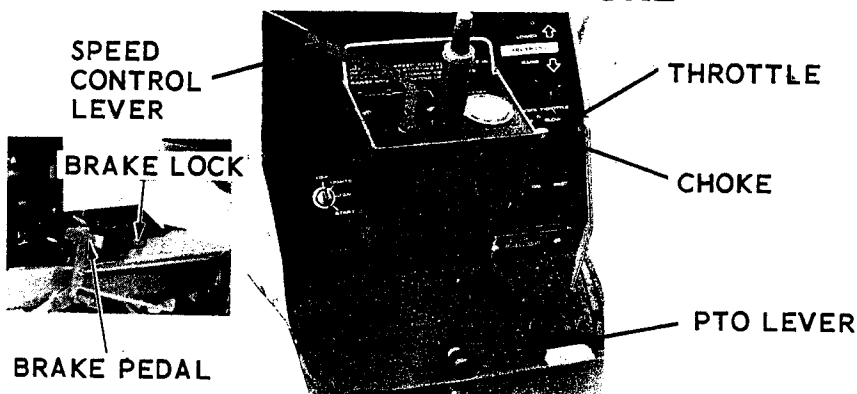

Figure 13.

1. Place the speed control lever in the NEUTRAL position. The "Safety-Start" feature prevents the engine from starting unless the speed control lever is in neutral.
2. Place the PTO lever in IN position.
3. Engage and lock the brake pedal.
4. Close the choke by pushing the control lever down. More or less choking may be necessary due to variations in temperature, grade of fuel, etc. Little or no choking will be needed when engine is warm. In cold weather, it is advisable to position the throttle lever about one-third open.
5. Turn the starter key all the way to the right to start engine.
6. After the engine starts and runs, push the choke control lever all the way up. Always allow engine to warm up before applying a load. Release the brake pedal slowly after engine starts.

CAUTION

DO NOT USE THE STARTER LONGER THAN 30 SECONDS WITHOUT INTERRUPTION. WAIT AT LEAST 3 MINUTES SO THE STARTER CAN COOL DOWN BETWEEN PERIODS OF USAGE.

STOPPING THE ENGINE

1. An engine that has been working under load should idle for a few minutes so the engine parts can cool evenly before it is shut off.
2. Turn starter key to "OFF" or upright position.

preventive maintenance

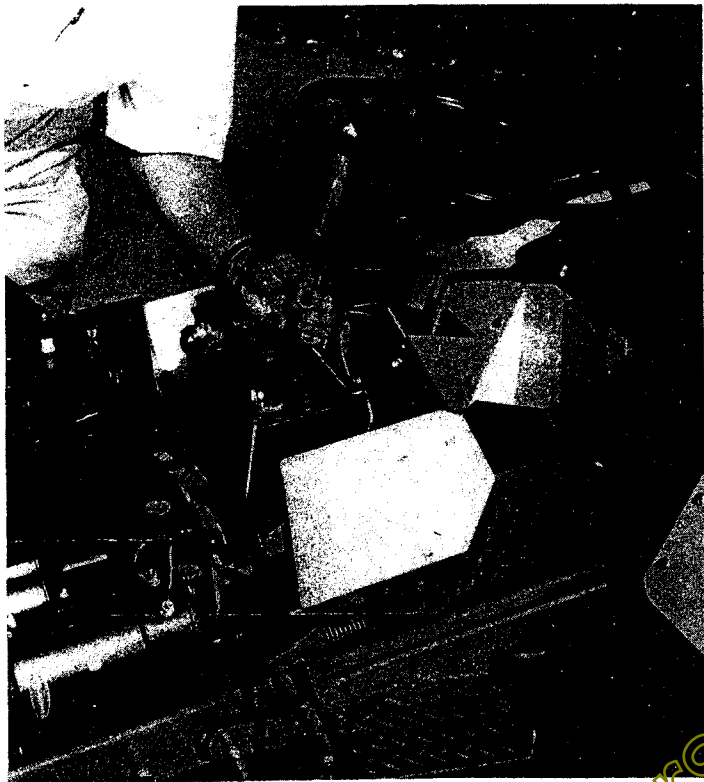

PREVENTIVE MAINTENANCE IS IMPORTANT TO YOU!

AS THE OWNER OF A CASE TRACTOR, YOU POSSESS A MACHINE THAT IS MADE TO THE HIGHEST STANDARDS POSSIBLE.

PREVENTIVE MAINTENANCE BY YOU OR YOUR OPERATOR IS THE EASIEST AND MOST ECONOMICAL MEANS OF ASSURING MANY SATISFACTORY PRODUCTIVE HOURS OF OPERATION.

The preceding sections of this operator's manual have dealt with instructions necessary for daily operation of your Tractor. The following subjects present detailed instructions concerning the care and adjustment of the Tractor.

BRAKE ADJUSTMENT

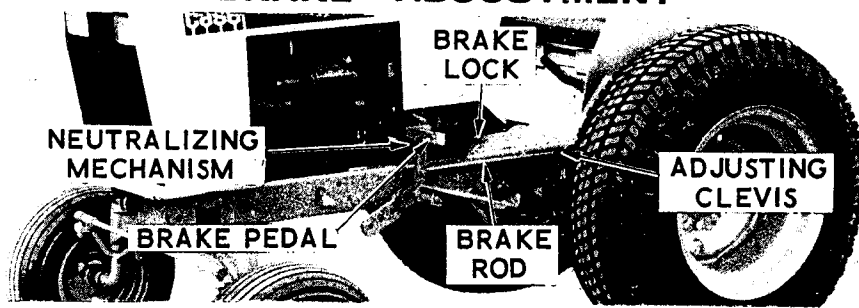

Figure 14

The brake is properly adjusted when depressing the pedal brings the tractor to a prompt stop and when there is sufficient pedal travel to allow the "neutralizing mechanism" to return the speed control lever from both the forward and reverse travel positions.

Turn the "adjusting clevis" further on the brake rod to decrease pedal travel. To increase pedal travel, turn the "adjusting clevis" further off the brake rod. Be careful not to overadjust the clevis in either direction since if the pedal travel is too limited the speed control lever will not return to neutral. Excessive pedal travel will cause the brakes to be less effective.

Adjust the clevis on the "brake rod" to obtain the proper amount of pedal travel. Replace the brake band before the lining becomes worn through at any area to prevent damaging the drum.

AIR CLEANER

Remove and clean element after each 25 hours or weekly. Install new element every 500 hours or yearly or when loss of power is noticeable.

To clean the element, remove the wing nut, washer, cleaner cover and remove the element. Tap element lightly on a flat surface to cause the loose dirt to fall off. Handle the paper element with care to avoid damage to element.

Do not wash, use compressed air or solvent to clean element.

Replace the element with a new one if dirt does not drop off easily or if it is bent, crushed or damaged. When replacing the element, be sure it fits snugly around the inside edge of the air cleaner base. Then replace the cover, washer and tighten the wing nut finger tight.

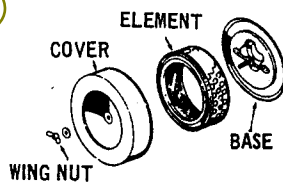

Figure 15

CARBURETOR

The carburetor has three simple adjustments:

1. High Speed Mixture Adjustment
2. Idle Mixture Adjustment
3. Idle Speed Adjustment

High Speed Adjustment

With engine running and throttle fully open, adjust the high speed screw, Figure 16, by turning the adjusting screw clockwise (in) until the engine misfires or falls off; then turn the adjusting screw counterclockwise (out) until the engine runs smoothly, approximately two turns.

Place the tractor under load and observe how the engine handles the load. Loss of power, tendency to stall, or excessive backfiring all indicate a lean mixture. Turn adjusting screw counterclockwise not more than 1/8 of a turn and again try the engine performance. When the high speed screw is correctly adjusted, it will not be necessary to reset the carburetor unless load conditions or fuel quality have been radically changed.

Operating an engine on too lean a mixture causes loss of power and high exhaust heat.

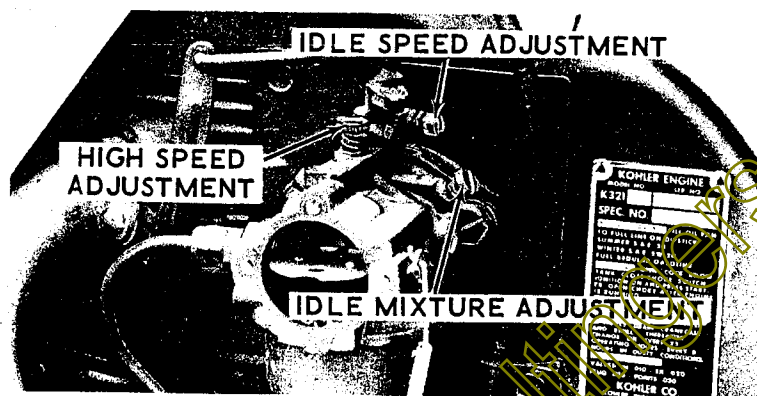

Figure 16

Idling Speed and Idling Mixture Adjustment

Turn the idle mixture screw, Figure 16, counterclockwise approximately 1-1/4 turns from the closed position. Place the throttle in 1/2 open position and start engine. With the throttle all the way up, turn the idle speed adjusting screw, Figure 16, until 1000 RPM is obtained. The idle mixture screw can be adjusted in or out until the engine runs smoothly while maintaining 1000 RPM with the idle speed adjusting screw.

Spark Plug

The type spark plug provided in your engine is listed as medium in the spark plug heat range chart - Prestolite 14 L7 or equivalent.

Shank Length -----7/16"
Thread Size -----14 MM
Gap Setting -----.025 Inch

NOTE

It is possible that under unusual conditions, "colder" type spark plug may be required. Consult your Authorized Case Dealer regarding the proper type spark plug to use for your particular condition.

The spark plug plays a very important part in the power, fuel economy and general performance of your engine. The outside of the plug should be cleaned frequently to prevent shorting of the plug.

The spark plug should be removed, checked, cleaned and gapped at the end of every 100 hours of operation.

Removing

It is important to select the exact size spark plug wrench. The wrong size or type wrench may cause distortion and insulator breakage. Always use a spark plug wrench or a thin wall deep socket wrench of the recommended size.

Thoroughly clean the spark plug, including the threads. Check the electrode gaps using a .025 inch gauge. A very slight drag should be felt when the gauge wire passes between the electrodes.

Reset the gaps by bending the side electrode only. Never bend the center electrode.

Installing

Install the spark plug, with a new gasket, in the engine and seat the plug on the gasket, finger tight. Tighten the plug about 3/4 of a turn after the plug is seated firmly on its gasket. If a torque wrench is available, tighten the plug to 27 foot-pounds. This will assure proper seating and sealing of the spark plug.

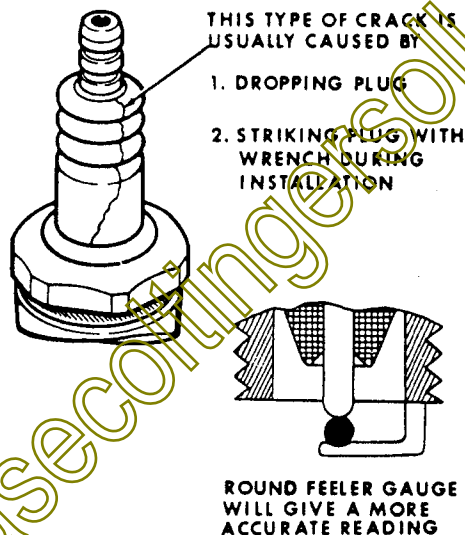

Figure 17

Steering Adjustment

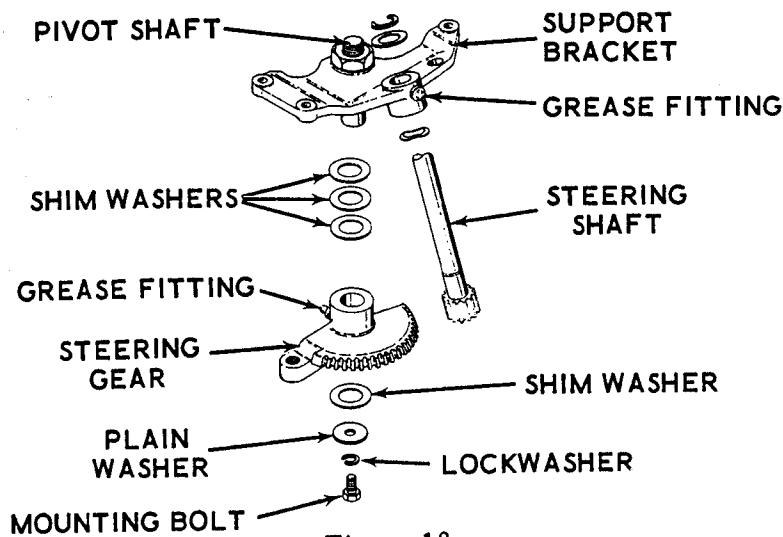

Figure 18

The tractor is designed with two or more shim washers between the steering gear and support bracket as illustrated in Figure 18. As the gear teeth wear in, additional steering wheel free play may occur. If the free play becomes excessive, one (more if necessary) of the shims can be relocated to the bottom side of the steering gear.

Disconnect the drag link from the steering gear. Remove the mounting bolt, lockwasher and plain washer (shims also if present) from the base of the pivot shaft. Slip the steering gear and one of the shim washers off the pivot shaft. Place the gear back on the pivot shaft and secure with the original mounting bolt, lockwasher, plain washer, shim(s) plus the shim removed from the upper side. The total number of shim washers must remain the same.

CAUTION Make certain that some free play remains since a tight fit with no clearance between the two gears may cause binding.

NOTE Always coat all gear teeth with grease each time the two steering fittings are lubricated or at least each 50 hours operation.

CAUTION Excessive steering wheel free play may not require gear adjustment as covered above. First check to make certain all ball joints on the drag link and tie rods are tight.

Toe-in Adjustment

1. Locate the tractor on a hard level surface preferably concrete. Place front wheels in a straight ahead position.
2. Make sure the front tire pressures are equal.
3. The front tires should show a mold part-line which coincides with the centerline of the tire. If the centerline of the tire is not readily visible then the wheel can be raised off the ground, spun and marked at the approximate centerline location.
4. Measure the distance between the tire center lines or the chalk marks.

THE DISTANCE BETWEEN MEASUREMENT A MUST BE $1/8$ TO $3/8$ -INCH LESS THAN MEASUREMENT B. BOTH MEASUREMENTS - FRONT AND REAR MUST BE TAKEN AT THE SAME HEIGHT ABOVE THE FLOOR.

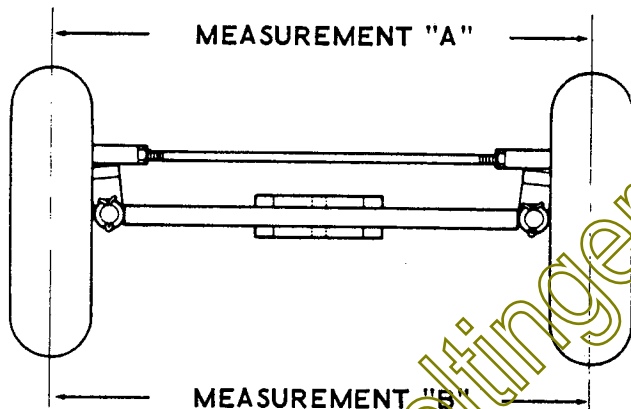

Figure 19.

1. Loosen both tie rod joints.
2. Turn both joints on or off the tie rod an equal amount. Retighten the joints when correct toe-in is obtained. Turning the joints on the tie rod increases the toe-in. Turning the joints off the tie rod decreases the toe-in.

ELECTRICAL SYSTEM

Headlights

To install a new Case 12 volt replacement headlight bulb, loosen the Retainer Screws and with the hood raised turn the Retainers off the Receptacle. Carefully lift the Receptacle off the Lens and place between the hood and hydraulic system reservoir on the side opposite from where it was removed.

Remove the old bulb by pushing inward and turning it counter-clockwise. Install the new Case bulb and replace the receptacle making certain one gasket is located between the lens and grille and the other is properly seated between the lens and receptacle.

The new bulb will not light unless the receptacle is re-installed or manually grounded to a metal part on the tractor.

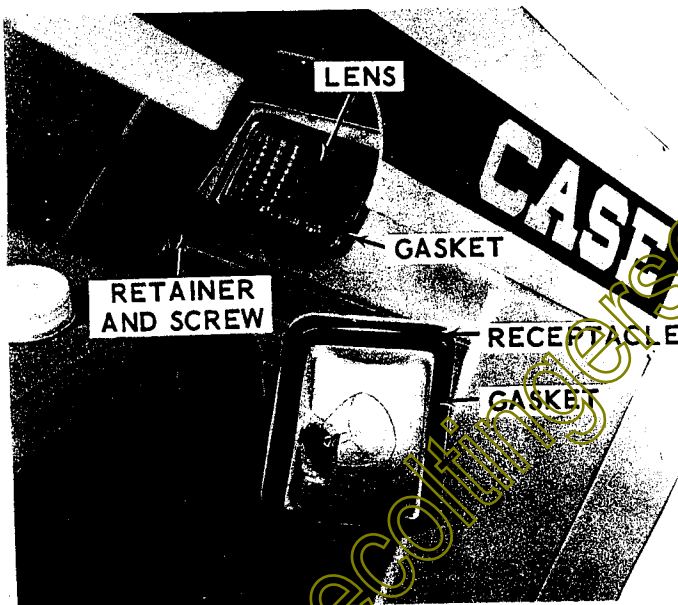

Figure 20

After installing the new unit, make sure all the connections are tight.

STORAGE BATTERY



When working around a storage battery, remember all of its exposed metal parts are "live". Never lay a metal object across the terminals as spark or short circuit may result. Sparks, lighted matches and exposed flames must be kept away from the battery due to the presence of explosive gas in the battery.

The liquid in the battery is acid. Use care not to spill it on hands or clothing.

Rules for Battery Care

1. Add pure or distilled water, as needed, to keep the separators covered. Check every 25 hours or weekly depending on air temperature. Normal water consumption would be approximately 1 ounce every 25 hours of operation. If it is greater, either the case is leaking or the regulator is overcharging and must be adjusted.
2. Keep the battery in a healthy state of charge as shown by hydrometer readings.
3. Make sure the battery is securely fastened in position. Cable leading from the battery should not touch cell connectors or lay on the battery container.
4. Keep the battery clean and dry.

If a battery will not hold a charge, replace it with a new one meeting the specifications as listed in the specification section.

NOTE

The full charge gravity reading will usually be specified on the battery. A battery having a reading of 1.175 will freeze at approximately 0° Fahrenheit temperature.

Adding Water

Unless the tap water in your area is "approved" (water free of scale-forming minerals), always add distilled water to the battery.

When water is added during freezing weather, the battery must receive a charge immediately to mix the water and electrolyte. If it is not mixed, the water will remain at the top and freeze.

Check the liquid level in each cell weekly by removing the vent plugs. Add water before the tops of the separators become exposed. DO NOT OVERFILL.

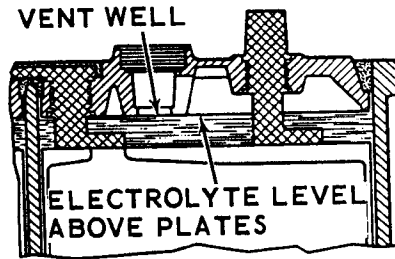

Figure 15

Vent Plugs

Always keep the vent plugs in place and tight. Be sure the vent holes are free of dirt to prevent gas pressure in cells from breaking the sealing or the container.

Cable Terminals and Battery Posts

The battery terminals must be kept clean and tight. A good method of cleaning terminals is to remove all excess corrosion with a wire brush, then wash with a weak baking soda solution or ammonia. After cleaning, a thin coating of vaseline or light cup grease will retard further corrosion.

Idle Battery

When the Tractor is not in active use, the battery will require a charge at sufficient intervals to keep the hydrometer reading at or above 1.250. An idle storage battery will slowly discharge.

WIRING DIAGRAM FOR CASE MODEL 444 COMPACT TRACTORS

SWITCH INSTALLATION POSITION

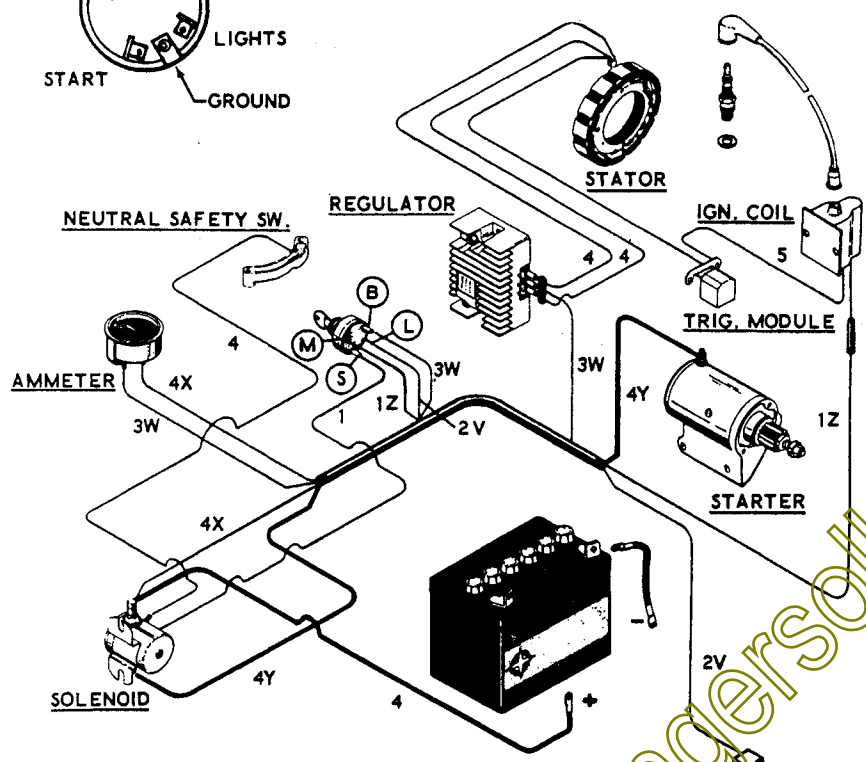
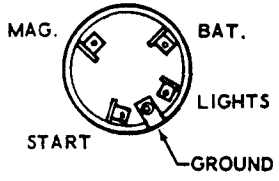

Wire Color Code

- 1. Red
- 2. Green
- 3. Blue
- 4. Black
- 5. White

NOTE:

Numbers indicate wire color code. Letters indicate wire routing.

casecollectingersonline.com

AVAILABLE ATTACHMENTS

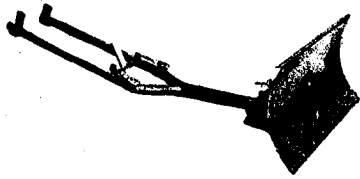

DOZER AND SNOW BLADE
WITH SPRING TRIP



SLEEVE HITCH
(3-POINT HITCH ALSO
AVAILABLE)

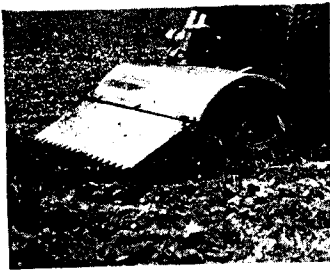

HYDRA-TILLER

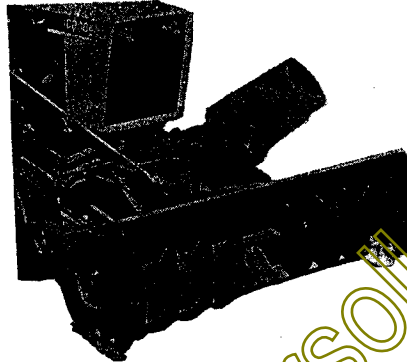

SNOWCASTER

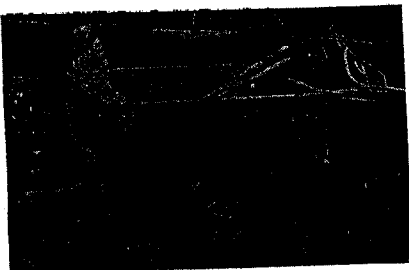

1000 POUND CAPACITY
DUMP CART



THREE SPINDLE ROTARY MOWER

MANY OTHER USEFUL ATTACHMENTS ARE
AVAILABLE THROUGH YOUR J. I. CASE DEALER

AVAILABLE ATTACHMENTS

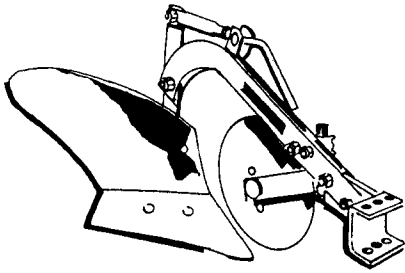

PLOW

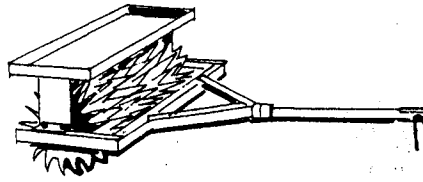

SPIKER AERATOR

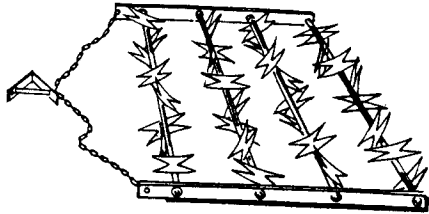

SPIKE HARROW

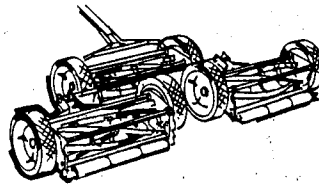

REEL MOWER

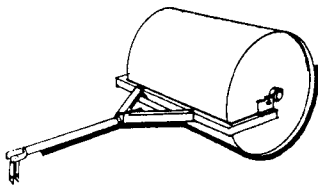

ROLLER

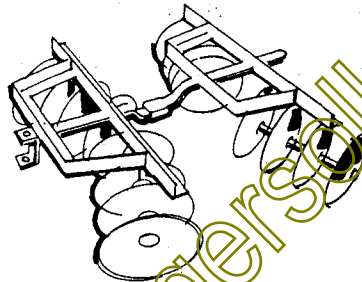

DISC HARROW

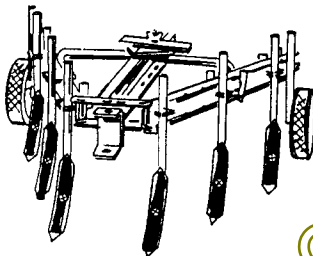

SPRING HARROW

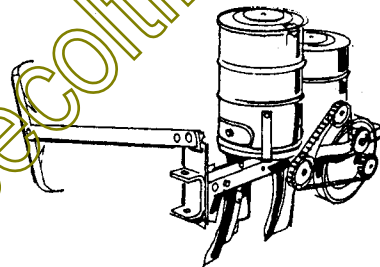

PLANTER-FERTILIZER

MANY OTHER USEFUL ATTACHMENTS ARE AVAILABLE THROUGH YOUR J. I. CASE DEALER.

TABLE OF CONTENTS

SERIAL NUMBER	3
ENGINE SPECIFICATIONS	4
GENERAL SPECIFICATIONS	5
Hydraulic System	5
Electrical System	5
Brake	5
Transmission	5
Wheels and Tires	5
Overall Measurements	6
FUEL SPECIFICATIONS	7
Fuel Conditioner	8
SAFETY PRECAUTIONS	9
LUBRICATION	10
Lubrication Chart	10-11
Engine Lubrication	12
OPERATING INSTRUCTIONS	13
Run-In Procedure	13
Pre-Starting Check List	13
Operating Controls and Instruments	14 thru 16
Starting Procedure	17
PREVENTIVE MAINTENANCE	18
Brake Adjustment	19
Air Cleaner	19
Carburetor Adjustments	20
Spark Plugs	21
Steering Adjustments	22
Toe-In Adjustments	23
Electrical System	24
Storage Battery	25-26
Wiring Diagram	27
ATTACHMENTS	28-29

casecoltingersoll.com

Printed in U.S.A.