

# Ingersoll

THREE POINT HITCH  
MODEL HH34, HH60  
F27 SLEEVE ADAPTER  
Operator's Manual 8-56391

[casecoltingersoll.com](http://casecoltingersoll.com)

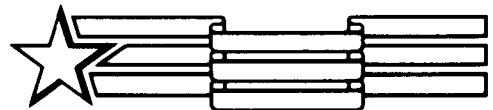

QUALITY IN THE AMERICAN TRADITION

Ingersoll Equipment Co., Inc.

Winneconne, Wisconsin 54986-9576



This Safety Alert Symbol Indicates Important Safety Messages In This Manual. When You See This Symbol Carefully Read The Message That Follows and Be Alert To The Possibility Of Personal Injury Or Death

IF THIS MACHINE IS USED BY AN EMPLOYEE OR IS LOANED OR RENTED, MAKE ABSOLUTELY CERTAIN THAT THE OPERATOR(S), PRIOR TO OPERATING:

1. IS INSTRUCTED IN SAFE AND PROPER USE.
2. REVIEWS AND UNDERSTANDS THE MANUAL(S) PERTAINING TO THE MACHINE.

751253



# WARNING

## BEFORE STARTING ENGINE

STUDY OPERATOR'S MANUAL SAFETY MESSAGES  
READ ALL SAFETY SIGNS ON MACHINE  
CLEAR THE AREA OF OTHER PERSONS

## LEARN & PRACTICE SAFE USE OF CONTROLS BEFORE OPERATING

IT IS YOUR RESPONSIBILITY TO UNDERSTAND AND FOLLOW MANUFACTURER'S INSTRUCTIONS ON MACHINE OPERATION, SERVICE, AND TO OBSERVE PERTINENT LAWS AND REGULATIONS. OPERATOR AND SERVICE MANUALS MAY BE OBTAINED FROM YOUR EQUIPMENT DEALER.

## SAFETY MESSAGES



The safety messages contained in this manual are to be used together with the safety messages appearing in the tractor operator's manual. Be sure to review both carefully before operating the tractor-attachment combination.

**CAUTION:** Be sure to apply sufficient front counterweight to tractor before operating with rear mounted attachment. Driving tractor with insufficient front counterweight could result in front end tipup and personal injury.

Apply at least 110 lbs. (50 kg) for 3000 series tractors and 140 lbs. (64 kg) for 4000 series tractors.

Heavy attachments and attachments that extend far behind tractor may require more counterweighting. Operate tractor with extreme care and at slow speed to determine if more than the minimum amount of counterweight listed above is required. Add counterweight as necessary to achieve front end stability.

**DO NOT EXCEED HITCH LIFT CAPACITY.**

Remember, a careful operator is always the best insurance against an accident. Always give complete and undivided attention to the job at hand.

**CAUTION:** Only operate controls while seated in the operator's seat.



**CAUTION:** Always lower any rear or front mounted implement to the ground when leaving the tractor unattended.



**CAUTION:** Place the transmission in neutral, set the parking brake and stop the engine before standing between the tractor and attachment when hitching.



**CAUTION:** Hydraulic systems are highly pressurized. Escaping hydraulic oil, even an invisible pinhole leak, can penetrate body tissues causing serious injury. Use a piece of wood or cardboard when looking for leaks - never use the hands or other parts of the body.

Relieve hydraulic pressure before disconnecting circuits. When reassembling, make absolutely certain that all connections are tight.

If injured by hydraulic oil escaping under pressure, see a doctor immediately. Serious complications may arise if medical attention is not given at once.

**IMPORTANT:** Always install new decals whenever the old decals are destroyed, lost, painted over or illegible. When individual parts are replaced that have decals attached, be sure to install a new decal with the new part. Decals are available from your dealer.

## INTRODUCTION

This manual contains recommended operating procedures, safety messages, assembly and mounting instructions. Read this manual carefully before operating your hydraulic 3-Point hitch and sleeve adaptor.

The 3-Point hitch is designed in accordance with ASAE Specification, Category "O" and will accommodate all attachments manufactured to this standard.

The definitions "Right, Left, Front and Rear" as used throughout this manual relate to the tractor and hitch as the operator is seated facing forward in the normal operating position on the tractor.

**NOTE:** Ingersoll Equipment Co., Inc. reserves the right to make improvements in design or changes in specifications at any time without incurring any obligation to install them on units previously sold.

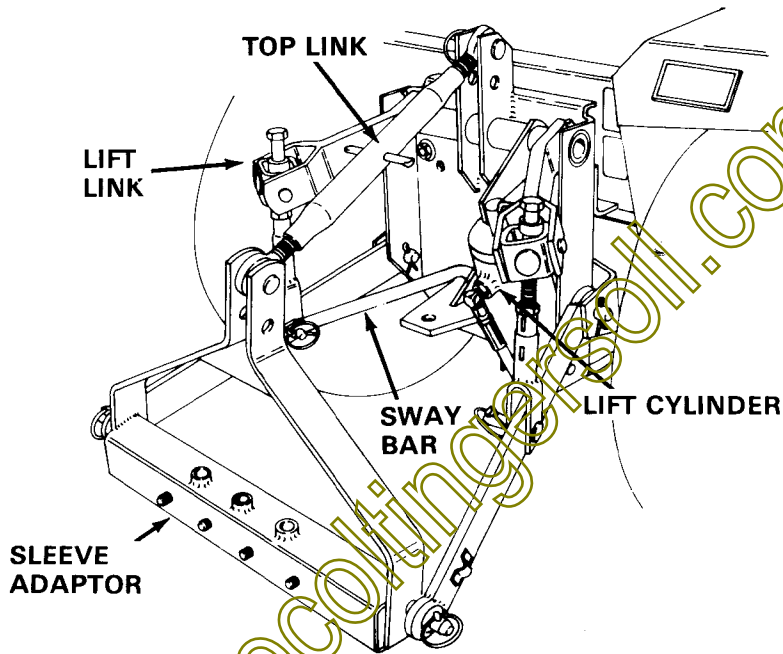

FIGURE 1

## HITCH APPLICATION CHART

HITCH MODEL	TRACTOR MODEL
HH34	3010, 3012, 3014, 3016, 3018 4014, 4016, 4018, 4020, ALL
HH60 or HH34	6018 ALL
F27	HH34, HH60, H26, J26 and LT26 ALL

NOTE: Previous model HH60 hitch is replaced by HH34.

# OPERATING CONTROLS AND ADJUSTMENTS

## 1. Hydraulic Lift

The 3-Point hitch is connected to the tractor hydraulic lift circuit and is equipped with a double-acting hydraulic cylinder.

**RAISE** - Pull the hydraulic lift lever rearward to raise the hitch.

**LOWER** - Push the hydraulic lift lever partway forward to lower the hitch. Down pressure is applied when the hitch is in its lowest position (cylinder fully retracted).

The hydraulic lift centering spring returns the valve to neutral after raising or lowering the hitch.

**FLOAT** - Push the hydraulic lift lever fully forward for the float position. The lever will be held in float by a detent and must be manually returned to neutral.

The float position allows the attachment to follow the ground and is recommended for tilling or plowing.

See your tractor operator's manual for correct use of the tractor controls.



**CAUTION: Only operate controls while seated in the operator's seat.**

## 2. Lift Links

The lift links are threaded and adjustable. Use them to level a mounted attachment or to compensate for the right wheels being in the furrow when plowing.

## 3. Top Link

The top link is threaded and is used to set the fore-aft pitch of the attachment. Two mounting holes for the top link are provided on the hitch frame to aid in setting fore-aft pitch adjustment.

## 4. Sway Bar

The sway bar must be kept anchored to the tow bracket to prevent interference with rear wheels.

## F-27 SLEEVE ADAPTOR

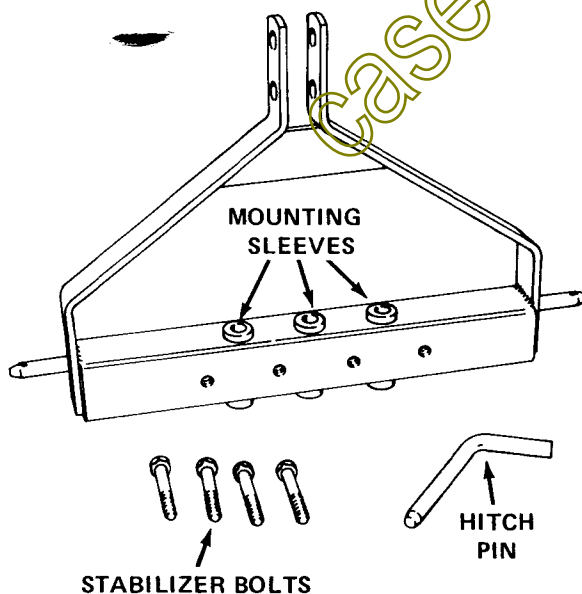

FIGURE 2



**CAUTION: Always lower any rear or front mounted implement to the ground when leaving the tractor unattended.**

The Model F-27 sleeve adaptor converts the 3-Point Hitch to accept sleeve type mounted implements.

1. Four implement stabilizing bolts (Figure 2) are furnished with the sleeve adaptor for use at the four threaded holes. Use these bolts to prevent excessive movement of the attachment. A plow should not be stabilized at this point.
2. There are three mounting sleeves (Figure 2) on the sleeve adaptor to permit centering or offsetting implements. When mounting a plow, be careful to select the mounting position which will allow the share to cut cleanly to the edge of the previous furrow and to the inside of the right rear wheel.

## TIRE CHAINS, WHEEL WEIGHTS AND FRONT END WEIGHTS

The use of tire chains and wheel weights is recommended with the hitch. The extra traction resulting gives the tractor operator increased maneuverability. Front end weights or front weight box is required for stability.

**NOTE:** Front end weight may be added to loader bucket if required.

**CAUTION:** Be sure to apply sufficient front counterweight to tractor before operating with rear mounted attachment. Driving tractor with insufficient front counterweight could result in front end tipup and personal injury.

Apply at least 110 lbs. (50 kg) for 3000 series tractors and 140 lbs. (64 kg) for 4000 series tractors.

Heavy attachments and attachments that extend far behind tractor may require more counterweighting. Operate tractor with extreme care and at slow speed to determine if more than the minimum amount of counterweight listed above is required. Add counterweight as necessary to achieve front end stability.

**DO NOT EXCEED HITCH LIFT CAPACITY.**



**CAUTION:** Place the transmission in neutral, set the parking brake and stop the engine before standing between the tractor and attachment when hitching.



Remember, a careful operator is always the best insurance against an accident. Always give complete and undivided attention to the job at hand.

### MAINTENANCE

1. Grease two fittings on hitch rockshaft daily.
2. Apply oil to pivot pins and attachment mounting pins daily.
3. Do not oil ball joints as this may cause abrasive foreign material to lodge between the ball and retainer.
4. Check for tightness. After first two hours of operation, tighten all bolts which secure hitch to the tractor.
5. A certain amount of oil will normally accumulate at the rod end cap of the lift cylinder during operation. This provides lubrication for the moving parts. There is no requirement for service or repair unless leakage is excessive.
6. Maintain tractor as described in Tractor Operator's Manual.

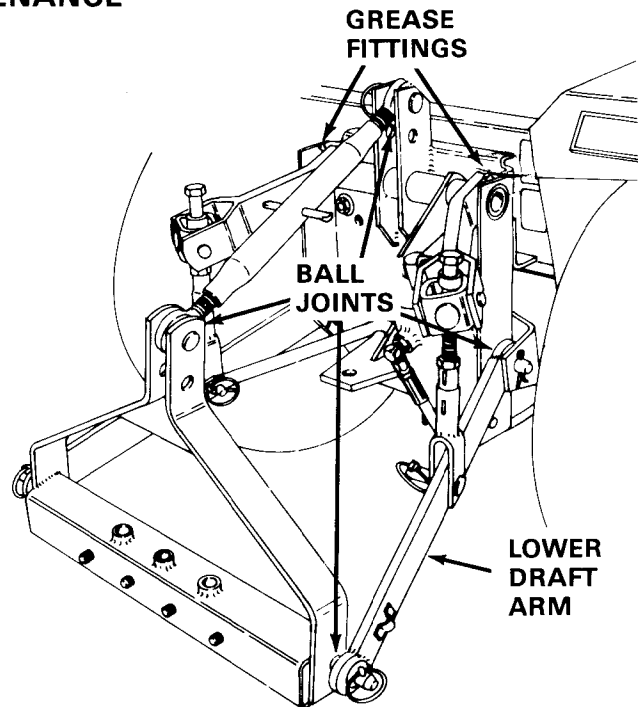

FIGURE 3

## INSTALLATION

1. Identify and inspect 3-Point hitch assembly for completeness before beginning installation. Keep hydraulic hose ends capped to prevent dirt entry.
2. Locate tractor on a clean, level surface such as a concrete garage floor.
3. Remove tow bracket from rear of tractor. Remove the pipe plug from the rear of the transaxle and install the flush plug.

**NOTE:** Leave bolts loose to insure proper alignment during installation. Tighten all bolts after installation is complete.

4. For 3000, 4000 tractors:
  - a. Remove two (2) rear seat support mounting bolts and washers.

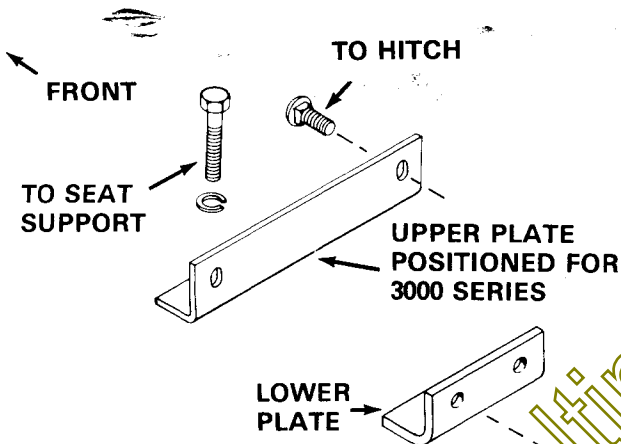

FIGURE 4

- b. Position the upper plate so it extends upward for 3000 series tractors (shown in Figure 7) and downward for 4000 series tractors (not shown). The upper plate should be fastened with the original bolt on the left side and a new 1/4 inch longer bolt (provided) on the right side.
- c. Position the lower plate so it extends under the transaxle casting as shown in Figure 5. Use the new 1-1/4 inch long bolts provided to secure the hitch and lower plate together.

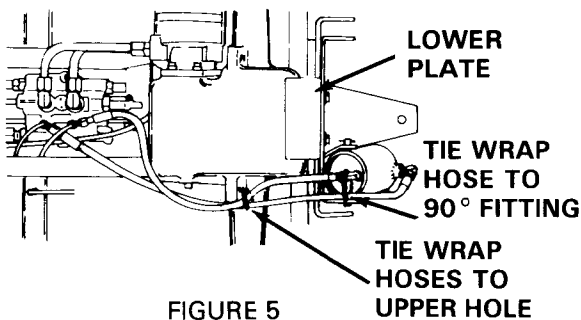

FIGURE 5

5. Install the hitch to the angle plates previously installed on 3000 or 4000 series tractors.

On 6000 series tractors, the hitch mounts directly to the rear of the transaxle housing.

6. Install the lower draft arms to the hitch plate using clevis pins and cotter pins. When correctly installed, the storage clip for the clevis pins on the draft arms should be to the rear and outboard.

**NOTE:** Loosen swivel nuts on cylinder fittings.

7. a. Install the short hose in the elbow fitting in piston end of 3-Point hitch cylinder. Tighten fitting.
- b. Install the long hose in the rod end of 3-Point hitch cylinder. Make sure this cylinder fitting is fully threaded into cylinder.
- c. Install the cylinder rod end up, elbow toward rear of tractor using the short pin (2) on the rod end and the long pin (3) on the piston end.

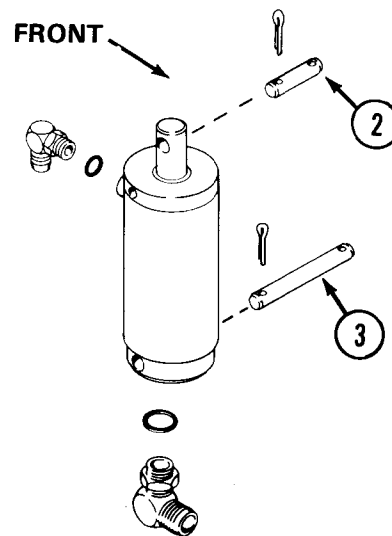

FIGURE 6

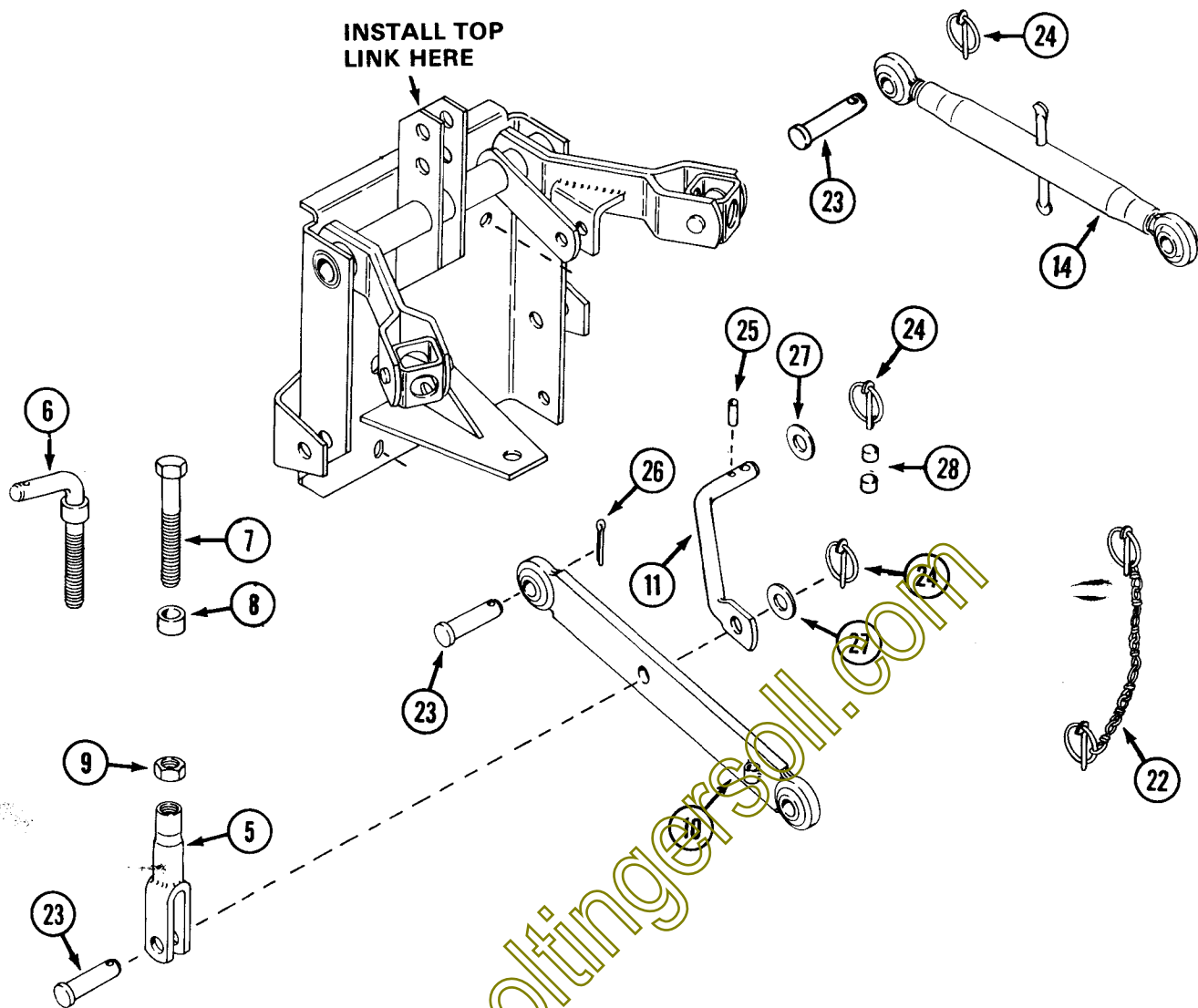

FIGURE 7

See Figure 7

8. Install the bolt (7) spacer (8) through the lift bracket on the lift arm of the rockshaft. Thread jam nut (9) and clevis (5) onto the threaded handle.
9. On early models install the threaded handle (6) through the lift bracket on the right side of the rockshaft. Thread clevis (5) onto the threaded handle.
10. Attach the clevis (5) to the lower draft arms (10) with the clevis pins (23).
11. Place a washer (27) over the drawbar end of the stabilizer (11) and secure the stabilizer between the left clevis and drawbar. Secure with click pins (24). Use the two spacers (28) to hold the click pin up at the drawbar.
12. On early models, the click pin chain assembly (22) should be used on the right side to secure the clevis pin and handle. This will prevent the handle from rotating and losing its adjustment.
13. Adjust the bolt (7) and handle (6) until the ends of the lower draft arms are four inches from the floor.
14. Install the top link (14) to the top hole in the hitch plate.
15. Place the travel and hydraulic lift levers in the neutral position.
16. Remove the belly pan, if equipped, from the tractor and place a clean pan under tractor travel and lift valve.





**CAUTION:** Hydraulic systems are highly pressurized. Escaping hydraulic oil, even an invisible pinhole leak, can penetrate body tissues causing serious injury. Use a piece of wood or cardboard when looking for leaks - never use the hands or other parts of the body.

Relieve hydraulic pressure before disconnecting circuits. When reassembling, make absolutely certain that all connections are tight.

If injured by hydraulic oil escaping under pressure, see a doctor immediately. Serious complications may arise if medical attention is not given at once.

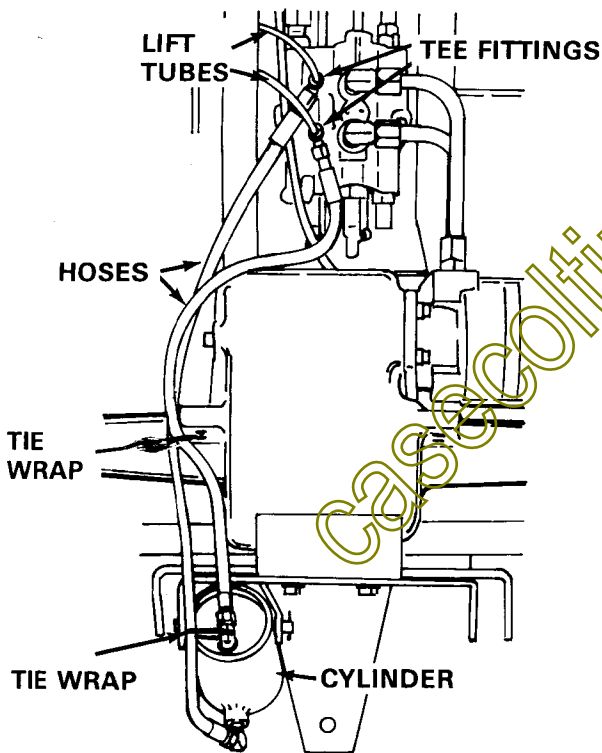

FIGURE 8

17. On 3000, 4000 series tractors, disconnect the hydraulic lift tubes from the travel and lift valve. On 6000 series tractors, remove the caps from the 90° fittings on the lift ports.

18. Loosely connect the hydraulic lift tubes to the tee fittings on 3000, 4000 tractors.

**NOTE:** Slight reforming of hydraulic lift tubes may be required.

For 3000, 4000 tractors, turn the tee fittings onto the lift port straight fittings of the valve. With the fittings facing rearward as shown in Figure 8 tighten the swivels against the lift port straight fittings tighten tubes.

19. Route the hose from the piston end of the cylinder under transmission and install to rear fitting in travel and lift valve.
20. Route hose from the rod end of the cylinder down under the transmission and install to front fitting in travel and lift valve.

Use plastic ties to fasten the hoses to the tractor frame.

21. Check and tighten all connections and swivel nuts as required.
22. Start the tractor and operate the cylinder to full open and closed positions several times to expel all air from the system. Shut off the tractor and check for oil leaks at all connections. Check the oil level in the reservoir and add if necessary to bring to proper level as described in tractor operator's manual.
23. Tire pressure should be checked and adjusted, if necessary, in accordance with the tractor operator's manual.

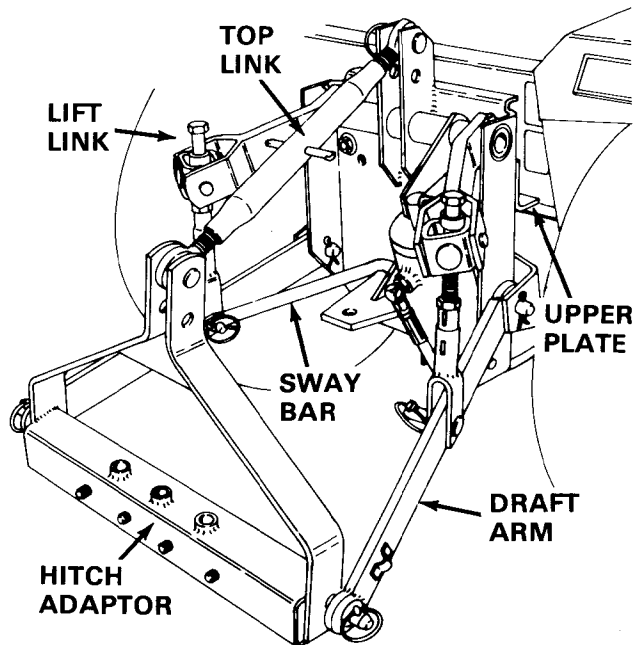

FIGURE 9

casecoltingersoll.com

**Operator's Manual Supplement**  
**For Three Point Hitch Model HH34**  
**Operator's Manual 8-56391**

**Note:** Use this supplement when installing an HH34 three point hitch on tractors listed below.

3014	14169364	and after
3016	14170087	and after
3018	14181200	and after
3018PS	14181900	and after
4016	14171450	and after
4020	14176856	and after
4020PS	14184000	and after

Disregard step 18 on page 9.

**INSTRUCTIONS**

1. Disconnect (2) attachment lift cylinder hydraulic lines from 45° fittings on travel valve.
2. Install (2) 218-5479 "T" fittings (provided in three point hitch parts bag) to 45° adaptor fittings.
3. Re-connect attachment lift cylinder hydraulic lines to "T" fittings as shown below.
4. Install (2) three point lift cylinder hydraulic lines on "T" fittings.
5. Tighten all fittings at this time.

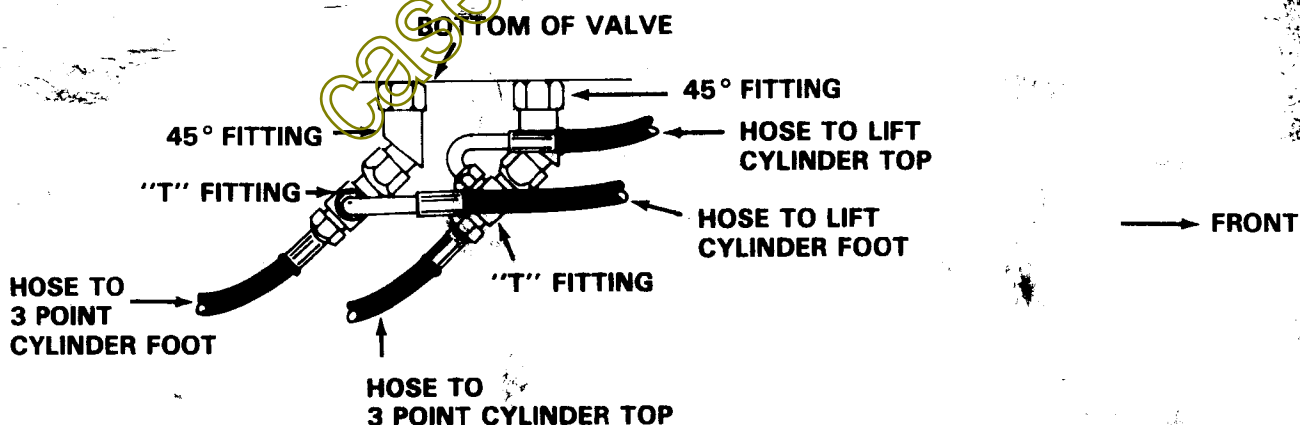

## TABLE OF CONTENTS

Safety Rules .....	4, 5
Introduction .....	6
Definition .....	6
Aeration .....	7
Seedbed Preparation .....	7
Cultivation and Weed Control .....	7
Orchard Cultivation .....	7
Landscaping .....	7
Mixing – Blending .....	7
Tiller Application Chart .....	8
Optional Equipment .....	8
Operating Controls .....	9
Operation	
Tiller Tine Rotation .....	10
Tiller Tine Speed .....	10
Lift Lever Operation and depth Adjustment .....	10
Tractor Travel Speed .....	10
Hydraulic PTO .....	11
Flow Control Valve .....	11
Adjustments	
Tire Pressure .....	12
Offset Mounting .....	12
Drag Shield .....	12
Retarding Chisel .....	13
Removable 9" Extension .....	13
Tine Cutting Edges .....	13
Tine Replacement .....	13, 14
Tiller Widths .....	15
Maintenance	
Visual Inspection .....	16
Tiller Chain Housing .....	16
Engine Air Cleaner .....	16
Engine Air Intake Screen .....	16
Engine Oil Level .....	16
Hydraulic Heat Exchanger .....	16
Mounting Rotary Tiller .....	17
Dismounting Rotary Tiller .....	18

## SAFETY RULES



The Safety Rules contained in this manual are to be used together with the safety rules appearing in the tractor operator's manual. Be sure to review both manuals carefully before operating the tractor-tiller combination.



**CAUTION:** Spinning Blade - Keep clear of the tiller tines when either the tiller or engine is running.



**CAUTION:** Keep children and pets away from the area while tilling.



**CAUTION:** Stop and inspect the tiller for damage immediately after striking a foreign object and repair any damage before restarting and operating the tiller.



**CAUTION:** Do not allow anyone other than the operator to ride on the tractor.



**CAUTION:** Remove debris that could be thrown by the tiller tines from the area to be tilled. Thrown objects could cause injury.



**CAUTION:** Put the Hydraulic PTO in neutral, lower tiller to ground, shut off engine, and set the parking brake before leaving the tractor seat.



Remember, a careful operator is always the best insurance against an accident. Always give complete and undivided attention to the job at hand.



**CAUTION:** Place the hydraulic PTO lever in neutral, stop engine and remove key before making repairs or adjustments.



**CAUTION:** Only operate controls while seated in the operator's seat.



**CAUTION:** Use extreme care when negotiating inclines and side slopes. Be sure to equip your tractor with a minimum of 115 pounds (52 kg) of front counterweight and 57-12 pounds (26 kg) of weight to each rear wheel for 200 series tractors and 150 pounds (68 kg) of front counterweight and 75 pounds (34 kg) of weight to each rear wheel for 400 series tractors with the tiller attached to obtain required overall stability.



Plan your tilling pattern ahead to leave ample room when leaving the plot. Start tilling operations away from close quarters or natural obstacles.



**CAUTION:** Hydraulic systems are highly pressurized. Escaping hydraulic oil, even an invisible pin-hole leak, can penetrate body tissues causing serious injury. Use a piece of wood or cardboard when looking for leaks - never use the hands or other parts of the body.

Relieve hydraulic pressure before disconnecting circuits. When reassembling, make absolutely certain that all connections are tight.

If injured by hydraulic oil escaping under pressure, see a doctor immediately. Serious complications may arise if medical attention is not given at once.

**IMPORTANT:** Always install new decals whenever the old decals are destroyed, lost, painted over or illegible. When individual parts are replaced that have decals attached, be sure to install a new decal with the new part.



**WARNING:** Be sure the Hydraulic PTO lever is in the neutral position before starting the tractor. This control is not equipped with a neutral start switch and accidental rotation of the tiller tines could cause injury.

**NOTE:** If your tractor is equipped with the optional flow control valve:



**CAUTION:** The optional flow control valve is NOT a hydraulic brake. For effective RETARD, the optional flow control valve lever should be placed in the full speed position and the tractor travel lever placed in the RETARD detent. Consult your tractor operator's manual.

casecoltingersoil.com

## INTRODUCTION

Read this manual carefully before operating your Hydraulically Driven Rotary Tiller, hydraulic PTO, and optional flow control valve (if so equipped). Your J I Case Compact Tractor Dealer is well qualified to answer any further questions you might have concerning your equipment. Also, if the need should arise, his service department with factory trained technicians, genuine Case replacement parts and the required facilities is in a position to provide proper repairs in the shortest time possible.

The definitions "Right, Left, Front and Rear" as used throughout this manual relate to the tractor, hydraulic tiller, hydraulic PTO and optional flow control valve (if so equipped) when the operator is seated facing forward in the normal operating position.

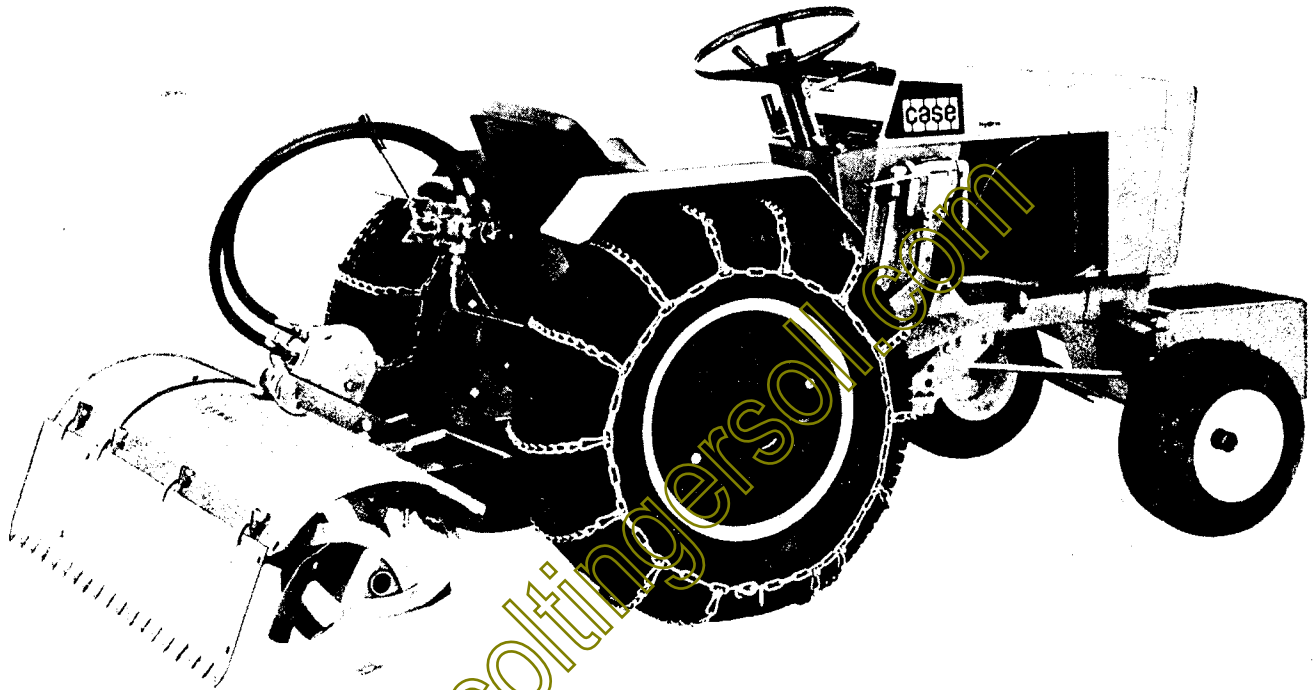

FIGURE 1

MODEL J-70 ROTARY TILLER SHOWN WITH MODEL 446 TRACTOR, J-17 HYDRAULIC PTO, L-19 FLOW CONTROL VALVE, H-13 FRONT WEIGHT BOX, K-10 REAR WHEEL WEIGHTS, E-16 TIRE CHAINS AND J-24 SLEEVE HITCH

### DEFINITION

A tiller is simply a mechanism for changing the condition of soil. The familiar moldboard plow performs a tilling function, but where the plow turns the soil in long folds or furrows the rotary tiller turns the soil in chunks or small particles ..... and therein lies the secret of the tillers' versatility. A rotary tiller can be used to perform any of the following functions:

1. Change soil physical conditions, such as in plowing, cultivating and aerating.
2. Control weeds by chopping and churning them into the soil.
3. Preparing seed beds by tilling the soil to a desired texture for optimum germination and plant survival.
4. Mix chemicals or organic matter such as fertilizer, manure, herbicides and insecticides into the soil.
5. Manage crop residue by turning it under to form mulch.
6. Modify soil topography such as in landscaping.
7. Cultivate or level ground around trees, hedges, or in orchards.
8. Blend various soils and soil modifiers for landscaping and greenhouse work.

## AERATION

For aeration purposes the tiller should simply disturb the soil surface without completely turning it over ..... in much the same manner as inserting a spade each few inches and loosening the soil in clumps. The surface of the soil should be left very rough, with occasional holes and deep fractures to several inches. This permits ready penetration of air and moisture with minimum danger of erosion or crusting. Previously tilled garden areas can be aerated by operating the tiller at comparatively rapid travel speeds ..... wherein the tiller almost "walks" with the tractor ..... tines should enter and exit the soil with minimum tearing and churning.

## CULTIVATION AND WEED CONTROL

Set the tiller for a shallow depth of one to two inches for cultivating and weed control activities. Avoid over-pulverization of the soil since this tends to "crust" with rain or "dust" away with wind.

## LANDSCAPING

Using the rotary tiller for landscaping purposes involves tilling the soil to a very fine texture to allow leveling or removal to another area. Several passes are usually required for this operation, particularly if the old lawn or field is well compacted and threaded with a dense root structure. Reducing the tiller width to 32" will also aid in initial surface penetration.

Fill ground should be tilled just prior to the application of top soil to aid in forming an interlaced structure between top soil and fill soil ..... to aid in water and root penetration.

## MIXING, BLENDING

Fertilizers, chemicals, manure, humus, old sawdust, compost or other growth producing soil additives can be effectively mixed into the soil by dispersing this material over the ground just prior to tilling. If the area to be tilled is tough then broadcast the additives between successive tiller passes to obtain most effective blending. Special purpose soil blends for potting, hothouse, greenhouse, or other applications can be quickly and easily developed with this tiller. Similarly, soil structure modifiers such as sand, gravel, sawdust and wood chips can be tilled into the soil to form a desired soil base.

## ORCHARD CULTIVATION

Periodic cultivation between hedgerows or tree rows will provide a continuous rough surface for greatest absorption of water.

The offset mounting and transferable extension features explained in the "Adjustment" section of this manual are particularly valuable for tilling under overhanging branches without barking the trees with the tractor.

Several passes with the tiller under nut trees, just prior to harvesting, will provide a smooth and clean surface for easiest harvesting ..... the nuts can be easily swept or raked without having to drag through weeds or grass.

## SEEDBED PREPARATION

Tilling for seedbed preparation requires a more thorough working of the soil structure to break it up into small enough particles to provide intimate contact between soil and seed. The ideal structure provides a relatively fine grained soil structure down to seed depth, with progressively coarser grained structure down to the full tilling depth. The interface between tilled and untilled strata should be rough to permit percolation of water ..... a smooth interface, like hardpan, tends to serve as a barrier to deep water and root penetration.

When preparing seedbeds it is generally necessary to use successive passes over the same area to achieve desired depth and texture ..... each successive pass provides a finer texture to the upper layers while adding to depth of penetration. Allow the tiller to "work" its way into the soil by keeping the tractor travel speed slow but steady, and offset your tilling path a few inches over from the previous path so that tines will till out the trail left by the chain case.

If the soil to be tilled is covered with growth first reduce it to a short length by mowing or other means. This will greatly reduce long grass or weeds from winding around the tiller tines. Another technique that improves tilling in heavy growth covered areas is to make one or two shallow passes to break up the root systems. Then wait about 48 hours for the material to dry out and for the root systems to weaken. The tiller will then be more effective in returning this material to the soil.

If the soil conditions are difficult or hard going, it is recommended that the outboard set of tines be removed. This will concentrate the tilling power to a smaller area and overcome difficult conditions.

You need to be aware that as soil dries out it increases in strength which will require more tilling to break it up. This is particularly true in clay and clay loam soils. The ideal condition for tilling is when the soil is in a friable condition. This can be identified as when there is enough soil moisture that the clods tend to crumble in your hand when squeezed. Proper soil and moisture conditions will increase performance and your satisfaction.



## TILLER APPLICATION CHART

TRACTOR MODEL	HITCH	HYD. PTO	OPTIONAL FLOW CONTROL	WHEEL WEIGHTS	HYD. LIFT	FRONT WEIGHTS	CHAINS
* 220, 222, 224	H-22 or J-22 Sleeve	J-17	† L-19	K-8	Required (Std on 224)	H-18 & K-8 or H-13 Box with 150# Ballast	D-12
444, 446	H-24 or J-24 Sleeve or H-26 3-Pt + F-27 Sleeve Adapter	J-17	† L-19	K-10	Standard	H-18 & K-10 or H-13 Box with 150# Ballast	E-16
644	LT-26 3-Pt. Hitch + F-27 Sleeve Adapter	LK-17	Not Available	K-10	Standard	** Not Available	LT-15
646	LT-26 3-Pt. Hitch + F-27 Sleeve Adapter	LT-16	Not Available	D-10	Standard	** Not Available	LT-15

\* Model 220 should be equipped with a Tiller only in light or sandy soil.

\*\* Apply 150# ballast to front bucket.

† Tractors with mufflers under the hood only. For mounting to prior model tractors, consult your dealer.

### OPTIONAL EQUIPMENT REQUIRED FOR BEST PERFORMANCE

The Tiller Application Chart above provides a listing of the currently available equipment. Proper weighting of the tractor is imperative to achieve satisfactory results. Rear wheel weights and tire chains provide improved traction and stability. Front end weights will provide improved stability and steering control of the tractor. If the front weight box is used, approximately 150 pounds of ballast should be added.



**CAUTION:** Use extreme care when negotiating inclines and side slopes. Be sure to equip your tractor with a minimum of 115 pounds (52 kg) of front counterweight and 57.1-2 pounds (26 kg) of weight to each rear wheel for 200 series tractors and 150 pounds (68 kg) of front counterweight and 75 pounds (34 kg) of weight to each rear wheel for 400 series tractors with the tiller attached to obtain required overall stability.

## OPERATING CONTROLS

The principle components and controls of your rotary tiller are identified in Figure 2 with the same nomenclature used throughout this manual.

The tiller tines are placed in motion by engaging the Hydraulic PTO lever. Tractor ground speed is controlled by the tractor travel lever or by a combination of the tractor travel lever and optional flow control valve if so equipped. The range selector should always be in low range when tilling.

The tiller is raised and lowered with the attachment lift lever.

Tilling should always be done with the engine at full throttle to achieve maximum power, maximum tine speed and prevent engine lug down and subsequent overheating.

After hard usage, allow the engine to run at 1/3 throttle for two to five minutes to allow engine parts to cool evenly before shutting off.

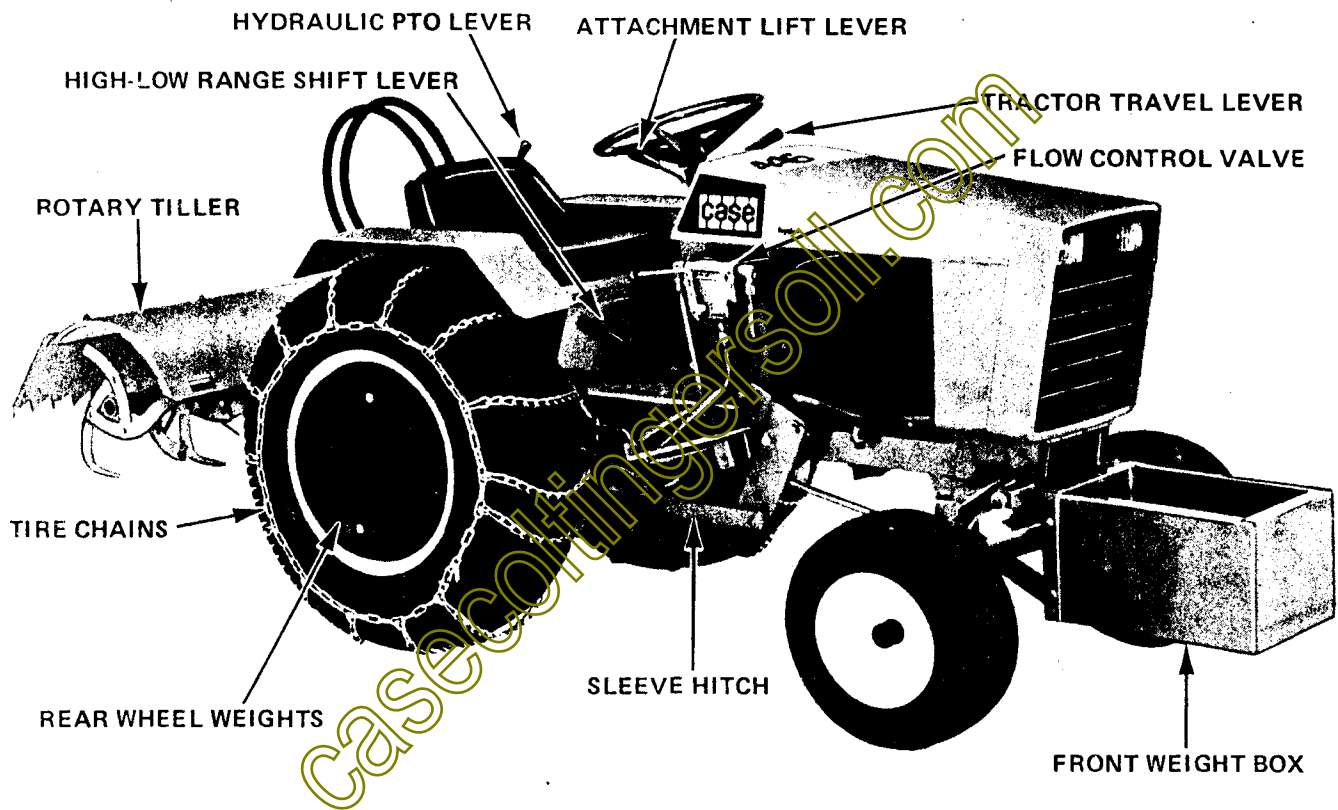

FIGURE 2

## OPERATION

### TILLER TINE ROTATION

#### NEUTRAL – FORWARD – REVERSE

When the tiller directional control valve is in the center or neutral position, the oil circulates freely without operating the tiller. When the control lever is pushed forward, the oil is directed to the hydraulic motor on the chain case to operate the tines in forward rotation. To reverse the tine rotation, simply move the control lever to the rear from the neutral position ..... this directs the oil through the hydraulic motor in the opposite direction. The control valve can be shuttled from full forward through neutral to full reverse without adverse effect ..... permits dislodging of rocks, roots or other objects.

#### TILLER TINE SPEED

Always operate the tiller with the engine at full throttle (3600 RPM) to provide maximum tine speed for most effective tilling, high horsepower and adequate engine cooling.

Maintain close observation of the rotating speed of the tiller tines while tilling. Should soil conditions slow the tine speed, reduce tractor ground speed accordingly until tine speed returns to full RPM.

Remove the 9 inch extension in severe conditions or lift the tiller slightly to maintain high tiller tine speed. See Adjustments, Page 12 of this manual.

#### LIFT LEVER OPERATION AND DEPTH ADJUSTMENT

The tiller is raised and lowered with the hydraulic lift control lever. Since the tiller is a heavy attachment, hydraulic lift is necessary on the tractor.

The hydraulic lift control lever has three operational positions, raise, lower, and float. The lever returns automatically to neutral from the raise and lower positions. The lever is held by a detent in float and must be removed manually.

If held in the "lower" position, down pressure on the tiller may be developed. This should be avoided when tilling because applying down pressure to the tiller will, in effect, remove weight from the rear wheels of the tractor and reduce traction and stability.

Adjust the depth of the tiller with the hydraulic lift lever. Do not attempt to till at maximum depth in the first pass especially when converting from grass or fallow land to a first time garden. Prepare the seedbed by tilling in successively deeper passes. The depth at each pass should be determined by soil conditions and power available from the tractor. If soil conditions slow the tiller tine speed, raise the tiller slightly or reduce tractor ground speed appropriately to prevent engine lug down or tiller walking the tractor.

Final passes with the tiller may be made with the hydraulic lift control lever in the float position to achieve maximum depth.

#### TRACTOR TRAVEL SPEED

Ground travel speed should be kept slow to insure a good tilling job. Always till with the two speed transaxle in low range.

The tractor ground speed is controlled with the travel lever. By manipulating the travel lever to counteract the forces of the tiller a fine control of ground speed can be maintained. Push down slightly on travel control lever to permit smoother response. The travel lever may be moved from forward to reverse without hesitation to aid in controlling ground speed.

**IMPORTANT** DO NOT BACK UP WITH THE TILLER LOWERED AS DAMAGE TO THE TILLER AND DRAG SHIELD WILL RESULT.

#### HYDRAULIC PTO

Moving the Hydraulic PTO handle forward causes the tiller tines to rotate forward. Moving the handle rearward causes the tines to rotate in reverse. If the tine rotation is the opposite of this, refer to the Mounting section of this manual for proper valve to tiller motor hose hook-up.

Always move the PTO handle full travel to insure maximum speed and power to the tiller.

The Hydraulic PTO may be left on the tractor when the tiller is removed.

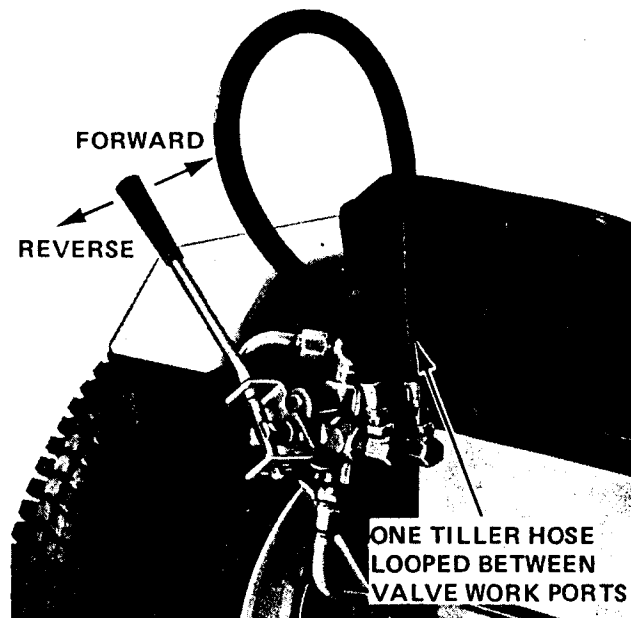

FIGURE 3 HYDRAULIC PTO

The Hydraulic PTO may be used to drive other hydraulically driven devices. Consult your dealer for further information.

**VERY IMPORTANT** Only operate the tractor with tiller hoses connected or one hose looped between the valve work ports.

Failure to observe this procedure will result in oil loss (ports left open) or pump damage (ports plugged) if the valve is actuated.

#### OPTIONAL FLOW CONTROL VALVE

The optional flow control valve provides more precise ground speed control when the tiller is used in adverse soil conditions or for commercial users. This is accomplished by metering oil to the tractor travel valve. The amount of metered oil depends on the position of the control valve handle and does not change with pressure requirements at the tractor drive motor.

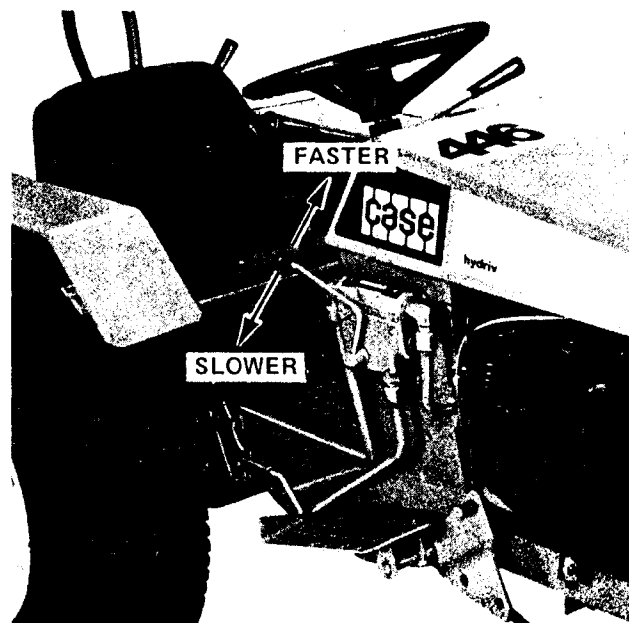

FIGURE 4 FLOW CONTROL VALVE



**CAUTION:** The optional flow control valve is NOT a hydraulic brake. For effective RETARD, the optional flow control valve lever should be placed in the full speed position and the tractor travel lever placed in the RETARD detent. Consult your tractor operator's manual.

Proper use of the optional flow control valve is as follows:

1. Position the optional flow control valve lever all the way rearward (off).
2. Position the tractor travel lever full forward (or reverse if desired).
3. Move the optional flow control valve lever forward to obtain the desired ground speed.
4. The tractor travel lever may be moved from forward to reverse or neutral with the optional flow control valve lever in any position.
5. The optional flow control valve lever may be left in the full speed position and travel speed and direction may then be controlled solely with the travel control lever.
6. The hydraulic attachment lift WILL NOT function with the optional flow control valve lever in the off position. The speed of the hydraulic attachment lift is directly related to the optional flow control valve lever position.
7. Maximum obtainable ground speed may be slightly less on a tractor equipped with the optional flow control valve.

## ADJUSTMENTS

**TIRE PRESSURE:** Inflate tractor tires to the pressure specified below:

<u>Tire Size</u>	<u>Type</u>	<u>PSI</u>	<u>k Pa</u>	
6:50 x 8	Front (High flotation)	14	96	With front end weight applied
8:50 x 12	Rear (High flotation)	10	68	With rear wheel weights and tiller mounted
8:00 x 16	Rear (High flotation)	14	96	With rear wheel weights and tiller mounted
5:70 x 8	Front - Transport	45	310	
8:50 x 15	Rear - Traction	14	96	With rear wheel weights and tiller mounted

**OFFSET MOUNTING:**

Alternate hole locations in the hitch permit offsetting the tiller 3 inches to the right. This allows more precise control of the tiller when operating along plant rows or fence lines. Figure 5 shows how this is done with a sleeve hitch adapter. The same thing may be done with a sleeve hitch.

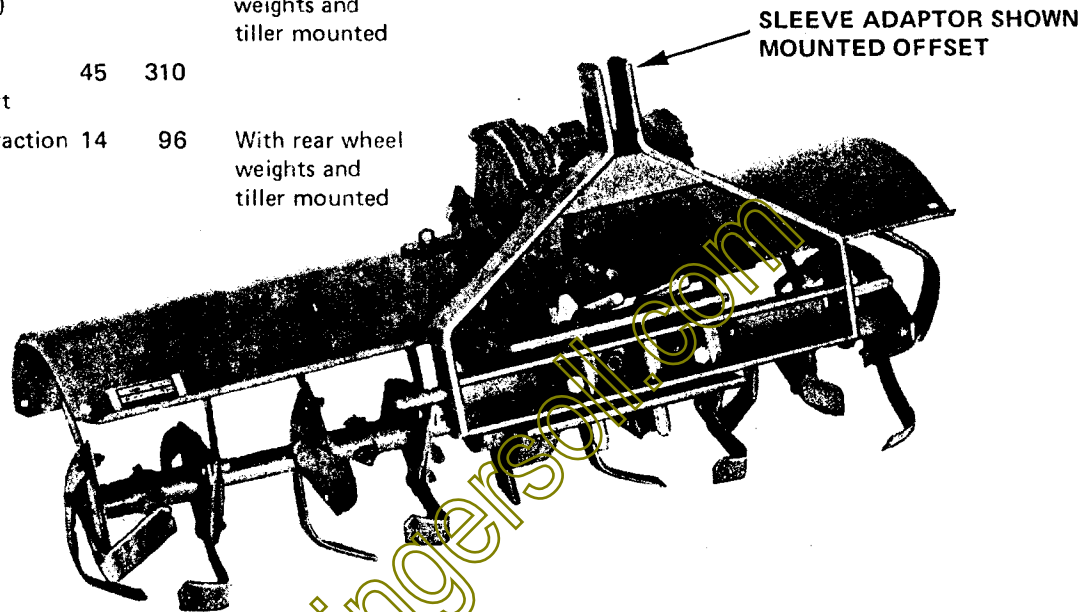

FIGURE 5 OFFSET MOUNTING

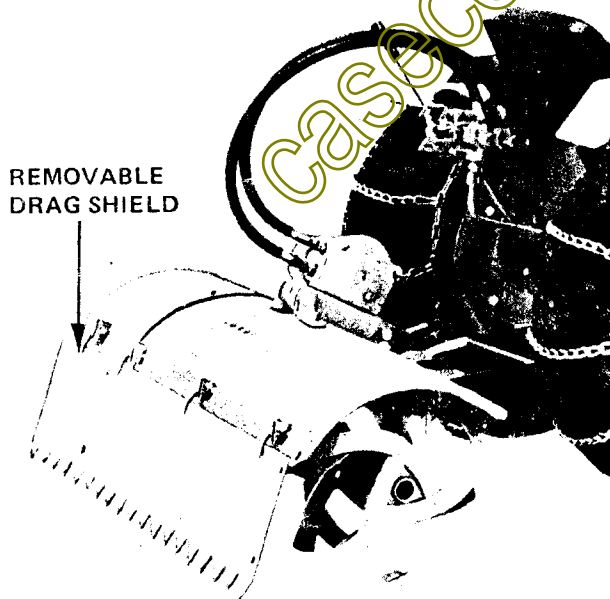

FIGURE 6 REMOVABLE DRAG SHIELD

**DRAG SHIELD:**

The drag shield in its normal position serves as an additional means for breaking up the soil to a finer, uniform texture. The trailing serrations even out the tilled soil to leave a smooth surface, ready for lawn seeding or garden planting. The shield is easily removable for tilling in paddies, for rough tilling or aerating as you prefer. Refer to the assembly section of this manual for the correct drag shield removal and replacement procedure.

## RETARDING CHISEL:

A retarding chisel is included with the tiller for mounting behind the chain case. This chisel aids in tractor speed control for some tilling conditions. By installing this chisel angled ahead and slightly above the cutting level of the tiller tines, it will help to prevent the tiller from driving the tractor too fast, and it will also

break up the ridge under the chain case. The chisel can also be used for limiting tillage depth by setting it under the tine cutting level and angling it to the rear. There is little need for the chisel when using the tiller for normal tilling, weed control and aeration or if operating the tiller in reverse rotation.

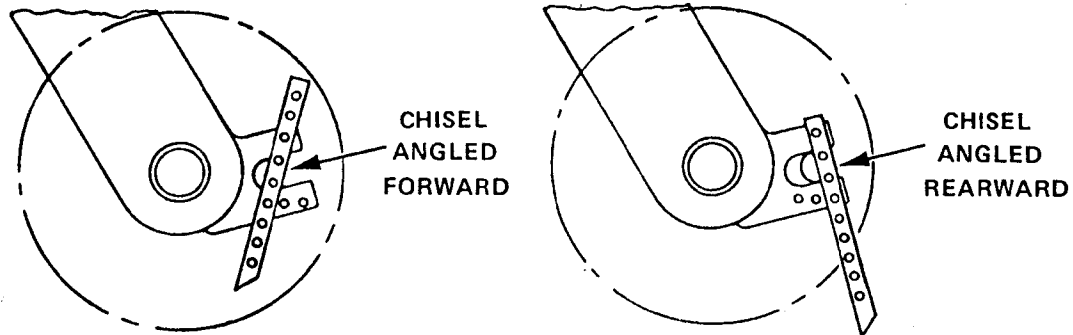

FIGURE 7 APPLICATIONS FOR RETARDING CHISEL

## REMOVABLE 9" SECTION:

Some soils are very hard, or dense with root structures resulting in extremely difficult tilling conditions. The left hand shaft and shield assemblies can be easily removed to reduce the tiller width to 32 inches for such difficult tilling conditions. At this reduced width the tiller will penetrate faster and will use tractor horsepower more efficiently.

The extension can be replaced after initial surface tilling has been completed. See Figures 8 and 11 for details on how to remove the left extension assemblies.

## TILLER TINE CUTTING EDGE:

The tiller tine cutting edges should be sharpened periodically for best results.

## TILLER TINE REPLACEMENT:

This tiller is assembled at the factory with the precise placement of each tine to achieve proper radial timing and overlapping of cutting paths. The timing and overlapping are critical ingredients to optimum tiller production and smooth operation, therefore, removing individual tine blades is not recommended except for replacement or reverse rotation tilling purposes.

All three tines on each outer hub plate point in toward the center of the tiller. This provides a smooth, well defined edge of cut, reduces the amount of "kick out" of material and permits closer tilling and cultivating to plants without catching foliage on the tine ends.

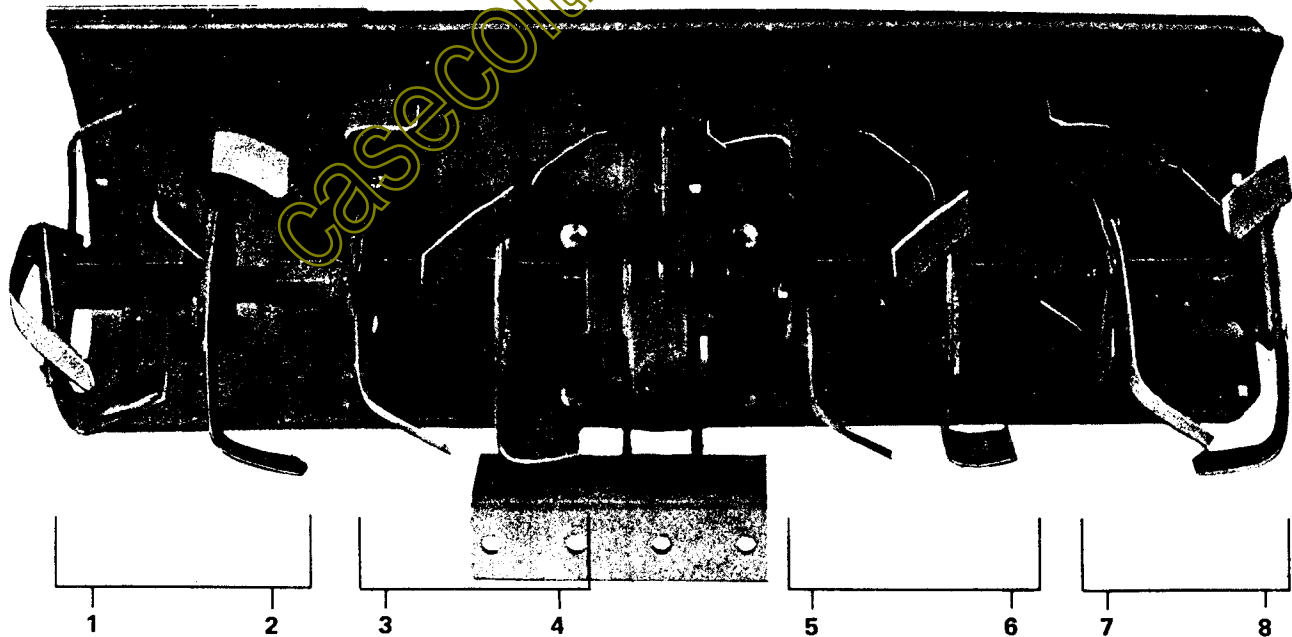

FIGURE 8 TINE SECTIONS AS ASSEMBLED AT THE FACTORY WITH EXTENSION ON LEFT SIDE TO TILL OUT BOTH WHEEL TRACKS

The tiller, including extension, consists of four individual sections, each having six removable tines and two welded triangular mounting plates. One of the corners on each mounting plate has a "flat" (Refer to Figure 10) where an identification number is stamped. With the extension on

the left side as shipped from the factory the mounting plates from left to right are numbered in sequence "1" through "8" as shown in Figure 8. Operating in this manner results in 41" width and both wheel tracks will be removed if the tiller is centered on the hitch.

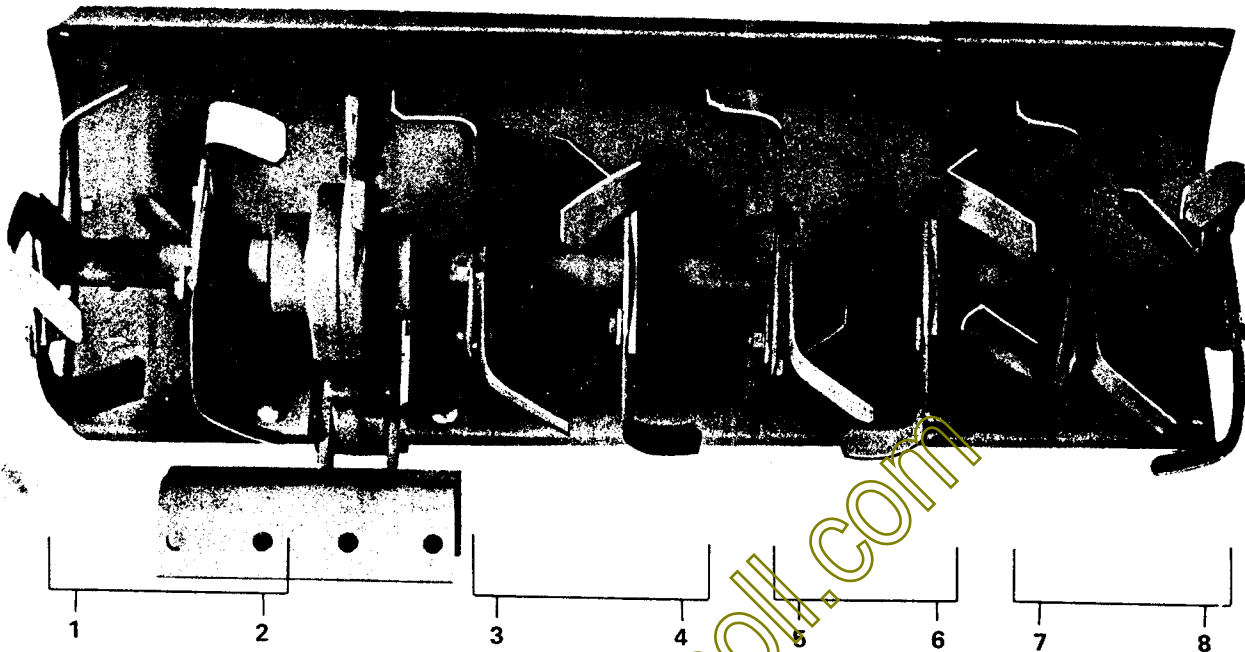

FIGURE 9 TINE SECTION 3 and 4 CONVERTED TO RIGHT SIDE FOR OFFSET TILLING

If required, tine section "3" and "4" can be removed, converted and installed as the center section on the right side as shown in Figure 9 for offset tilling. Remove, reverse and reassemble the tines as illustrated in Figure 10.

If fine mulching and side hilling are desired, the tines can be unbolted from their mounting plates and reinstalled so they will cut with reverse rotation. When reversing the tine mountings, interchange the tines between mounting plates "1" and "8" so the end tines will all point inward. For all other mounting plates, arrange the tines for maximum distance between them and each plate should have one "R" with two "L" tines, or two "R" with one "L" ..... do not install three "R's" or three "L's" on the same mounting plate. Use Figure 8 for reference when converting back to "forward rotation."

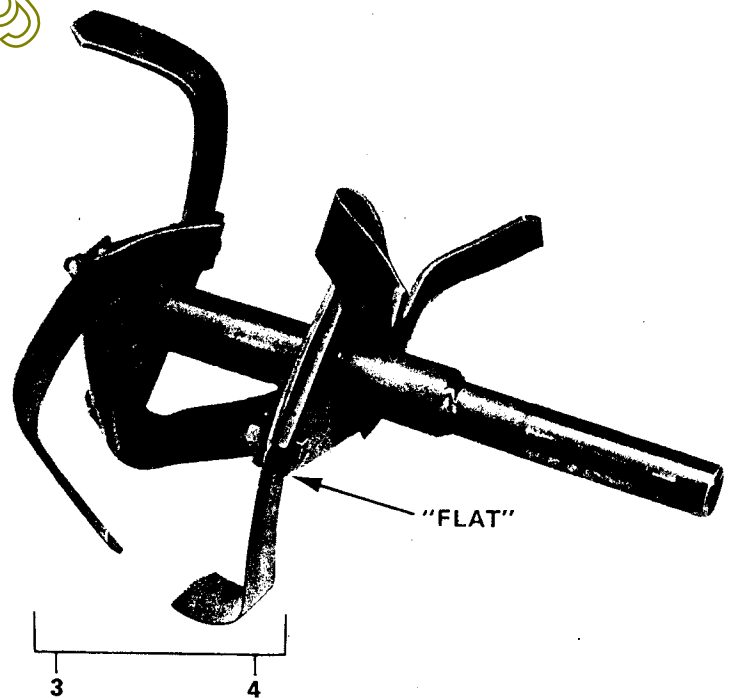

FIGURE 10 SECTIONS 3 and 4 ILLUSTRATING TINES CONVERTED FOR OFFSET MOUNTING TO RIGHT SIDE OF BASIC TILLER

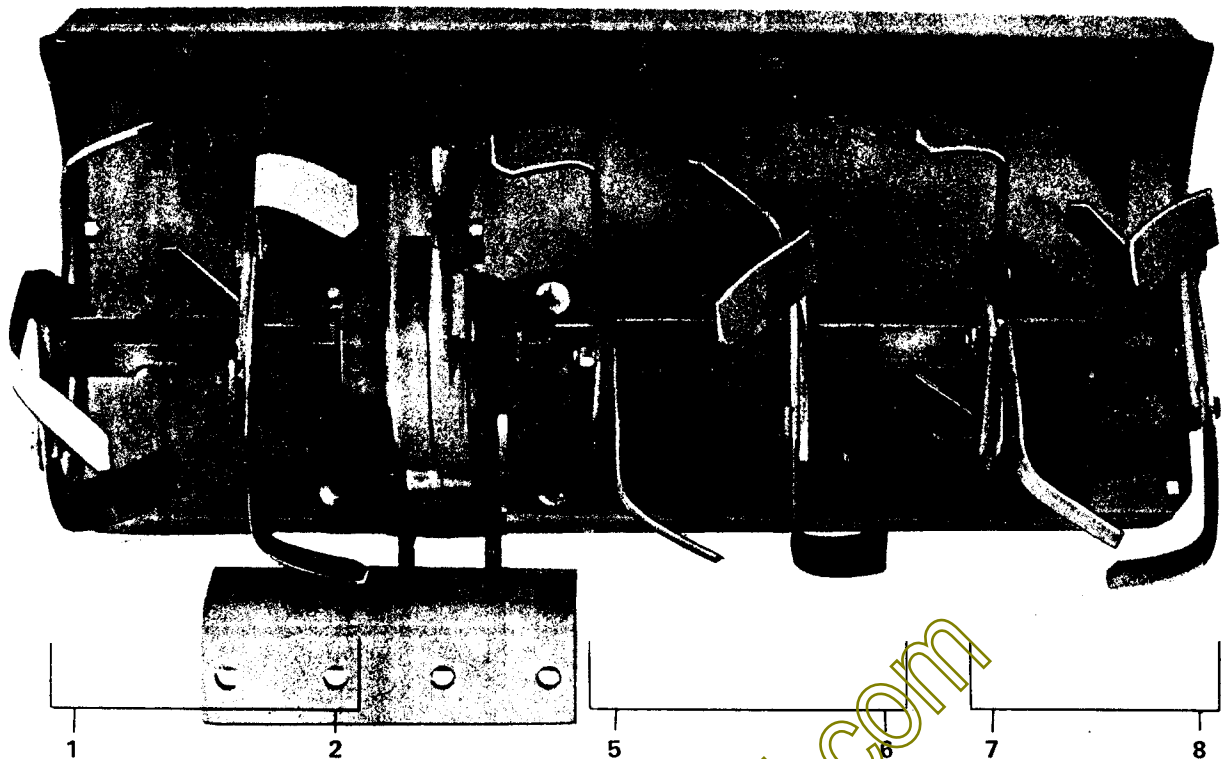

FIGURE 11 TILLER REDUCED TO BASIC 32" WIDTH (TINE SECTION 3 and 4 IS REMOVED)

**TILLER WIDTHS:**

Figures 8 and 9 illustrate the tiller at full 41" cutting width. Very tough tilling conditions, or narrow crop row widths will often require reducing the tiller width from the maximum 41". Individual tine sections can be removed or shifted, resulting in a variety of combinations.

1. 32" Tilling Width - Remove tine section "3 and 4" and relocate section "1 and 2" next to left side of chain case as shown in Figure 11. This reduces the tiller to a basic 32" cutting width with the right wheel track tilled out.
2. 19" Tilling Width - Remove both tine sections from either side of the chain case. This results in 19" of cutting width and tills out the wheel track on whichever side the remaining two sections are mounted.

3. 27" Tilling Width - Remove section "1 and 2" altogether. Convert section "3 and 4" as shown in Figure 9 and relocate to the right side of the chain case. This results in 27" of cutting width with tine section "7 and 8" offset.

**NOTE** This is an ideal width adjustment where the job calls for offset tilling and conditions are too severe for full 41" cutting width. In addition to obtaining 27" of cutting width with this tine arrangement there will not be an untilled strip left under the chain case.

4. Several other "spacing" combinations can be arranged to match your gardening requirements. Always replace worn tines with genuine CASE replacement parts.



## MAINTENANCE

### VISUAL INSPECTION:

Check all bolts, retainers, and hydraulic connections daily for tightness. Tighten as required. Check for bent or damaged tines or shields and repair as necessary.

### TILLER CHAIN HOUSING:

The chain housing is properly filled with multi-purpose gun grease at the factory and will normally not require further servicing. An inspection plug is located on the upper right side of the chain housing and grease can be added at this point if necessary. Check the chain housing for lubricant at the start of each season or if there is any evidence of leakage.

### ENGINE AIR CLEANER:

The air cleaner element should be removed daily and carefully tapped on a flat surface to dislodge dust and other foreign particles. Replace the element when there is evidence that it has become saturated with dust that will not tap out. A precleaner is

available from your Authorized Case Dealer and will extend the life of the air cleaner element.

### ENGINE AIR INTAKE SCREEN:

Check and brush off all dirt and debris daily or more often if necessary.

### ENGINE OIL LEVEL:

Check engine oil level daily. Keep level between the marks on the dipstick. Do not overfill. Refer to your tractor operator's manual for oil specifications and oil change intervals.

### HYDRAULIC HEAT EXCHANGER:

Check and brush or blow all dirt and debris away from the grille and cooling fins daily or more often if necessary.

TILLER ASSEMBLY

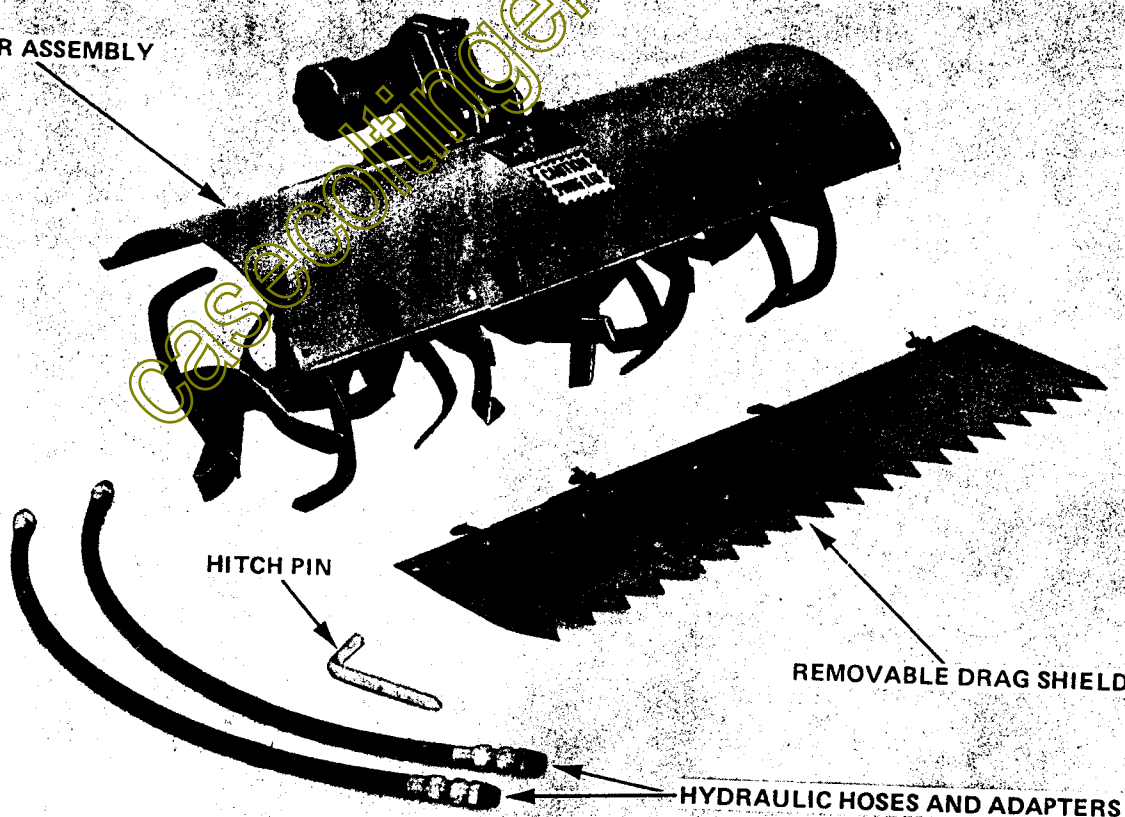

FIGURE 12 MODEL H-70, J-70 TILLER -- DISASSEMBLED

## MOUNTING THE ROTARY TILLER

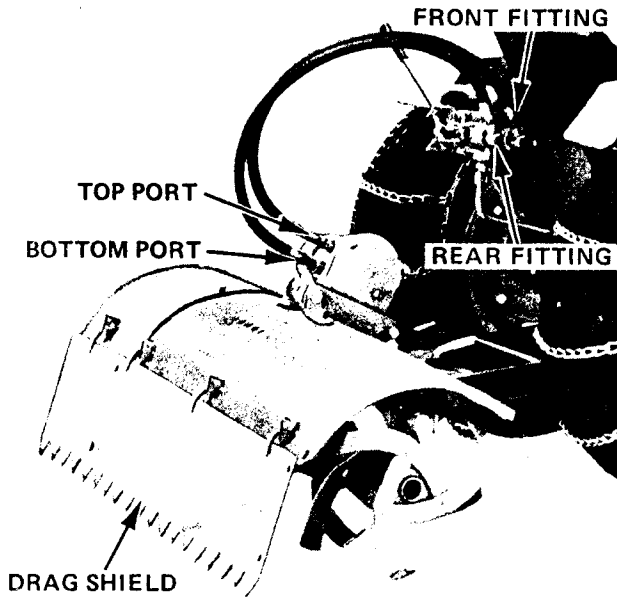

FIGURE 13 TILLER HOSE CONNECTIONS

Refer to the Tiller Application Chart on page 8 to make sure your tractor is equipped with the proper hitch, weighting and hydraulic lift.

1. Position the tiller on the hitch and anchor with two anchor pins.
2. Install hose adapter into tiller hydraulic motor work ports. Install hoses from the two side ports on the valve to the two work ports in the tiller hydraulic drive motor. The front hose on the valve should go to the top port and the rear hose on the valve should go to the bottom port in the tiller hydraulic drive motor. Refer to Figure 13.
3. Tighten the two stabilizer bolts through the hitch and against the tiller mounting bracket. See Figure 14.
4. Connect the drag shield to the mounting lugs on the tine shield and secure with two plain washers and cotter pins. Refer to Figure 13.
5. Start the tractor, raise the tiller, and check for proper tine rotation. When the PTO valve lever is moved ahead, the tines should turn in forward rotation. Should rotation be opposite, reverse the hoses on the hydraulic motor fittings.

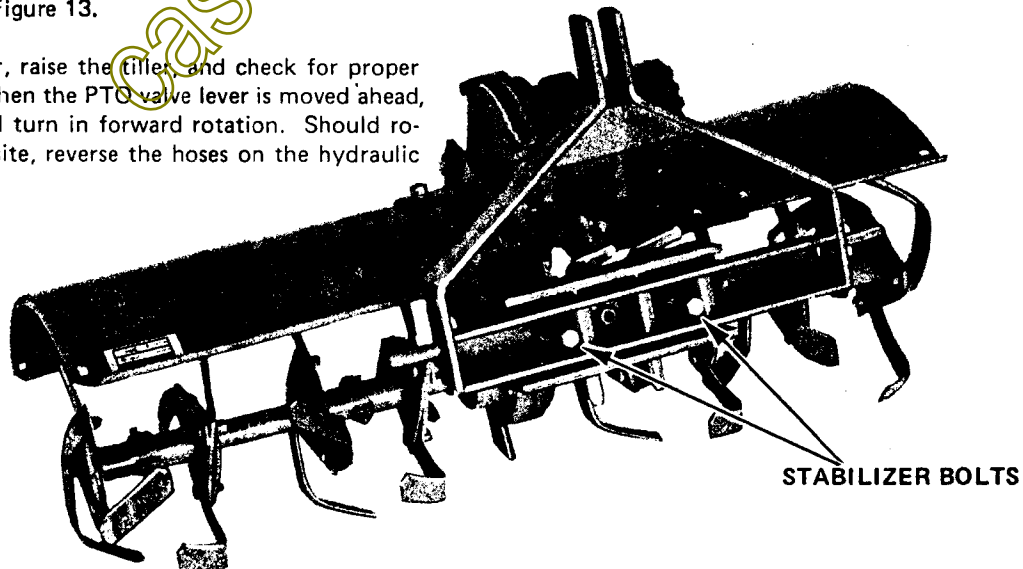

FIGURE 14 TILLER AND F-27 SLEEVE ADAPTER SHOW MOUNTED OFFSET 3 INCHES TO THE RIGHT.



**CAUTION:** Place the hydraulic PTO lever in neutral, stop engine and remove key before making repairs or adjustments.



**CAUTION:** Only operate controls while seated in the operator's seat.



**CAUTION:** Hydraulic systems are highly pressurized. Escaping hydraulic oil, even an invisible pin-hole leak, can penetrate body tissues causing serious injury. Use a piece of wood or cardboard when looking for leaks - never use the hands or other parts of the body.

Relieve hydraulic pressure before disconnecting circuits. When reassembling, make absolutely certain that all connections are tight.

If injured by hydraulic oil escaping under pressure, see a doctor immediately. Serious complications may arise if medical attention is not given at once.

6. Check all hydraulic connections for leaks and all valve and tine mounting bolts for tightness.
7. Check the oil level in the tractor hydraulic reservoir. Add, as necessary. Refer to Tractor Operator's Manual for proper oil level and specifications.

## DISMOUNTING THE ROTARY TILLER

1. Lower the tiller to the ground.
2. Loosen the two stabilizer bolts.
3. Disconnect one hose from the Hydraulic PTO valve and hold it elevated to minimize oil loss.
4. Disconnect the other hose from the hydraulic tiller drive motor and hold it elevated to minimize oil loss.
5. Loop each hose around to the available fitting and reconnect.

**VERY IMPORTANT**

When tiller is removed, one hose must be looped between the hydraulic PTO valve ports. Failure to observe this procedure will result in oil loss (ports left open) or pump damage (ports plugged) if the valve is actuated.

6. The hydraulic PTO and optional FLOW CONTROL may be left installed on the tractor.

**NOTE:** The J I Case Company reserves the right to make improvements in design or changes in any obligations to install them on units previously sold.

ONE TILLER HOSE  
LOOPED BETWEEN  
VALVE WORK PORTS

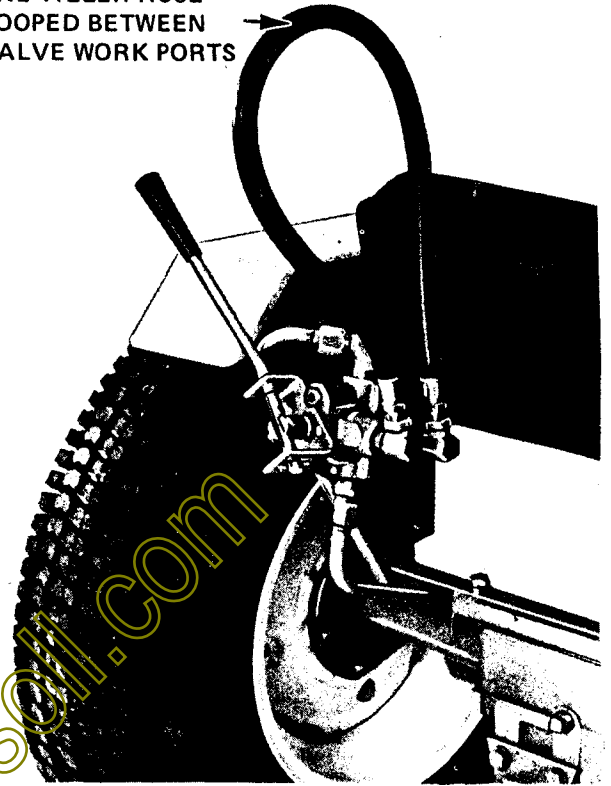

FIGURE 15 HYDRAULIC PTO