

Operator's Instruction Manual

WITH SET UP INSTRUCTIONS

MODEL C-36S, CT-36S, C-48S and CT-48S SNOW BLOWERS

FOR: CASE 130 and 180 COMPACT TRACTORS
COLT DELUXE, SUPER, SUPER H and
RANCHER COMPACT TRACTORS

MODEL D-36S, SB-36, D-48S and SB-48 SNOW BLOWERS

FOR: CASE 120, 150 and 190 COMPACT TRACTORS
COLT 2110, 2310, 2510 and 2712 COMPACT
TRACTORS



J. I. CASE. CO.

RACINE, WISCONSIN U.S.A.

IMPORTANT

SUPPLEMENTAL SET UP INSTRUCTIONS COVERING

MODEL D36S, SB36, D48S and SB48 SNOW BLOWERS

NOTE Follow the Set Up Instructions pages 17 to 24 in the C36S and C48S Manual attached with the exceptions listed below.

1. Page 21, Par. 1 should read: Install the Stabilizer bracket to the implement lever cross shaft on the tractor and secure with two (2) hair pins. Follow paragraph 2 on page 21.

2. Page 21, Par. 3 should read: Connect the stabilizer bracket to the lift pivot bracket using two (2) $3/8 \times 1-1/2$ " cap screws, pivot bushings and lock nuts. Follow paragraphs 4 through 11 on pages 21 and 24.

NOTE Be certain the gear box is correctly installed. The longer (input) shaft ($2-1/2$ ") is connected to the engine drive belt and the shorter (output) shaft (2") operates the auger jack shaft drive belt.

3. Disregard paragraphs 12, 13 and 15 on page 24.

4. Before proceeding with the instructions in paragraph 16, install the triangle shaped bracket to the two forward holes in the tractor left lever using the two $1/2$ " bolts, lockwashers and nuts.

5. Check the lubricant level in the gear box. The level check plug is located on the outside of the gear box about two-thirds up. Lubricant level must be maintained within $1/4$ " below the check plug opening. Advise the customer to recheck the lubricant level every 40 hours or 30 days operation and add, if necessary, using SAE #90 Gear Lubricant.

FOREWARD

Your Tractor is now equipped with a rugged and reliable snow blower for that winter snow removal task. The Snow Blower has been designed for easy operation and maximum snow removal. It is suggested that you read the safety, adjustment, operating, and maintenance suggestions in this manual thoroughly before operating the Snow Blower. By following the suggestions outlined in this manual, you will prolong the life of the Snow Blower and maintain its maximum efficiency.



HI FOLKS!-I'm Sammy Safety.
Look for me to point out
important Safety Precautions

NOTE

Terms left and right, as used in this manual, refer to the left and right sides of blower when facing forward from the operator's seat.

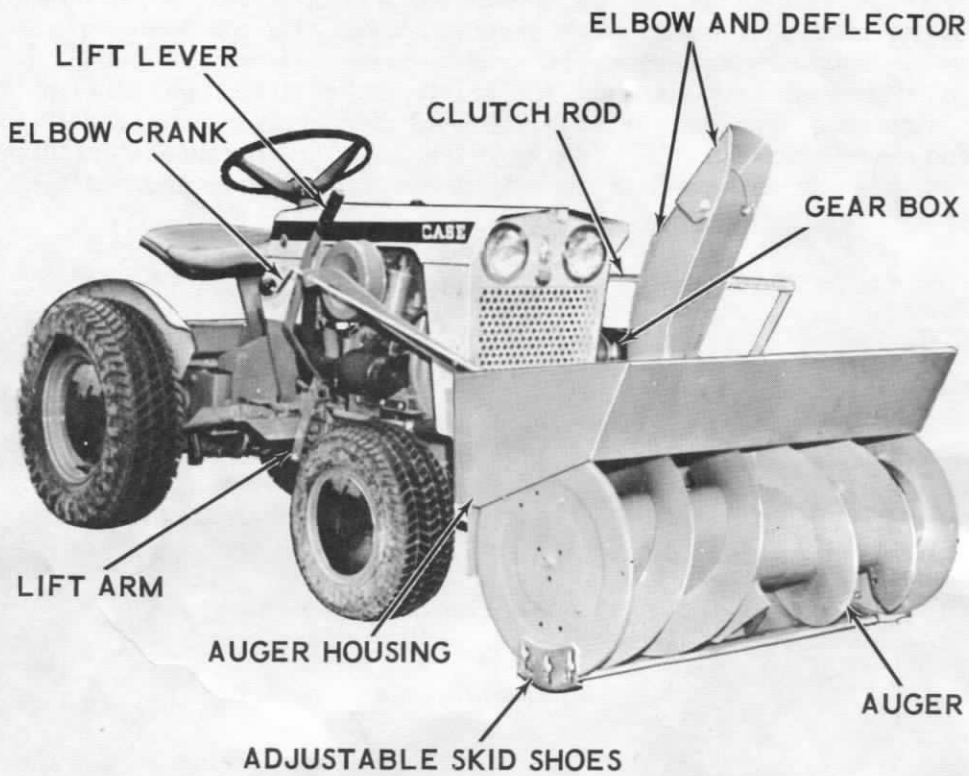

Figure 1. Model C36S Snow Blower on Case 130 Tractor

NOTE The J. I. Case Company reserves the right to make improvements in design or changes in specifications at any time without incurring any obligation to install them on units previously sold.

BEFORE PLACING BLOWER IN OPERATION

1. Check all screws and nuts for proper tightness and make certain that all parts are properly assembled.
2. Test all controls for smooth operation.
3. Read Safety and Operating Suggestions carefully for safe and proper use of blower.

NOTE

The blower is pre-lubricated at the factory and is ready for immediate operation. Refer to lubrication instructions for location of lubricating points and required lubricant.



CAUTION

Never attempt to service or make adjustments while the snow blower is operating.

BLOWER OPERATING CONTROLS AND ADJUSTMENTS

(See Figure 1)

Operation of the blower is accomplished by three separate controls: clutch rod, elbow crank, and tractor lift lever. All controls are within easy reach from the operator's position on the tractor.

Clutch Rod

Located on left side of tractor, starts and stops rotation of auger.

To Start

Disengage hook on clutch rod from guide arm and allow rod to move back through guide in arm. Do not let clutch rod "snap" back. Allow clutch rod to move back slowly until idler pulley rests firmly on drive belt.

To Stop

Push clutch rod forward until hook passes through guide in the arm. Allow rod to move back until hook on rod engages with the guide.

Elbow Crank (See Figure 1)

Right hand side. Turn crank to the right or the left to change direction of snow discharge. Full 180° rotation, 90° right, front and 90° left.

Tractor Implement Lift Lever

Located on right side of tractor and is used to raise and lower blower. By pulling lever back and locking in rear notch in quadrant, auger is raised into transport position. Moving lever forward places blower in operating position. Lift handle must be in full forward position to allow the blower to float. Also keep the lift release lever depressed with right heel to insure floatation.

OPERATING ADJUSTMENTS

CAUTION

When making any adjustments on the snow blower, turn tractor engine off.

Lift Spring Adjustment (See Figure 2)

The function of the lift spring is to adjust the amount of weight of the auger when lowered in operating position. The greater the spring tension the less the auger weighs allowing auger to float on a rough or uneven surface. Decreasing spring tension increases auger weight reducing the amount of floating action and allowing auger to clean close on a smooth, level surface. The following adjustment is recommended as a starting point. After some plowing experience, you can determine how much spring tension is required to fit your plowing requirements.

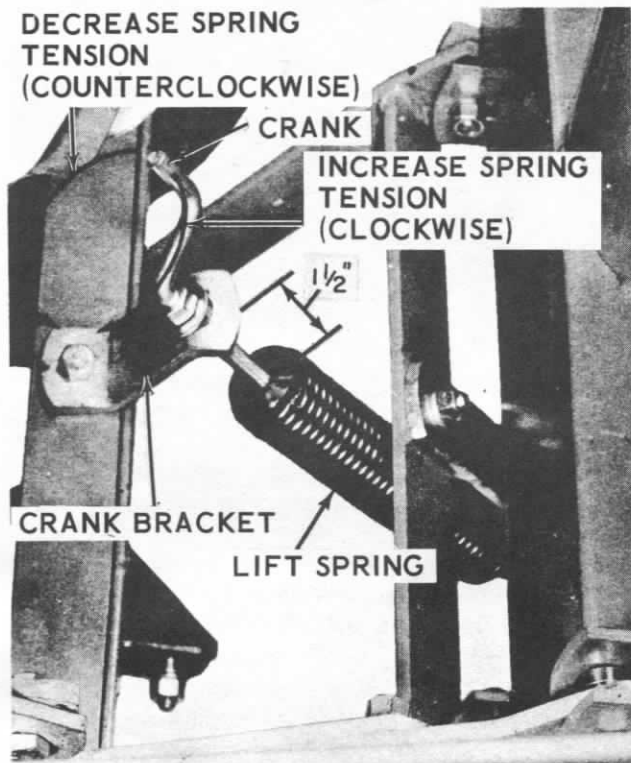

Figure2

1. Raise blower up into transport position by moving lift handle to the rear position.
2. Turn spring crank clockwise until top of spring is 1-1/2" from top of crank bracket.

Deflector (See Figure 1)

The deflector mounted on top of elbow determines the distance snow is thrown. By moving top of deflector down decreases distance of throw and raising deflector increases distance of throw. Operator must get off the tractor to make this adjustment. Disengage auger clutch and stop engine before making this adjustment.

Skid Shoe Adjustment

The skid shoe mounted on each side of auger housing adjusts the distance the scraper blade is raised above the plowing surface. Removing snow from a gravel driveway or an uneven surface, it is advisable to keep scraper blade as high above the surface as possible



Figure 3

to prevent possible damage to auger. On black top or concrete surface, keep scraper blade as close to the surface as possible. Skid shoes can be adjusted so that scraper blade will rest directly on the surface by turning skid shoes around so that flange on bottom of skid shoes extends beyond auger housing. This is advisable on an extremely smooth surface only. (See Figures 3 and 4.)

To Adjust Skid Shoes (See Figure 5)

Raise blower a few inches off the ground and loosen 6 nuts securing skid shoes to auger housing (3 nuts on each side). Move skid



Figure 4

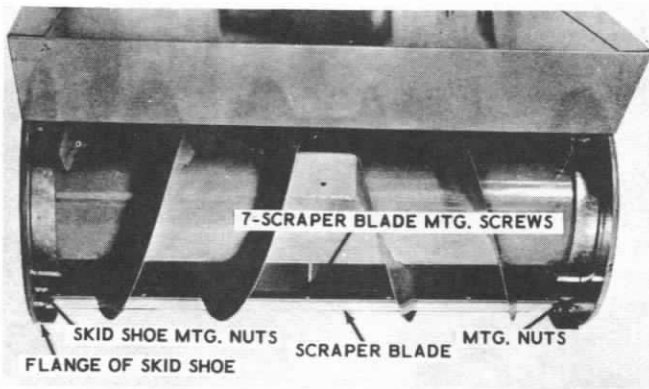

Figure 5

shoes up or down to desired position and tighten nuts securely. Adjust both skid shoes to the same height to keep auger level.

Elbow Drive Tube Adjustment (See Figure 6)

If elbow will not hold its position and tends to rotate, adjust lock nut on end of elbow drive tube eye bolt. Tighten lock nut 1/8 turn and check rotation of drive tube by turning elbow crank. A small amount of resistance should be encountered. If elbow still tends to rotate, repeat adjustment. Do not over tighten nut. Tighten until elbow holds its position.



Figure 6

Belt Adjustment

1. Initial Drive Belt (from engine). When properly tensioned, this belt will not deflect more than $3/8$ " under finger pressure midway between the pulleys. If adjustment is required, refer to paragraph 9 under "Mounting Blower on Tractor."
2. Secondary (Jackshaft) Drive Belt. This belt should be adjusted to have between $2-1/4$ " and $2-1/2$ " clearance between the upper and lower sections at the idler, Figure 22, when the clutch rod is engaged. The adjusting brackets, Figure 22, can be lengthened or shortened as necessary to adjust the belt.

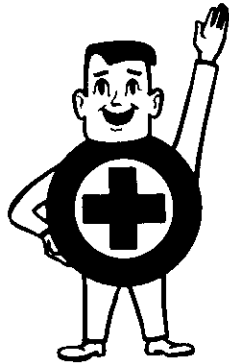

"YES, MR DEALER, IVE
STUDIED THE MANUAL"

SAFETY SUGGESTIONS



Training

1. Regard your snow blower as a piece of power equipment and be sure this is understood by all who operate it.
2. Never allow children or young teen-agers to operate the tractor and snow blower.
3. Be sure you know how to stop the tractor and auger at a moment's notice.
4. Instruct children to keep away from the area of operation at all times.

Preparation

1. Check the tractor and blower to make certain both are in good operating condition.
2. Fill gas tank out of doors and avoid spilling gasoline over engine. Do not fill tank with gasoline while smoking or while engine is running.
3. Do not remove any guards or covers while operating tractor and blower.

Operation

1. Give complete and undivided attention to the job at hand.
2. Keep the area clear of all persons, particularly small children.
3. Stop engine when tractor is unattended.
4. Disengage auger clutch when someone approaches.
5. Do not allow anyone other than the operator to ride on the tractor or to be towed behind.
6. Extreme caution should be exercised under slippery conditions. Reduce forward speed. Install tire chains to traction wheels for added safety.
7. Do not attempt to clear auger or discharge elbow while engine is running.
8. When changing position of the deflector, disengage the auger clutch.
9. Never direct snow discharge at people or buildings.
10. Disengage auger clutch when transporting.

Maintenance and Storage

1. Follow implicitly the manufacturer's recommendations for maintenance.
2. Have a competent service man make thorough inspection of the snow blower before the snow season begins.
3. Store gasoline in a safe container. Store container in a cool, dry place, not in the house or near heating appliances.
4. Keep the snow blower, tractor and gas container in locked storage to prevent children from playing and tampering with them.
5. Maximum snow removal results and safety can only be expected if the snow blower is maintained and operated correctly.
6. Gasoline powered equipment or fuel containers should not be stored in basement or in any closed area where heating appliances or open pilot lights are present, unless fuel is completely drained from power equipment or fuel containers.

OPERATING SUGGESTIONS

Preparing for Snow Removal

CAUTION

Disengage auger clutch when starting engine and when transporting auger.

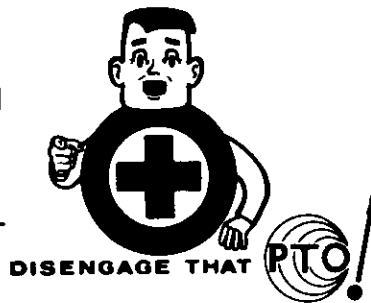

Before the first snowfall, the area in which snow removal is to take place should be cleared of all stones, sticks, etc., which might be picked up by the auger. Any obstacles should be marked to prevent tractor and blower from being driven into them.

To become familiar with the controls, operate the tractor and snow blower in a clear area before removing snow. The more familiar you become with the snow blower, the better results you will have in its use.

A light coat of wax applied to the inside surfaces of auger housing prevents snow and ice from sticking to it. The inside of elbow and deflector should be waxed several times during the snow removal season.

Allow ample engine warm up time before starting snow removal.

Best results are obtained when snow is removed as soon as possible after it falls.

OPERATION

The snow blower controls are conveniently located at the operator's position on the tractor. By engaging the auger clutch, snow is thrown through elbow by the motion of the auger. Turning elbow crank directs snow discharge and deflector controls distance snow is thrown.

Snow Conditions

Snow removal conditions vary so greatly from the first light fluffy snowfall to the wet heavy snow that operating instructions must be flexible to fit snow removal encountered. The operator must adapt the tractor and snow blower to depth of snow, wind direction, temperature, and surface conditions.

Operating Speed

The auger speed is directly related to engine speed. For maximum snow removal and discharge, maintain high engine RPM (three-quarters to full governed throttle). Always operate the tractor in low range for safe and efficient snow removal. The speed control lever should be adjusted to provide a ground speed most compatible with the snow removal conditions.

In deep, drifted, or banked snow, it will be necessary to use full governed throttle and very slow low range ground speed. Drive the auger into the snow, disengage tractor clutch and allow blower to clear the snow. Repeat this method until a path is cleared. On the second pass, overlap the first enough to allow the blower to handle the snow without repeatedly stopping the tractor.

In extremely deep snow, raise auger from the ground, drive tractor ahead in the deep snow to remove top layers first. Disengage tractor clutch and allow auger to clear itself. Reverse tractor and lower auger to the ground. Drive tractor ahead and repeat process to remove balance of snow. Working with repeated passes into and out of drifts will eventually move even the deepest of snow piles.

Operating Tips

1. Whenever possible, discharge snow down wind.
2. Do not attempt to remove ice or hard packed frozen snow.
3. Always overlap each pass slightly to assure complete snow removal.
4. A frozen or stuck auger or elbow must be broken loose or thawed with care.

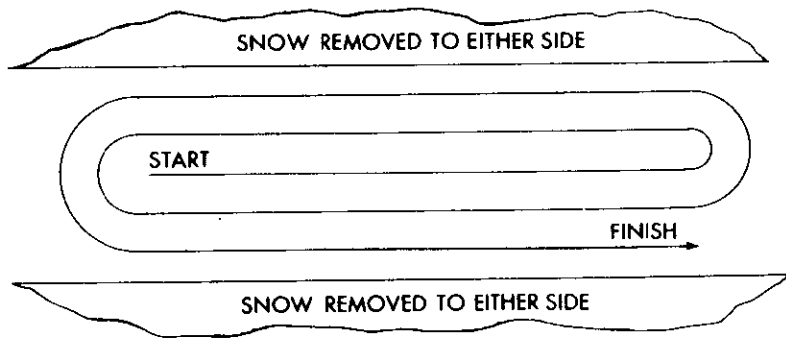

Figure 7

METHODS (See Figures 7 and 8)

A definite pattern of operation is required to thoroughly clean the snow area. This pattern will avoid a second removal of snow and avoid throwing snow in unwanted places. Where it is possible to throw snow to right and left, as on a long driveway, it is advantageous to start in the middle. Plow from one end to the opposite end throwing snow to both sides without changing direction of discharge elbow. If snow can only be thrown to one side of the driveway or sidewalk, start on the opposite side. At the end of each pass, rotate elbow 180° for the return pass. At the end of each succeeding pass, rotate chute 180° to maintain direction of throw into the same area.

USE OF TIRE CHAINS

The use of tire chains is optional with the operator. The extra traction with tire chains gives the tractor operator maneuverability in handling heavy snow removal jobs. Tire chains are sold as accessories by your dealer and are not included with the blower.

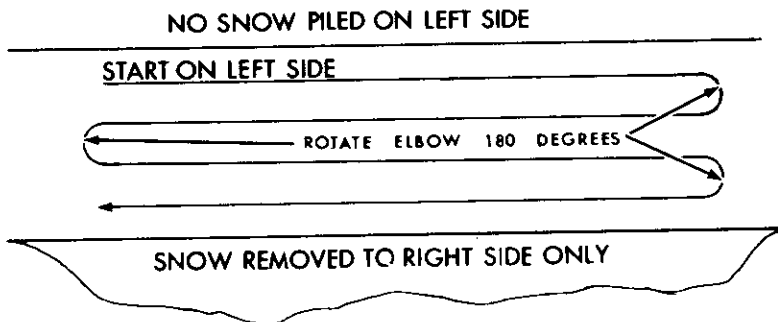

Figure 8



CHAIN AND CABLE LUBRICANT

Penetrating lubricant and rust preventive for all chains and cables.

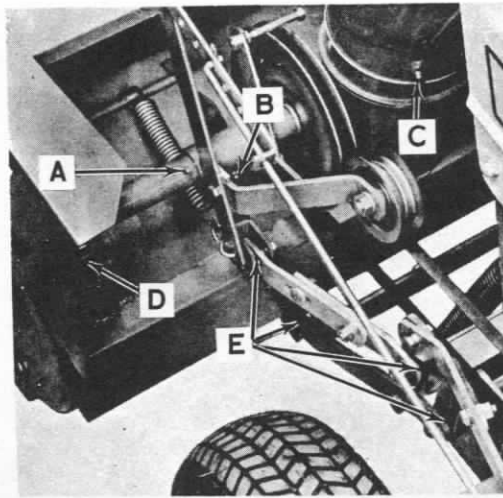

Figure 9

MAINTENANCE

Lubrication (See Figure 9)

Lubrication points A through C are lubricated through grease fitting. Lubricate these points before each operating season and as required during the season with a good grade of pressure gun grease.

- A. Jackshaft Housing
- B. Idler Bracket
- C. Elbow Collar

D. Auger drive chain: Lubricate chain every 40 operating hours with Case heavy duty Chain and Cable Lubricant (Figure 9) available through your Case Compact Tractor dealer. It is important that oil reaches inside each roller. Wipe off excess oil from chain.

E. Pivot and friction points: To maintain smooth and free operation, apply a few drops of No. 30 oil as required to all pivot and friction points. (Figure 9 shows a few points to be lubricated.)

The auger and idler pulley bearings are self-lubricating and no additional lubrication is required.

Blower Drive Belt Adjustment (See Figure 22)

Periodically check blower drive belts to insure that they are properly adjusted. It is important to maintain proper belt adjustment to obtain maximum belt life. Belt adjustments are covered on page 8.

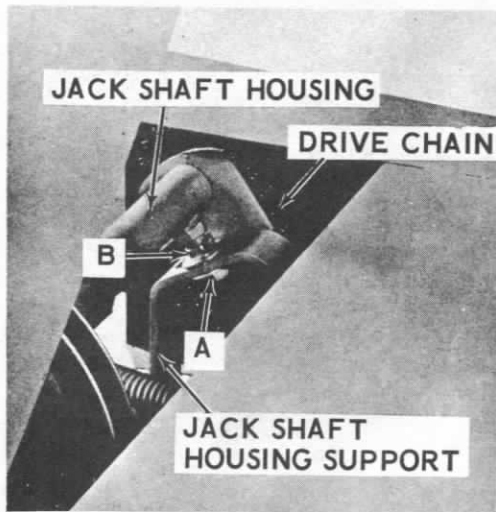

CASE EQUIPMENT ENAMEL

Keep the original finish and color on all CASE equipment.

Figure 10

If initial drive belt is stretched beyond adjusting slots in guide arms, replace with a new belt of the type specified in parts list.

Auger Drive Chain Adjustment (See Figure 10)

Excessive slack in auger drive chain due to normal chain stretch can be removed by adjusting jackshaft housing nuts.

To Adjust Auger Chain

1. Disengage auger clutch and loosen the two lower mounting nuts (A) 2 or 3 complete turns.
2. Tighten the two upper mounting nuts (B) to tighten chain. Make certain nuts (B) are turned the same amount to keep jackshaft housing parallel with auger housing.

CAUTION

Do not over tighten chain. A correctly adjusted chain will have a slight amount of slack. Overtightening will result in early failure of the chain.

3. Tighten lower nuts (A) to secure chain adjustment. Check chain clearance so as not to strike auger housing. Test chain and repeat adjustment if necessary until all excess slack is removed.

Scraper Blade and Skid Shoes (See Figure 5)

Both the scraper blade and skid shoes are subject to wear and are designed to be readily replaceable. Replace before wear is excessive so as not to damage the auger housing.

REMOVING AUGER FROM TRACTOR

1. Locate tractor with blower as close as possible to the place where the blower will be stored.
2. With blower in transport position, loosen gear box mounting and remove with clutch rod. Remove drive belts from engine pulley and gear box pulleys. Turn lift spring counterclockwise until crank is almost turned out of spring.
3. Lower the blower to operating position. Remove the bolt from lift arm.
4. Remove the two lift assembly mounting screws from lift pivot bracket. Disengage pivot bar from notches in lift pivot bracket and move tractor away from blower. Reinstall mounting screws in lift pivot bracket and remove pivot bracket front mounting plate of tractor.
5. Remove the lift pivot bracket and brace.

To prevent hardware and small parts from being lost, place them in a bag or like container and attach to auger.

STORING SNOW BLOWER

At the end of the snow season, the following steps are recommended:

1. Remove snow blower assembly from tractor.
2. Wash off any salt deposit which may have dried on the auger and housing. Paint or cover exposed metal with a light coat of oil. Case Touch-up Enamel is available through your Case Compact Tractor dealer. See Figure 10.
3. Service the blower following lubrication instructions on page 13. Auger drive chain must be oiled thoroughly using Case Chain and Cable Lubricant to prevent rust from forming.
4. Store snow blower in a dry place.

MOUNTING SNOW BLOWER ON TRACTOR

Before the snow removal season begins, it is advisable to check blower completely to insure it is in good operating condition.

1. Mount lift pivot bracket and braces to front mounting plate on tractor and remove lift assembly mounting screws from lift pivot bracket (See Figure 21.)

15 START
READING
HERE

2. Align rear of blower lift assembly with lift pivot bracket. Engage pivot bar in notches near bottom of lift pivot bracket. Lift arm must slide between front wheels and under tractor. (See Figure 21).
3. Pivot lift assembly back until holes in lift assembly line up with holes in lift pivot bracket. Insert mounting screw through holes and tighten securely into lift pivot bracket (See Figure 21.)
4. Connect lift arm to lift lever. (See Figure 21.)
5. Install gear box, clutch rod, and drive belt. See diagrams 8 and 9 under "Mounting Blower on Tractor."
6. With secondary drive belt positioned around blower drive pulley, push idler arm forward as far as possible and place drive belt around gear box pulley. Allow idler arm to move back until hook on clutch rod engages clutch arm.
7. Check belt adjustment. Refer to setting up instructions "Blower Drive Belt Adjustment" instructions.
8. Raise blower into transport position and adjust auger lift spring to desired tension. (See Figure 2.)
9. Before operating the snow blower, review the adjustment and maintenance instructions.

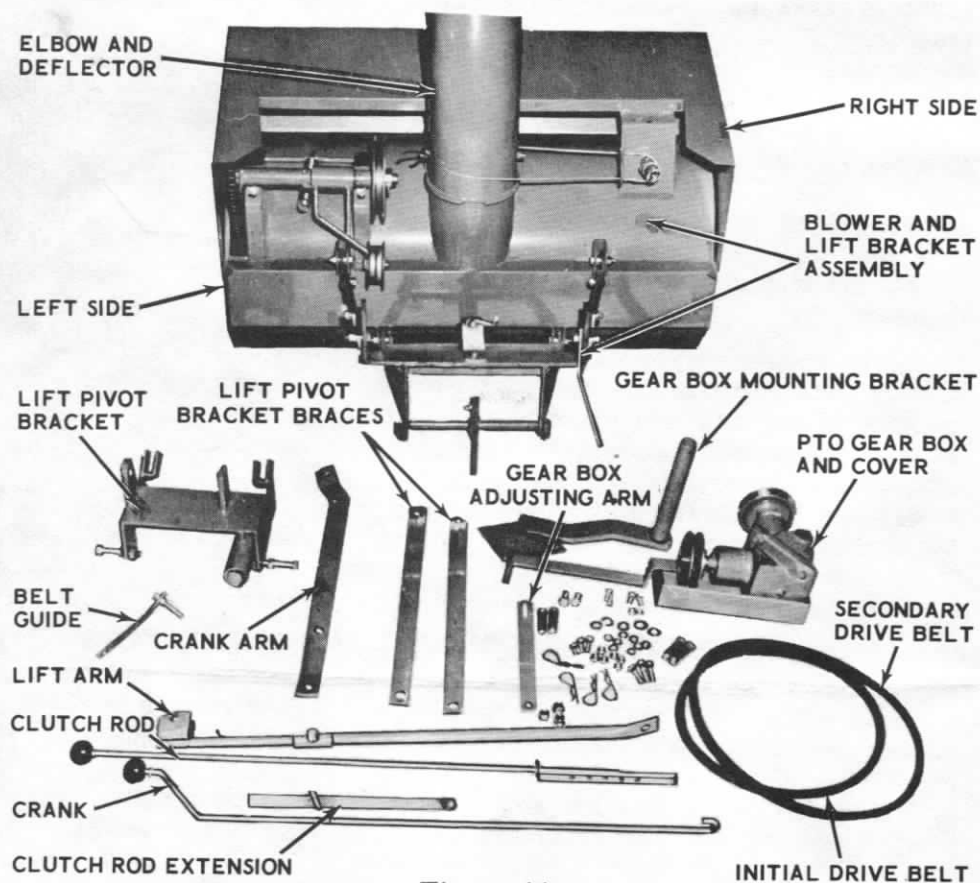

Figure 11

SET-UP INSTRUCTIONS

Unpacking

The snow auger and all necessary parts and hardware are packed in one carton. Unpack carton carefully to insure all parts are removed. Remove screw and lock nut fastening clutch and crank arms together. Save screw and lock nut to be used later for attaching clutch arm. Lay parts out and assemble as follows: (See Figure 11).

Blower Preassembly

It is suggested to read the setting up instructions before assembling and attaching auger to tractor. This will help to familiarize yourself with the auger and parts.

Before assembling blower, remove spring tension from lift assembly as follows: (See Figures 12 and 13.)

1. After removing auger housing from carton, position housing with lift assembly facing up.
2. Stand in front of auger housing. With your left hand, pull top of lift assembly down and toward you. With your right hand, unhook clutch spring from auger housing.
3. After unhooking clutch spring, allow lift assembly to move away from you until spring tension is released. Remove clutch spring and place in bag of parts until time of installation.
4. With auger in the same position (lift assembly facing up), slide lift tube arm next to lift bracket.
5. Align hole in lift tube arm with hole in lift bracket. Insert $3/8$ " x 1" screw through holes and fasten securely with lock nut.

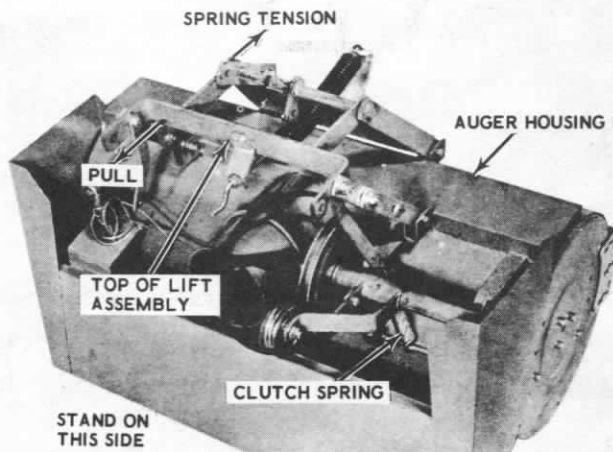

Figure 12

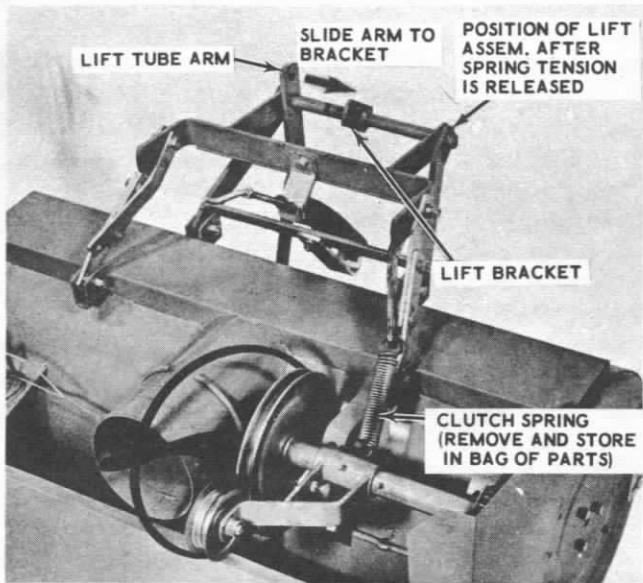

Figure 13

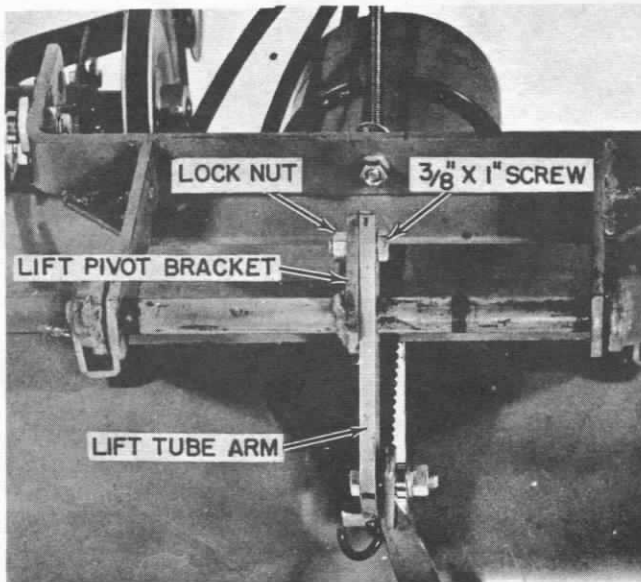

Figure 14

6. Place the elbow crank through the guide on the crank arm and connect to the eye bolt (Figure 17) on the rear right side of the blower housing. Press the plastic bushing into the crank guide.
7. Secure the crank arm and crank arm brace to the upper lift bracket (Figure 17) with two 3/8" x 1" cap screws, lockwashers, and hex nuts. Tighten the lower cap screw on the crank arm brace which was preassembled to the upper lift bracket.
8. Secure the idler arm (Figure 18) to idler bracket with the 5/16" x 3/4" cap screw and lock nut. Be sure the square guide on the idler arm is resting evenly on the idler bracket before tightening the lock nut.
9. Position front of elbow toward rear of auger housing and slip elbow over auger collar. See Figure 15. Holding bracket must go through slot in ring. Rotate elbow 180° (front facing forward), make certain holding bracket slips over ring.
10. Loosen screw on left side of elbow collar. Remove tape from around elbow drive cable and make certain both ends of cable are through cable guide. The end of cable that comes off front of drive tube goes around front of elbow collar and remaining end goes around rear. See Figure 16.
11. On left side of elbow, thread ends of cable between special washer and flat washer. Make certain cable is not tangled on drive tube. Pull ends of cable until all slack is removed from cable. Do not pull cable too tight, just enough to remove the slack. Tighten screw on left side of elbow to lock cable to elbow.

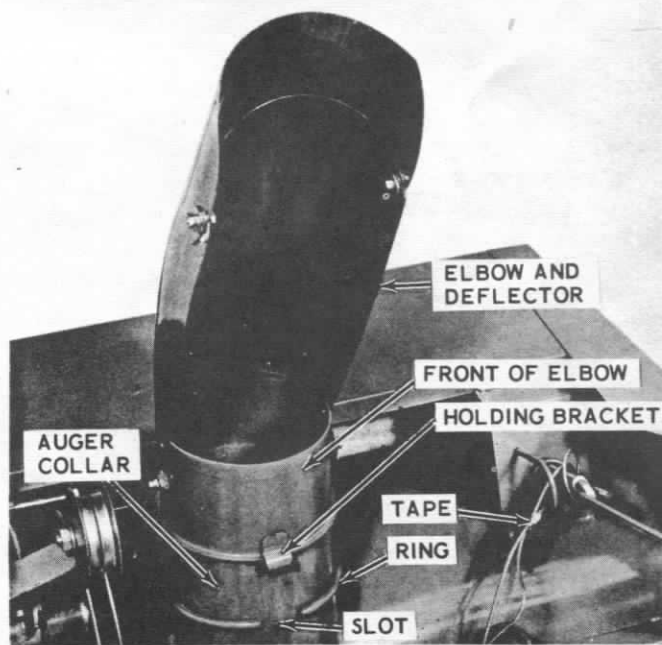

Figure 15

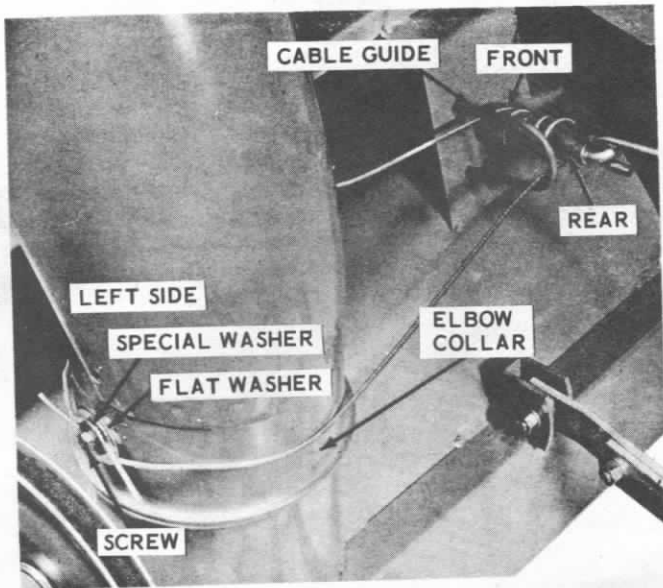

Figure 16

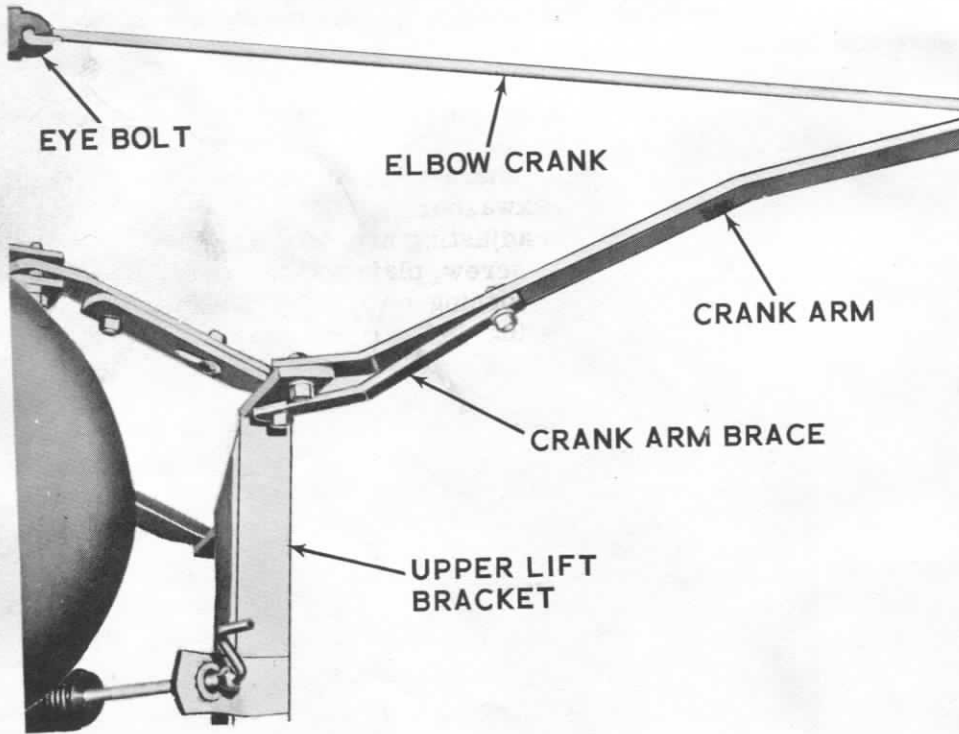

Figure 17

Mounting Blower on Tractor

1. Preassemble the two (2) stabilizer bars, Figure 21, to the lift pivot bracket using two pivot bushings, 3/8" x 1-1/2" cap screws, lockwashers, and hex nuts. Position the pivot bushings between the lugs on the pivot bracket before inserting the cap screws.
2. Attach the lift pivot bracket to the front mounting lugs on the tractor using two 5/8" pins and retainers.
3. Connect the stabilizer bars, Figure 21, to the holes in the tractor frame under the engine pad using two (2) 5/8" pins and retainers.

NOTE

The right hand stabilizer bar mounts on the inside of the tractor frame. The left hand stabilizer bar mounts on the outside of the tractor frame.

4. Connect the gear box mounting bracket, Figure 19, to the tube on the lift pivot bracket.
5. Position the gear box on the mounting bracket and bolt snugly with two (2) 3/8" N. F. x 3/4" cap screws, plain washers, and lockwashers.
6. With gear box cover bolts loose, place the shorter drive belt carefully around the fan and on to the engine pulley. Connect the belt to the input pulley on the gear box.
7. Loosen the generator mounting bolts, removing the lower bolt on the front generator mounting flange. See Figure 20. Secure the gear box adjusting arm to the generator mounting using the original 5/16" x 3/4" cap screw and lockwasher.
8. Bolt the slotted end of the adjusting arm loosely to the gear box cover with a 5/16" x 3/4" cap screw, plain washer and lockwasher.
9. Tension the drive belt by forcing on the gear box outward and using the inside front mounting bolt on the gear box (tightened snugly) as a fulcrum point, pull outward on the clutch rod guide.

NOTE

When properly tensioned, the belt should not deflect more than 3/8" under finger pressure midway between the pulleys.

10. Remove the two 1/2" x 2-3/4" cap screws from the lift pivot bracket. Position the blower assembly in front of the tractor and place the lower lift bracket into the notches on the lift pivot bracket.

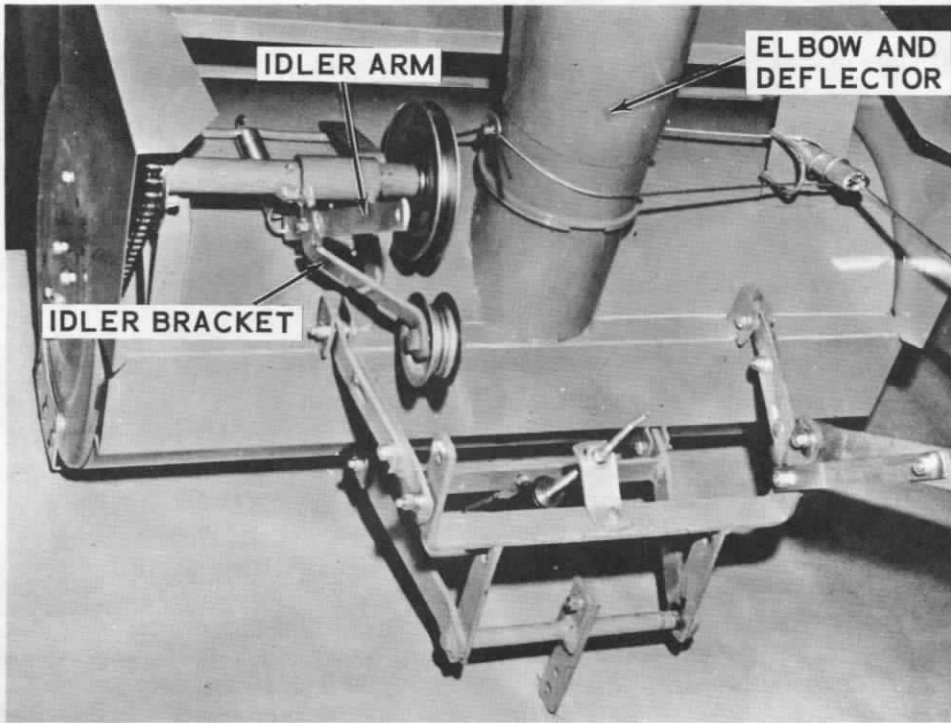

Figure 18

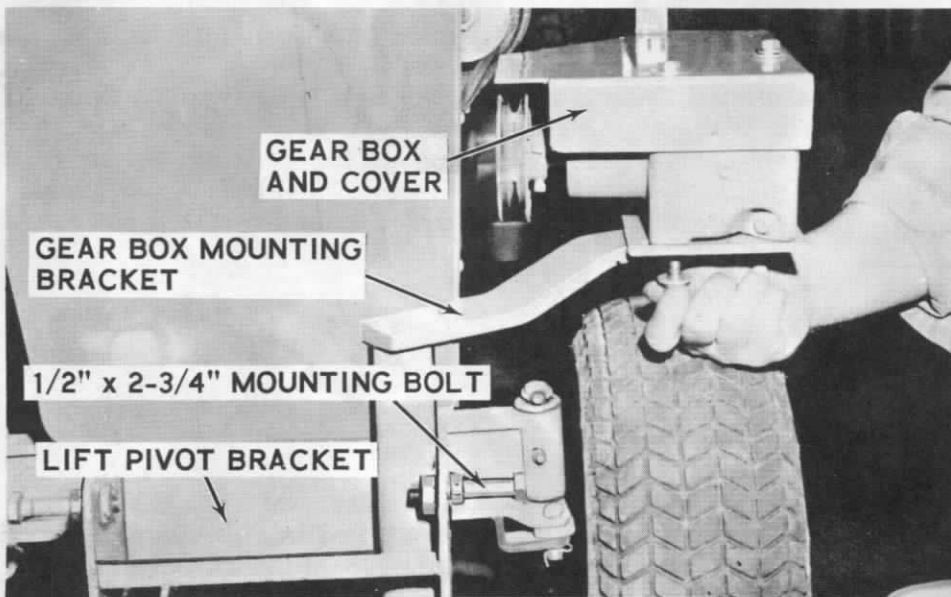

Figure 19

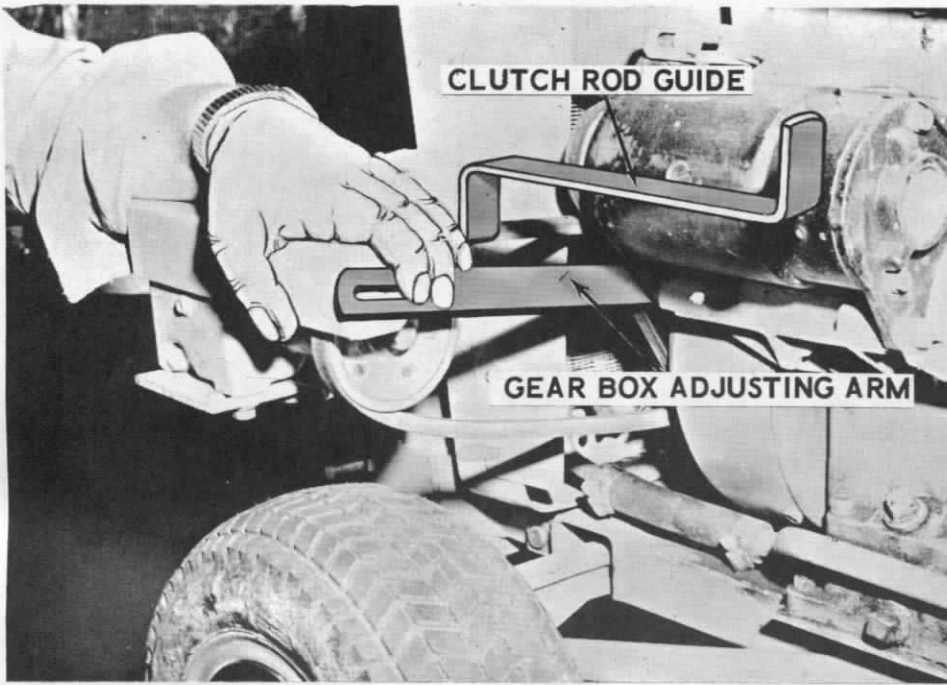

Figure 20

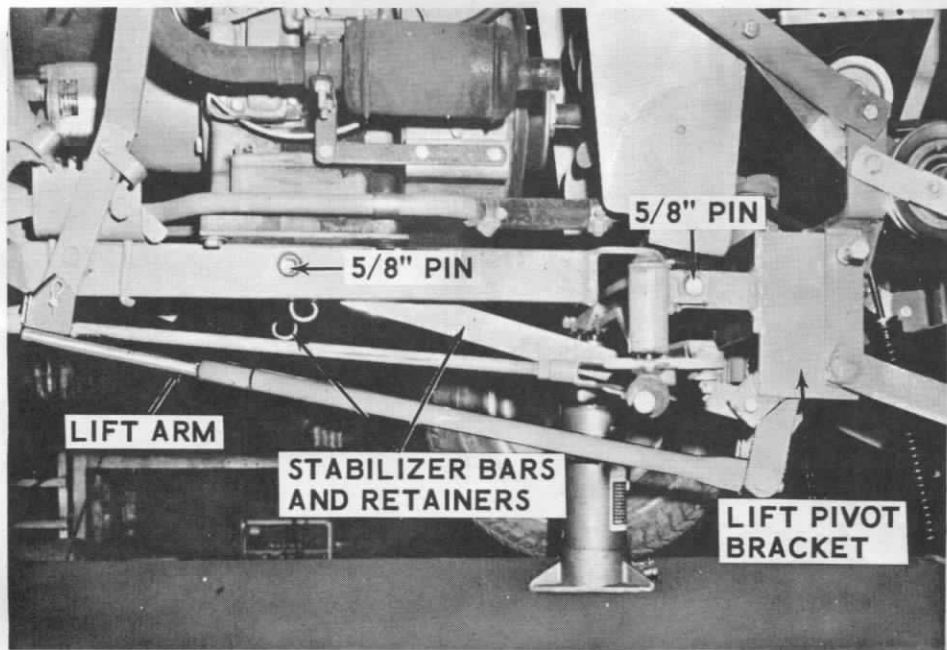

Figure 21

NOTE

The snow blower will be easier to assemble to the lift pivot bracket if the tractor front wheels are raised about 4" from the floor.

11. Align the lift bracket with the holes in the lift pivot bracket and replace the 1/2" x 2-3/4" cap screws. Tighten the double hex nuts securely.
12. Place clutch rod through the guide arm on the gear box cover and bolt snugly to the idler arm, Figure 22, with a 5/16" x 3/4" cap screw and lock nut.
13. Push clutch rod ahead and engage the catch. Connect the clutch spring to the bottom of the idler arm.
14. Install the secondary drive belt as shown in Figure 22.
15. Install the belt guide, Figure 22, to the top hole on the left side of the lift bracket with a 3/8" x 1" cap screw, plain washer, lockwasher, and nut. Adjust the guide so it clears the belt approximately 1/8" when clutch is engaged.
16. Connect the lift arm, Figure 21, to the tractor lift lever using a 3/8" x 1-1/2" cap screw, pivot bushing, lockwasher, and nut. Connect the clevis end of the lift arm to the lower lug on the blower lift bracket with a 3/8" pin and retainer.
17. Refer to paragraph 2 under "Belt Adjustment" on Page 8.
18. Adjust the lift spring. See Figure 2. Review the operating, adjustment, and maintenance instructions with the operator.

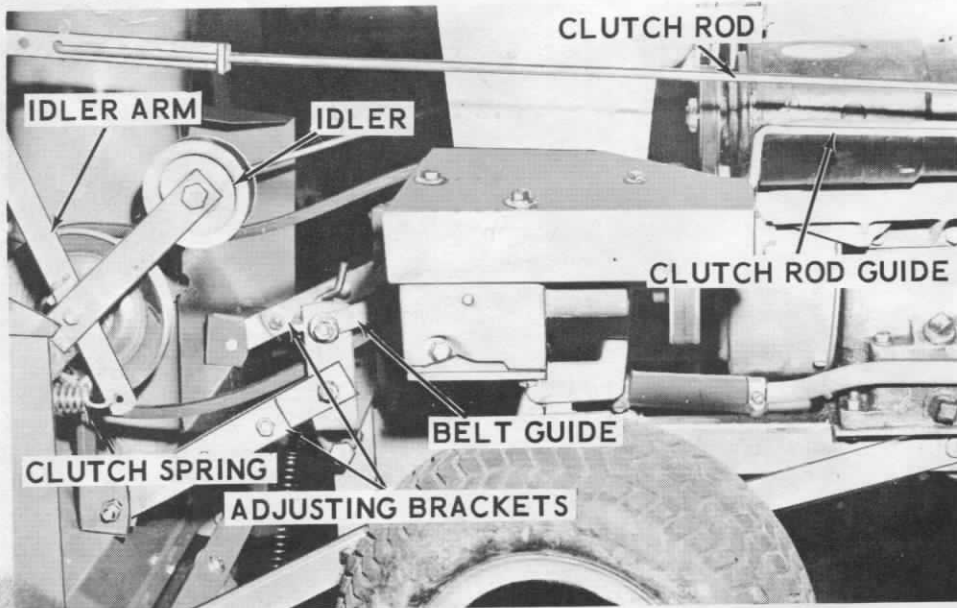

Figure 22

TABLE OF CONTENTS

FORWARD	1
BEFORE PLACING BLOWER IN OPERATION	3
BLOWER OPERATING CONTROLS AND ADJUSTMENTS	3
Clutch Rod	3
To Start	4
To Stop	4
Elbow Crank	4
Tractor Implement Lift Lever	4
OPERATING ADJUSTMENTS	4
Lift Spring Adjustment	4
Deflector	5
Skid Shoe Adjustment	5
To Adjust Skid Shoes	6
Elbow Drive Tube Adjustment	7
Belt Adjustment	8
SAFETY SUGGESTIONS	9
OPERATING SUGGESTIONS	10
METHODS	12
USE OF TIRE CHAINS	12
MAINTENANCE	13
Lubrication	13
Blower Drive Belt Adjustment	13
Auger Drive Chain Adjustment	14
To Adjust Auger Chain	14
Scraper Blade and Skid Shoes	15
REMOVING AUGER FROM TRACTOR	15
STORING SNOW BLOWER	15
MOUNTING SNOW BLOWER ON TRACTOR	15
SET-UP INSTRUCTIONS	17
Unpacking	17
Blower Preassembly	17
Mounting Blower on Tractor	21



Win. Form 9- 35162

PRICE 25 CENTS

LCNBE

PRINTED
IN
U.S.A.