



BLUE VALLEY TRACTOR & SUPPLY
 20219 Metcalf Ave.
 P. O. Box 219
 Stilwell, KS 66085
 DARWIN BAKER, Owner (913) 681-8088

SNOW CASTER

N80, N84

Operator's Manual 9-51940

L54 or L84

Winter HD 20W
 Summer HD 30W

Serial 16365

Model 446-79

Belt # 53539

Bill

casecollecting@ersoll.com

JI Case
 A Tenneco Company





This Safety Alert Symbol Indicates Important Safety Messages In This Manual When You See This Symbol Carefully Read The Message That Follows and Be Alert To The Possibility Of Personal Injury Or Death

IF THIS MACHINE IS USED BY AN EMPLOYEE OR IS LOANED OR RENTED, MAKE ABSOLUTELY CERTAIN THAT THE OPERATOR(S), PRIOR TO OPERATING:

1. IS INSTRUCTED IN SAFE AND PROPER USE.
2. REVIEWS AND UNDERSTANDS THE MANUAL(S) PERTAINING TO THE MACHINE.

751253



WARNING

BEFORE STARTING ENGINE

STUDY OPERATOR'S MANUAL SAFETY MESSAGES
READ ALL SAFETY SIGNS ON MACHINE
CLEAR THE AREA OF OTHER PERSONS

LEARN & PRACTICE SAFE USE OF CONTROLS BEFORE OPERATING

IT IS YOUR RESPONSIBILITY TO UNDERSTAND AND FOLLOW MANUFACTURER'S INSTRUCTIONS ON MACHINE OPERATION, SERVICE, AND TO OBSERVE PERTINENT LAWS AND REGULATIONS. OPERATOR AND SERVICE MANUALS MAY BE OBTAINED FROM YOUR EQUIPMENT DEALER.

SAFETY MESSAGES



IMPORTANT: The safety messages contained in this manual are to be used together with the Safety Messages appearing in the tractor operator's manual. Be sure to review both carefully before operating the tractor snow caster combination.



CAUTION: Regard your snow caster as a piece of power equipment and be sure this is understood by all who operate it.



CAUTION: Keep the area of operation clear of all persons particularly small children.



CAUTION: Never allow children or young teenagers to operate the tractor and snow caster.



CAUTION: Stop engine and disengage attachment drive clutch when tractor is unattended.



CAUTION: Be sure you know how to stop the tractor and engage at a moment's notice.



CAUTION: Give complete and undivided attention to the job at hand.



CAUTION: Check the tractor and caster to make certain both are in good operating condition.



CAUTION: Disengage attachment drive clutch when someone approaches.



CAUTION: Fill gas tank out of doors and avoid spilling gasoline. Do not fill tank with gasoline while smoking or while engine is running.



CAUTION: Extreme caution should be exercised under slippery conditions. Reduce forward speed. Install tire chains and wheel weights to traction wheels for added safety.



WARNING: Contact by any part of the body with the rotating snow caster auger can result in serious injury.

Extra care should be used around exposed areas such as the auger and discharge chute.

- ALWAYS:**
1. Disengage the attachment drive clutch,
 2. shut off tractor engine,
 3. set parking brake, and
 4. wait for all motion to stop.
- BEFORE** approaching or allowing anyone else to approach the front of the tractor to:
1. clear the auger or discharge chute,
 2. change position of chute deflector,
 3. service or adjust snow caster or tractor, or
 4. for any other reason.



CAUTION: Never direct snow discharge at people or buildings.



CAUTION: Disengage attachment drive clutch when transporting.



CAUTION: Disengage the attachment drive clutch when starting engine and when transporting the snow caster. Before the first snowfall, the area in which snow removal is to take place should be cleared of all stones, sticks, etc., which might be picked up by the snow caster. **OBSTACLES SUCH AS DRIVEWAY MARKERS, WATER OR GAS SHUT OFFS, ETC. SHOULD BE MARKED SO THEIR LOCATIONS UNDER THE SNOW ARE VERY OBVIOUS.**



CAUTION: Do not allow anyone other than the operator to ride on the tractor or to be towed behind.

IMPORTANT: Always install new decals whenever the old decals are destroyed, lost, painted over or illegible. When individual parts are replaced that have decals attached, be sure to install a new decal with the new part. Replacement decals are available from your Case Dealer.

TABLE OF CONTENTS

| | |
|-------------------------------------|-------|
| Safety Messages | 3 - 4 |
| Introduction | 6 |
| Application Chart | 6 |
| Preparing for Snow Removal | 7 |
| Methods of Snow Removal | 7 |
| Snow Conditions | 7 |
| Operating Procedure | 8 |
| Operating Controls | 8 |
| Tire Chains and Wheel Weights | 8 |
| Adjustments | 9-10 |
| Assembly | 11 |
| Installation | 12 |
| Removing the Snow Caster | 13 |
| Maintenance | 14 |

casecoltingersoll.com

INTRODUCTION

This Operator's Manual is for the Models N-80 and N-84 Snow Caster. This Operator's Manual includes:

- (a) Safety Rules
- (b) Installation Procedure
- (c) Operating Procedure
- (d) Adjustments
- (e) Maintenance

Read this manual before operating your snow caster. See your J I Case dealer for parts or repairs.

The words "Right", "Left", "Front", and "Rear" as used in this manual indicate directions when you are in the operator's seat in the normal operating position.

NOTE: The J I Case Company reserves the right to make improvements in design or changes in specifications at any time without incurring any obligation to install them on units previously sold.

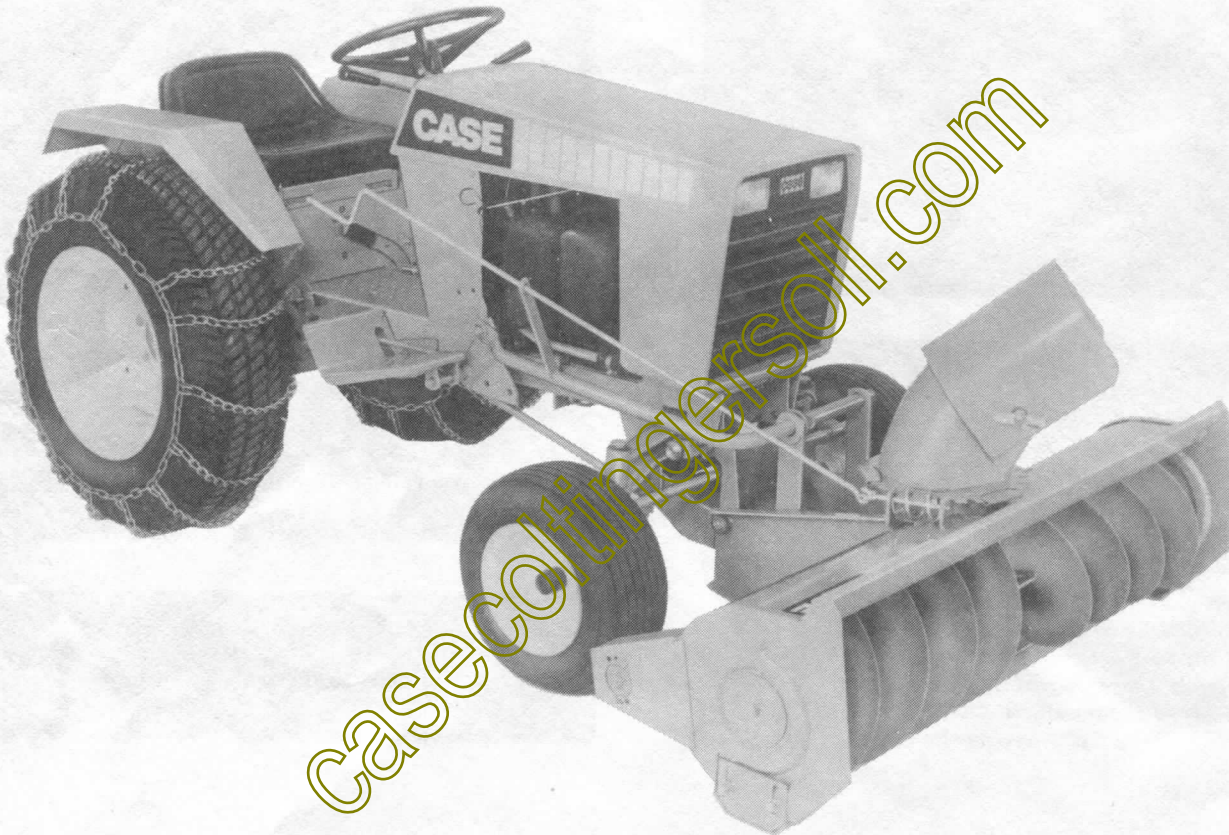

FIGURE 1 Model 446 Tractor with N84 Snow Caster, L11 Rear Weight Kit and E-16 Tire Chains

ATTACHMENT APPLICATION CHART

| MODEL | SIZE | TRACTOR MODEL (Beginning with PIN 9646800) |
|-------|---------------|---|
| N-80 | 38" (965 mm) | 210, 220, 222, 224 |
| N-84 | 48" (1220 mm) | 222, 224, 442, 444, 446, 448 |

PREPARING FOR SNOW REMOVAL

To become familiar with the controls, operate the tractor and snow caster in a clear area before removing snow. The more familiar you become with the snow caster the better results you will have in its use.

A light coat of wax applied to the inside surfaces of the discharge chute and deflector will help to prevent snow and slush from sticking. The inside of chute and deflector should be waxed several times during the snow removal season. Use any good commercial grade of paste wax or spray silicone which is available from your dealer or from your local hardware store.

Allow ample engine warm up time before starting snow removal.

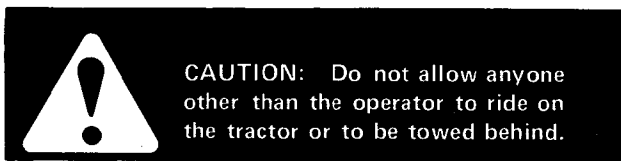

Best results are obtained when snow is removed as soon as possible after it falls.

Check each item covered in the "Adjustments" and "Maintenance" sections of this manual before operating the snow caster.

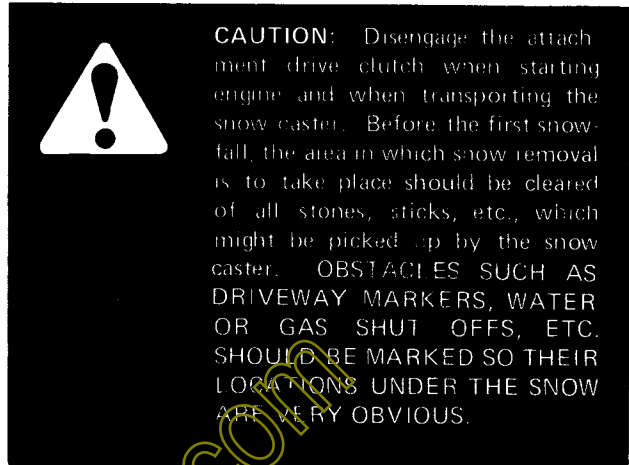

METHODS OF SNOW REMOVAL

A definite pattern of operation is required to thoroughly clean the snow area. This pattern will avoid a second removal of snow and avoid blowing snow to right and left, as on long driveway, it is advantageous to start in the middle. See Figure 2. Work from one end to the opposite end blowing snow to both sides without changing direction of discharge chute. If

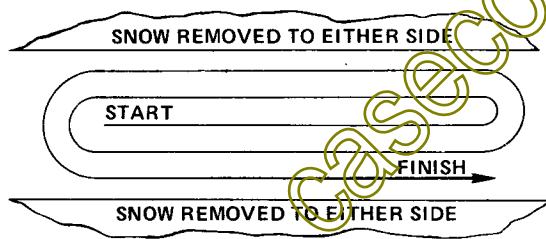

FIGURE 2

snow can only be blown to one side of the driveway, start on the opposite side. See Figure 3. At the end of each pass, rotate chute to opposite side for the return pass. At the end of each succeeding pass, rotate chute to opposite side to maintain direction of throw into the same area.

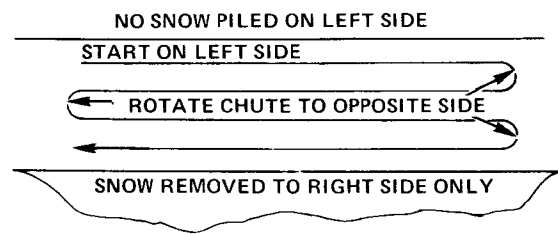

FIGURE 3

SNOW CONDITIONS

Snow removal conditions vary so greatly from the first light fluffy snowfall to wet or heavy snow that operating instructions must be flexible. The operator must operate according to depth of snow, wind direction, temperature, and surface conditions.

The auger speed and blowing distance are directly related to the engine speed. For maximum removal volume and distance, maintain high engine RPM (three-quarters to full governed throttle). Operating at lower throttle settings will increase fuel economy but reduce

the blowing distance. Always operate the tractor in low range for safe and efficient snow removal. The speed control lever should be operated to provide a ground speed most compatible with the snow removal conditions.

In extremely deep snow, raise snow caster into transport and remove top layer first. Lower the snow caster to the ground and repeat process to remove the balance of snow. Working with repeated passes into and out of drifts will eventually move even the deepest of snow piles.

OPERATING PROCEDURE

1. Whenever possible, discharge snow downwind.



2. Do not attempt to remove ice or hard packed frozen snow.
3. Always overlap each pass slightly to assure complete snow removal.
4. Use extreme care when freeing a frozen or stuck auger or chute. Always turn off the tractor first.
5. If tractor is equipped with Hydraulic Lift, operate with lift lever in the "float" (full forward) position. Never apply down pressure to the snow caster. With the hydraulic lift lever in the "float" position, the skid shoes will remain on the surface even though operating on uneven terrain.



WARNING: Contact by any part of the body with the rotating snow caster auger can result in serious injury.

Extra care should be used around exposed areas such as the auger and discharge chute.

ALWAYS:

1. Disengage the attachment drive clutch,
2. shut off tractor engine,
3. set parking brake, and
4. wait for all motion to stop.

BEFORE approaching or allowing anyone else to approach the front of the tractor to:

1. clear the auger or discharge chute,
2. change position of chute deflector,
3. service or adjust snow caster or tractor, or
4. for any other reason.

OPERATING CONTROLS

ATTACHMENT DRIVE CLUTCH

The snow caster is started and stopped with the attachment drive clutch lever.

See your tractor Operator's Manual for correct use of your tractor controls.

ATTACHMENT LIFT LEVER

The snow caster is raised and lowered with the attachment lift lever. Place the attachment lift lever in the "float" position when using the snow caster.

CRANK FOR THE DISCHARGE CHUTE

The discharge chute is rotated by turning the crank. This determines the direction of the discharged snow.

DEFLECTOR FOR THE DISCHARGE CHUTE

The deflector angle is changed by loosening the wing nuts and tilting it to the desired position and tightening the wing nuts. This controls the distance the snow is blown.

TIRE CHAINS AND WHEEL WEIGHTS

The use of tire chains and wheel weights, or rear weight box is recommended for snow removal operation. The extra traction resulting gives the tractor operator maneuverability in handling heavy snow removal jobs. These accessories are sold by your dealer and are not included with the snow caster.

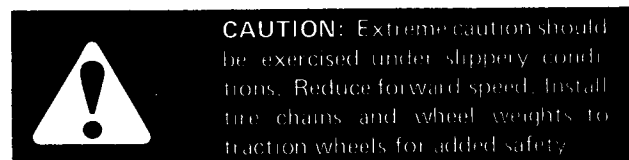

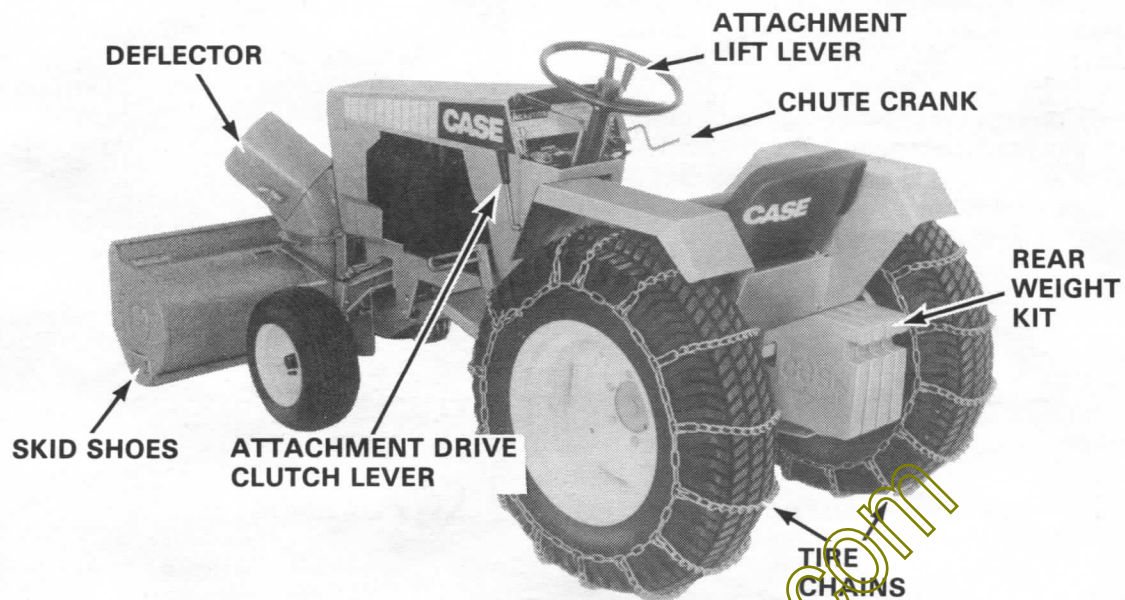

FIGURE 4 Model 446 Tractor with Model NS4 Snow Caster, L11 Rear Weight Kit and E18 Tire Chains

ADJUSTMENTS

SKID SHOES

The skid shoes have slotted mounting holes for adjustment. Use the following procedure to change the skid shoe height:

- (a) Raise the snow caster. Shut off the engine.
- (b) Place blocking under the snow caster cutting edge.
- (c) Place the hydraulic lift lever in the "float" position.
- (d) Loosen the bolts and raise or lower the skid shoes to the desired height.
- (e) Tighten the bolts.

Skid shoes raised: Snow caster cutting edge very close to surface. Use on smooth cement or asphalt surfaces.

Skid shoes lowered: Snow caster cutting edge raised above the surface. Use on uneven surfaces such as earth or gravel.

When the leading edges of the skid shoes wear, place the left skid shoe on the right side and the right skid shoe on the left side.

The skid shoes can be raised past the cutting edge by installing them with the offset to the outside. This will permit the cutting edge to be in contact with the ground surface. Use this method only when clearing hard level concrete or asphalt areas.

DEFLECTOR

The deflector has a slotted hole on each side for adjustment. To change the angle of the deflector, loosen the large wing nuts, tilt the deflector to the desired angle and tighten the large wing nuts.

Deflector tilted upward: Snow is cast higher and further from the tractor.

Deflector tilted downward: Snow is cast lower and closer to the tractor.

CUTTING EDGE

The cutting edge can be reversed when the leading edge wears down.

DRIVE CHAIN ADJUSTMENT

The chain has the proper tension when the lower strand has between 3/8" (10 mm) and 1/2" (12 mm) slack. Make this measurement when depressing the strand midway between the sprockets. Use "normal" finger pressure.

The chain will become progressively tighter by moving the bearing mounting bolts from holes "C" to holes "B" to holes "A". If the chain is too loose and the adjustment bolts are in holes "A", remove the special half link from the chain and move the adjustment bolts to holes "C".

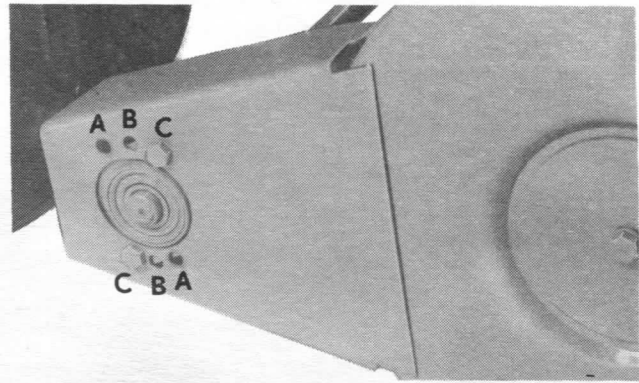

FIGURE 5 Chain Adjustment

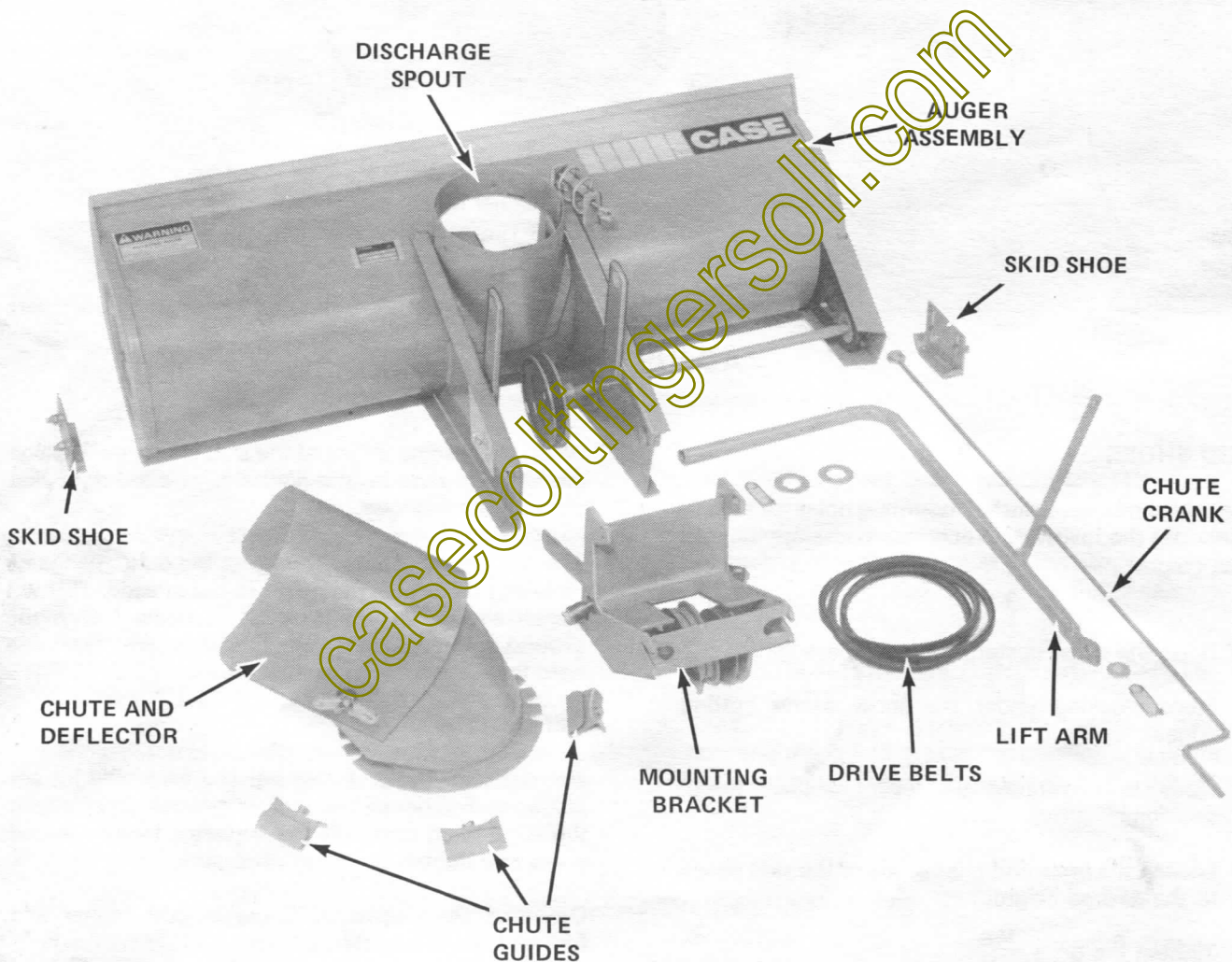

FIGURE 6 Model N84 Snow Caster (Disassembled)

ASSEMBLY

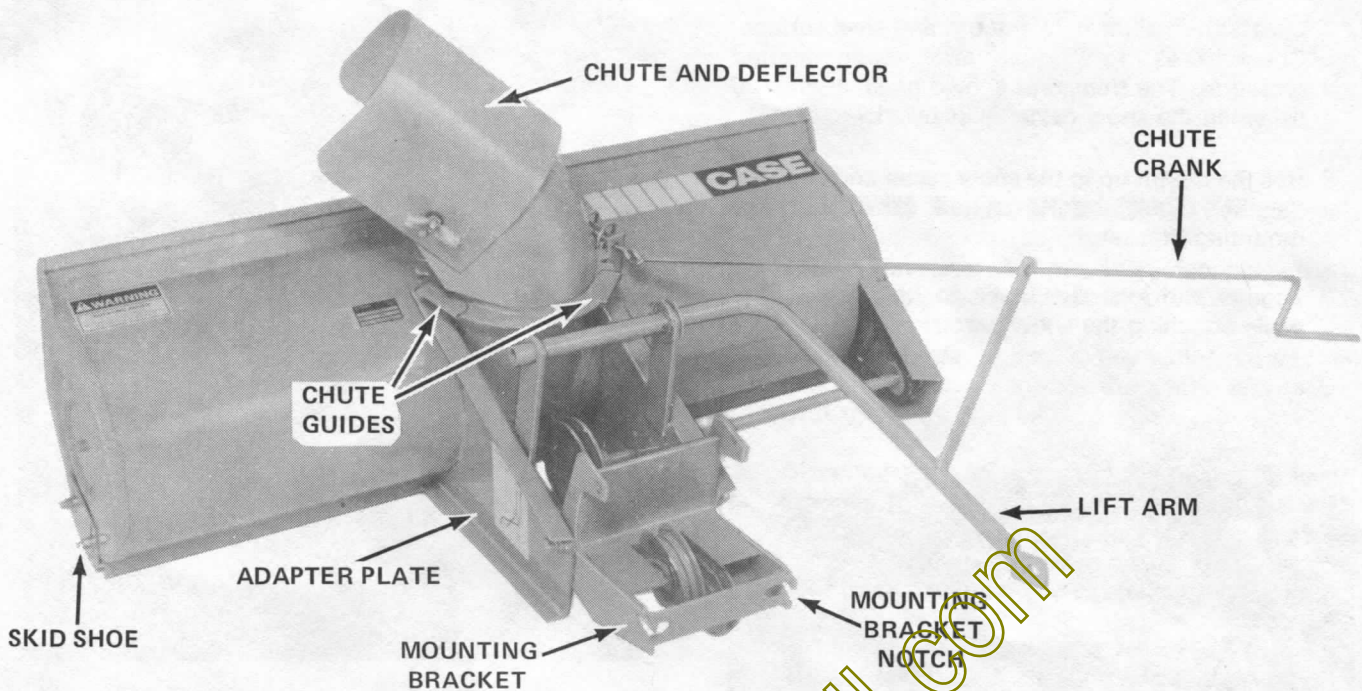

FIGURE 7 Model N84 Snow Caster (Assembled)

1. Remove the components from the box. Check for damage or missing parts.
2. Position the mounting bracket between the auger housing adapter plates as shown in Figure 7.
3. Insert the special shoulder bushing from the outside through the holes in the adapter plates and the upper mounting holes in the mounting bracket.
4. Fasten the mounting bracket to the adapter plates with the one flat washer on the outside and one flat washer and locknut on the inside.
5. Install the skid shoes with the round head bolts. Insert the bolts from the inside with the flat washer, lockwasher and nut on the outside.

Install the skid shoes in their "down" position if the snow caster will be used on a gravel area.

Install the skid shoes in their "up" position if the snow caster will be used on a cement or blacktop area.

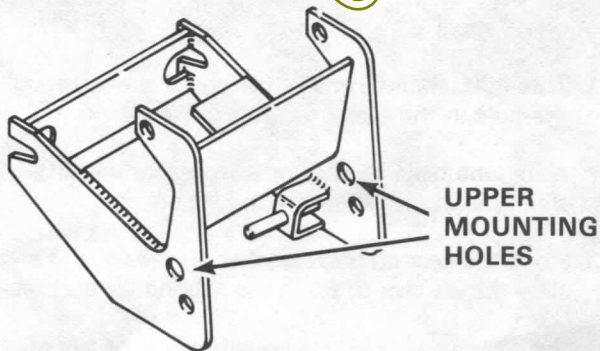

FIGURE 8 Correct Mounting Holes

6. Apply a light coating of grease to the outside of the discharge spout on the auger housing.
7. Place the chute over the discharge spout and engage the base ring notches with the crank spiral.
8. Install two of the chute guides on the sides with the round head of the bolt to the inside. Install the front chute guide with the nut to the inside.

Apply a light coating of grease to both sides of the notched chute base ring.

NOTE: Check to make certain the three guides are square with the chute base ring to prevent the chute from binding when turning the crank.

INSTALLATION

1. Locate the tractor on a smooth and level surface. Check tires for equal and recommended pressures. The front tires should be inflated to 20 psi when the snow caster is installed.
2. Roll the tractor up to the snow caster and align the "anchor pins" and "snap fast pins" with the mounting bracket.
3. Engage and lock the brake to hold the tractor while attaching the snow caster.

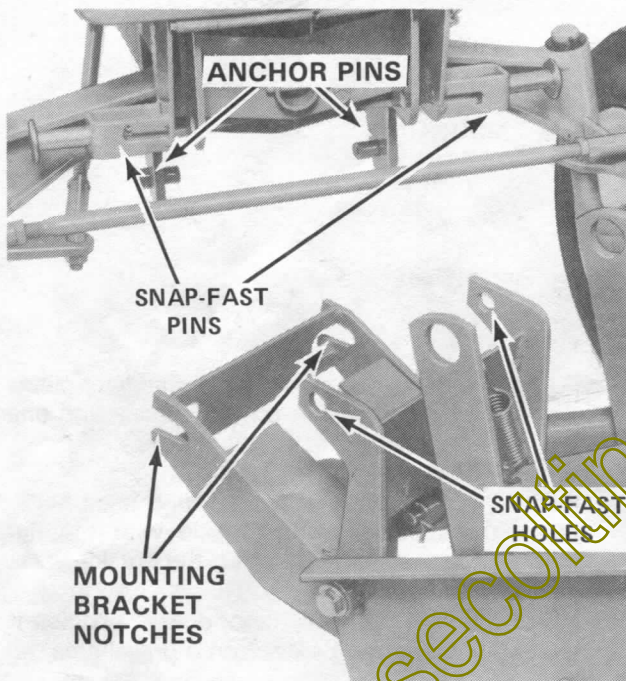

FIGURE 8

4. Lock the tractor "snap fast pins" in the "open" position.
5. Slide the snow caster to engage the mounting bracket notches with the anchor pins on the tractor.
6. Pivot the mounting bracket upward and into the tractor "snap fast pin" receptacles. Release the "snap fast pins" to lock the mounting bracket into position.
7. Two belts are included with the Model N-84 Snow Caster. Use the longer belt when installing the snow caster on a Model 444, 446 or 448 tractor.

Use the shorter belt when installing the snow caster on a Model 222 or 224 tractor.

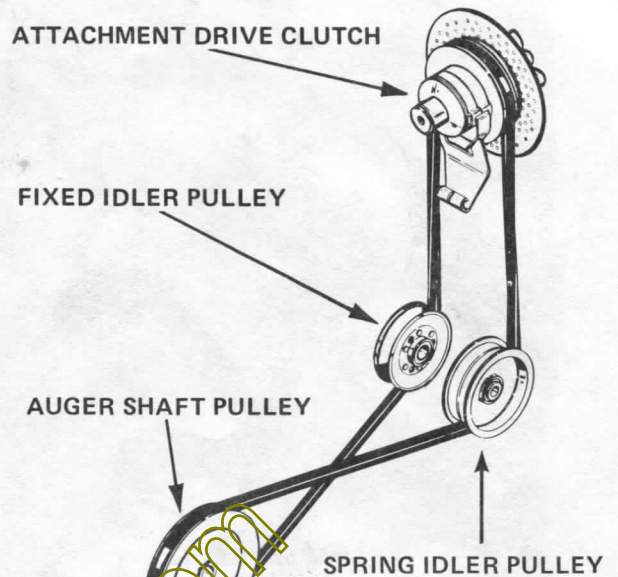

FIGURE 10

8. Engage the attachment drive clutch. Insert the drive belt between the fan and oil cooler and onto the attachment drive clutch pulley. Disengage the attachment drive clutch.
9. Place the belt under the "fixed" idler pulley and around the "auger shaft" pulley. Push down on the "spring idler" pulley lever and locate the belt on the underside. Check the belt to make certain it is correctly installed with the "vee" side in the vee groove pulleys and the "flat" side in the flat groove idler pulley. Manually turn the auger to check for proper belt rotation.
10. Connect the chute crank to the crank spiral by aligning the open ends of each loop and rotating the loop of the chute crank onto the loop of the crank spiral.
11. Thread the handle end of the chute crank through the hole in the crank support on the lift arm.
12. Place one plain washer next to the cotter pin and slide the lift arm through one lift bracket.
13. Place the second plain washer on the lift arm and slide the lift arm through the second lift bracket.
14. Push the washers tight on either side of the right lift bracket and secure with the safety pin.
15. Raise or lower the tractor lift lever to align the hole in the lift arm with the lug on the lift lever. Secure with a plain washer and safety pin.
16. Inflate the front tractor tires to 20 psi (140 kPa).

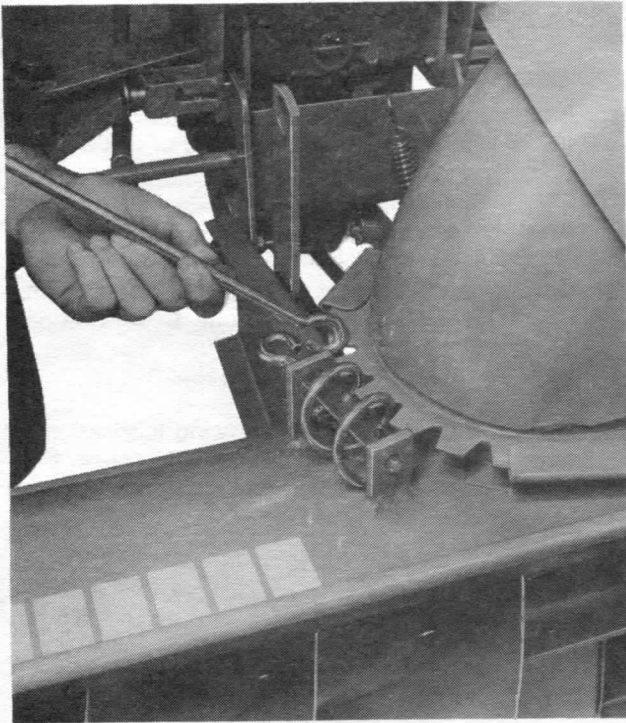

FIGURE 11 Installing Chute Crank

IMPORTANT: Before operating the snow caster, review and follow the recommendations outlined in the Adjustments and Maintenance sections of this manual.

REMOVING THE SNOW CASTER

1. Disconnect spark plug wire as a safety precaution, engage the attachment drive clutch.
2. Push the "spring idler" pulley to loosen and remove the belt. Disengage the clutch and reconnect the spark plug wire.
3. Disconnect the lift arm from the tractor lift lever. Remove the safety pin from the front of the lift arm. Slide the lift arm part way out of the auger lift brackets to clear the tractor. Swing the lift arm with crank attached over the auger assembly.
4. Pull the snap fast pins out to release the mounting bracket and back the tractor away.

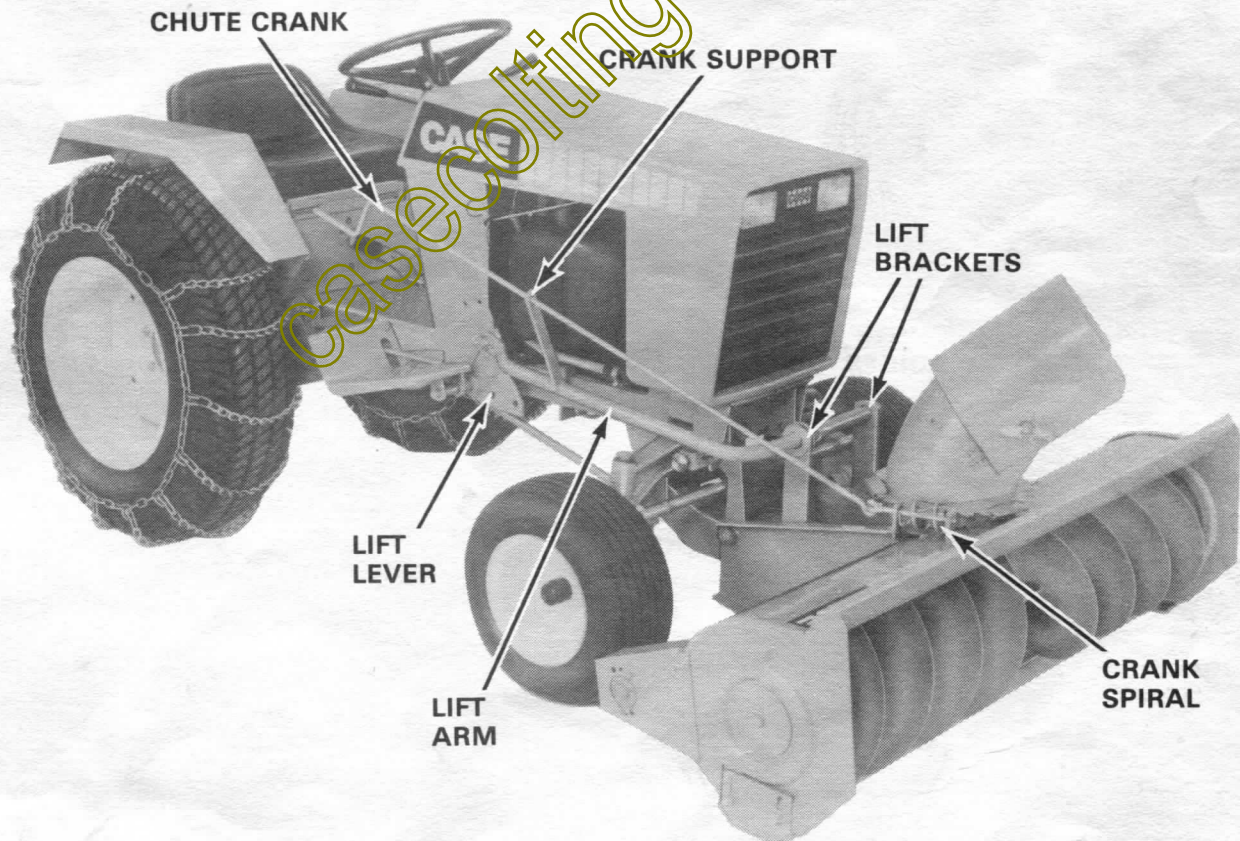

FIGURE 12

MAINTENANCE



CAUTION: Never attempt to service or make adjustments while the snow caster or tractor is running.

Grease the discharge chute crank, chute guides and the chute base ring daily to keep the crank turning freely.

Once a month during season or every 25 operating hours, lubricate the auger drive chain with Case Heavy Duty Chain and Cable Lubricant, or equivalent, available through your Case Compact Tractor Dealer.

At the end of the snow season, the following steps are recommended:

1. Remove the snow caster from tractor following the procedure outlined at the end of this manual.
2. Wash off any salt deposit which may have dried on the auger and chute. Paint or cover exposed metal with a light coat of oil. Case Touch-up Enamel is available through your Case Compact Tractor Dealer.
3. Service the snow caster following lubrication instructions above. Oil the auger drive chain thoroughly using Case Chain and Cable Lubricant to prevent rust from forming.
4. Store snow caster in a dry place.

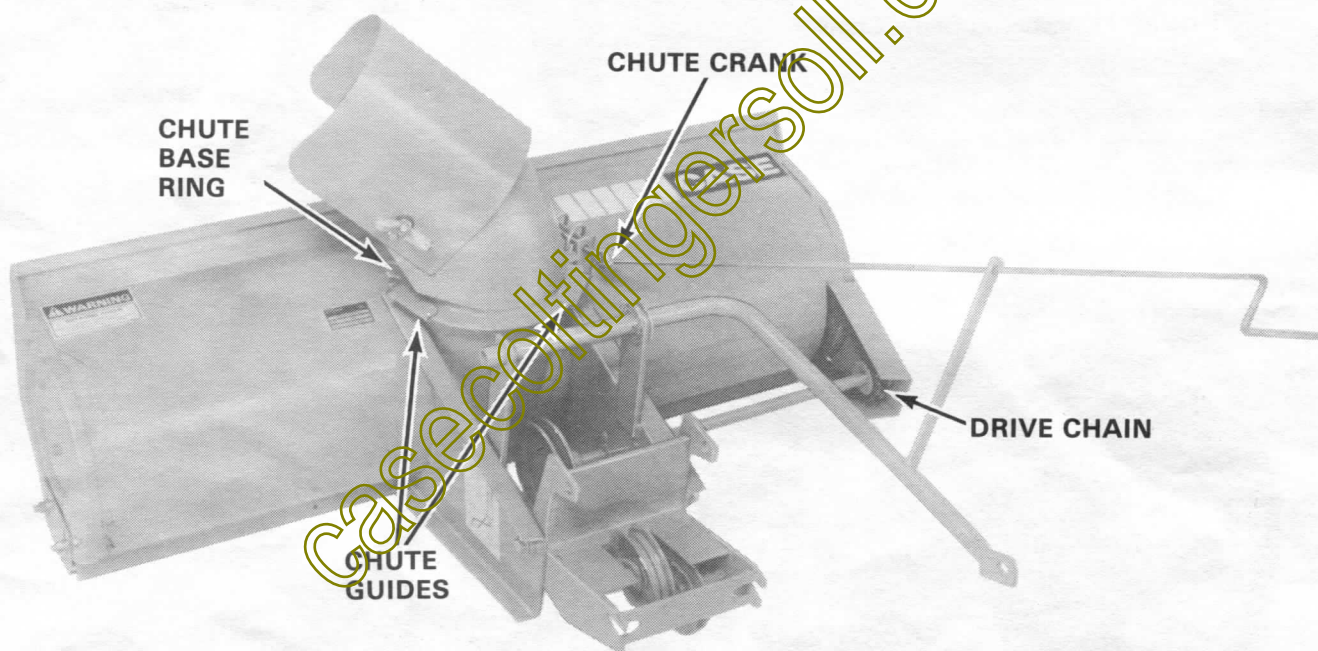

FIGURE 13

casecoltingersoll.com