



ROTARY TILLER

K74, J74

Operator's Manual 9-51672

[casecoltingersoll.com](http://casecoltingersoll.com)

**JI Case**  
A Tenneco Company





**This Safety Alert Symbol Indicates Important Safety Messages In This Manual. When You See This Symbol Carefully Read The Message That Follows and Be Alert To The Possibility Of Personal Injury Or Death**

**IF THIS MACHINE IS USED BY AN EMPLOYEE OR IS LOANED OR RENTED, MAKE ABSOLUTELY CERTAIN THAT THE OPERATOR(S), PRIOR TO OPERATING:**

- 1. IS INSTRUCTED IN SAFE AND PROPER USE.**
- 2. REVIEWS AND UNDERSTANDS THE MANUAL(S) PERTAINING TO THE MACHINE.**

751253



**WARNING**

**BEFORE STARTING ENGINE**

**STUDY OPERATOR'S MANUAL SAFETY MESSAGES  
READ ALL SAFETY SIGNS ON MACHINE  
CLEAR THE AREA OF OTHER PERSONS**

**LEARN & PRACTICE SAFE USE OF  
CONTROLS BEFORE OPERATING**

**IT IS YOUR RESPONSIBILITY TO UNDERSTAND AND FOLLOW MANUFACTURER'S INSTRUCTIONS ON MACHINE OPERATION, SERVICE, AND TO OBSERVE PERTINENT LAWS AND REGULATIONS. OPERATOR AND SERVICE MANUALS MAY BE OBTAINED FROM YOUR EQUIPMENT DEALER.**

# TABLE OF CONTENTS

Safety Rules .....	4 - 5
Introduction .....	6
Tiller Application Chart .....	7
Optional Equipment .....	7
Operating Controls .....	8
Operation .....	9 - 10
Adjustments .....	11 - 12
Maintenance .....	13
Installation .....	14
Removal .....	15

[casecoltingersoll.com](http://casecoltingersoll.com)

## SAFETY RULES



The Safety Rules contained in this manual are to be used together with the safety rules appearing in the tractor operator's manual. Be sure to review both manuals carefully before operating the tractor-tiller combination.



**DANGER:** Spinning Blade - Keep clear of the tiller tines when either the tiller or engine is running.



**CAUTION:** Keep children and pets away from the area while tilling.



**CAUTION:** Stop and inspect the tiller for damage immediately after striking a foreign object and repair any damage before restarting and operating the tiller.



**CAUTION:** Do not allow anyone other than the operator to ride on the tractor.



**CAUTION:** Remove debris that could be thrown by the tiller tines from the area to be tilled. Thrown objects could cause injury.



**CAUTION:** Put the Hydraulic PTO in neutral, lower tiller to ground, shut off engine, and set the parking brake before leaving the tractor seat.



Remember, a careful operator is always the best insurance against an accident. Always give complete and undivided attention to the job at hand.



**CAUTION:** Place the hydraulic PTO lever in neutral, stop engine and remove key before making repairs or adjustments.



**CAUTION:** Only operate controls while seated in the operator's seat.



**CAUTION:** Use extreme care when negotiating inclines and side slopes. Be sure to equip your tractor with a minimum of 115 pounds (52 kg) of front counterweight and 57-1/2 pounds (26 kg) of weight to each rear wheel for 200 series tractors and 150 pounds (68 kg) of front counterweight and 75 pounds (34 kg) of weight to each rear wheel for 400 series tractors with the tiller attached to obtain required overall stability.



Plan your tilling pattern ahead to leave ample room when leaving the plot. Start tilling operations away from close quarters or natural obstacles.





**CAUTION:** Hydraulic systems are highly pressurized. Escaping hydraulic oil, even an invisible pin-hole leak, can penetrate body tissues causing serious injury. Use a piece of wood or cardboard when looking for leaks - never use the hands or other parts of the body.

Relieve hydraulic pressure before disconnecting circuits. When reassembling, make absolutely certain that all connections are tight.

If injured by hydraulic oil escaping under pressure, see a doctor immediately. Serious complications may arise if medical attention is not given at once.

**IMPORTANT:** Always install new decals whenever the old decals are destroyed, lost, painted over or illegible. When individual parts are replaced that have decals attached, be sure to install a new decal with the new part.



**WARNING:** Be sure the Hydraulic PTO lever is in the neutral position before starting the tractor. This control is not equipped with a neutral start switch and accidental rotation of the tiller tines could cause injury.

**NOTE:** If your tractor is equipped with the optional flow control valve:



**CAUTION:** The optional flow control valve is NOT a hydraulic brake. For effective RETARD, the optional flow control valve lever should be placed in the full speed position and the tractor travel lever placed in the RETARD detent. Consult your tractor operator's manual.

casecoltingersoil.com

## INTRODUCTION

This operator's manual is for the Model K74 and J74 rotary tiller. This operator's manual includes:

- a. Safety Rules
- b. Installation Procedure
- c. Operating Procedure
- d. Adjustments
- e. Maintenance

Read this manual before operating your rotary tiller

See your J I Case dealer for parts or repairs.

The J I Case Company reserves the right to make improvements in design or changes in specifications at any time, without incurring any obligation relating to such changes.

The words "Right, Left, Front and Rear" as used in this manual indicate directions when you are in the operator's seat in the normal operating position.

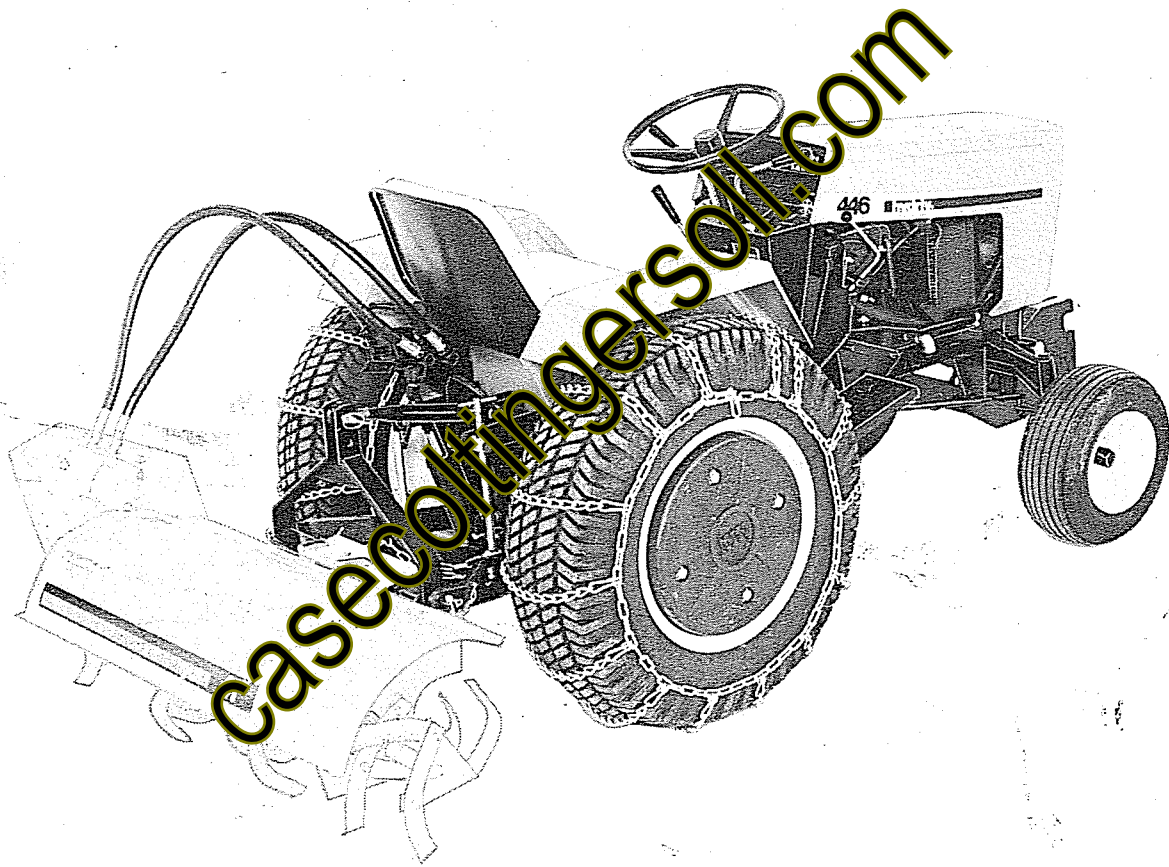

FIGURE 1 Rotary Tiller Shown with Model 446 Tractor, Hydraulic PTO, Front Weight Kit, Rear Wheel Weights, Tire Chains, 3-Point Hitch and Flow Control Valve

## TILLER APPLICATION CHART

TRACTOR MODEL	HITCH	HYD. PTO	OPTIONAL FLOW CONTROL	HOLDING VALVE	WHEEL WEIGHTS	HYD. LIFT	FRONT WEIGHTS	CHAINS
* 220, 222, 224, 226	*** H-22, J-22 or K-22 Sleeve	J-17	*** † L-19 or M-19	L-7	K-8	Required	L-11 or H-18 & K-8 or H-13 Box with 150# Ballast	D-12
444, 446, 448	*** H-24, J-24 or K-24 Sleeve or H-26 or J-26 3-Pt. + F-27 Sleeve Adapter	*** J-17 or L-17	*** † L-19 or M-19	*** L-9 or M-9	K-10	Required	L-11 or H-18 & K-10 or H-13 Box with 150# Ballast	E-16
644	LT-26 3-Pt. Hitch + F-27 Sleeve Adapter	LK-17	Not Available	LL-9	D-10	Required	** Not Available	LT-15
646, 648	LT-26 3-Pt. Hitch + F-27 Sleeve Adapter	LT-16	Not Available	LL-9	D-10	Required	** Not Available	LT-15

\* You must order SS74 Stub Shaft Kit to reduce the tiller size to 32" (812 mm) for use on Model 220 and 222 tractors.

\*\* Apply 150# ballast to front bucket.

\*\*\* See your dealer for correct attachment model number.

† Tractors with mufflers under the hood only. For mounting to prior model tractors, consult your dealer.

### OPTIONAL EQUIPMENT REQUIRED FOR BEST PERFORMANCE

See the above application chart for available optional equipment.

You must add counterweight to your tractor when you use heavy attachments. This will give you better control and efficiency. Rear wheel weights and tire chains make an improvement in traction and stability. Front end weights will make an improvement in steering control and stability. When the weight box is used on the front of the tractor, add 150 lb. (68 kg) of ballast. See Figure 2 for a tractor using the correct optional equipment.



**CAUTION:** Use extreme care when negotiating inclines and side slopes. Be sure to equip your tractor with a minimum of 115 pounds (52 kg) of front counterweight and 57-1/2 pounds (26 kg) of weight to each rear wheel for 200 series tractors and 150 pounds (68 kg) of front counterweight and 75 pounds (34 kg) of weight to each rear wheel for 400 series tractors with the tiller attached to obtain required overall stability.



## OPERATING CONTROLS

The operating controls of your rotary tiller are identified in Figure 2 with the same nomenclature used throughout this manual.

### HYDRAULIC PTO LEVER

The tiller tines are placed in motion by engaging the Hydraulic PTO lever.

### TRACTOR TRAVEL LEVER

Tractor ground speed is controlled by the tractor travel lever or by a combination of the tractor travel lever and optional flow control valve if so equipped.

### HIGH-LOW RANGE SHIFT LEVER

The range shift lever must always be in low range when tilling.

### ATTACHMENT LIFT LEVER

The tiller is raised and lowered with the attachment lift lever.

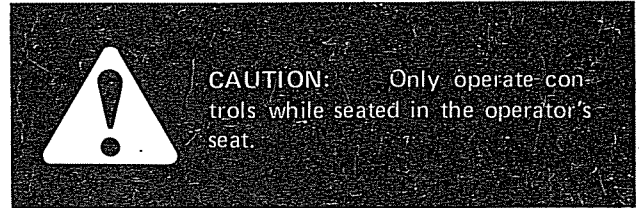

Tilling should always be done with the engine at full throttle to achieve maximum power, maximum tine speed and prevent engine lug down and subsequent overheating.

After hard usage, allow the engine to run at 1/3 throttle for two to five minutes to allow engine parts to cool evenly before shutting off.

**NOTE:** See your tractor Operator's Manual for a more detailed description of tractor operating controls.

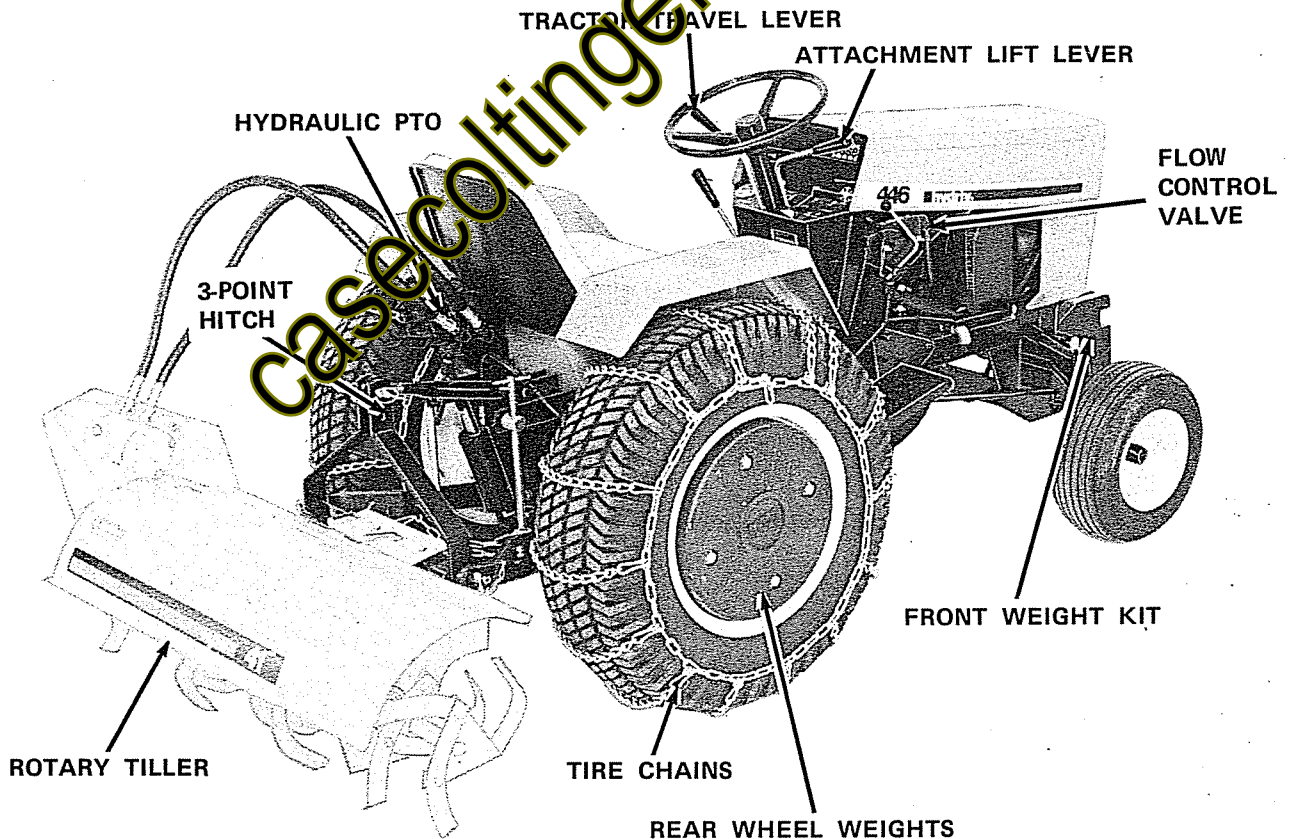

FIGURE 2



## OPERATION

Check the work area before you put the tiller into operation. Clear the area of large stones and obstructions. They can cause damage to your tiller.

### LIFT LEVER OPERATION AND DEPTH ADJUSTMENT

The attachment lift lever has four positions:

1. "Neutral" - Center position. The lever will return to neutral automatically when released except from the "float" position.
2. "Raise" - Pull lever rearward. Release lever.
3. "Lower" - Push lever partway forward. Release lever.
4. "Float" - Push lever fully forward. The lever must be manually removed from the "float" position.

The tiller should always be allowed to float with the contour of the ground. Do not use "Down Pressure" on the tiller as this can lift the rear tractor wheels off the ground and cause loss of traction or damage the tiller.

### SLEEVE HITCH

The sleeve hitch allows the tiller to float. Therefore, the "float" position of the attachment lift lever does not have to be used.

### THREE-POINT HITCH

The attachment lift lever must be in the "float" position when using the tiller with the three-point hitch.

### TRACTOR TRAVEL SPEED

Keep the tractor travel speed slow to permit the most efficient operation. Always use the low range of the two speed transaxle.

The tractor travel speed will change in relation to the soil conditions. Adjust the travel control lever to keep the speed constant. If the tiller is pushing the tractor, put the travel lever a small amount into the "reverse" position. This will decrease the travel speed without damaging the tractor.

**IMPORTANT:** Do not travel in reverse while the tiller is lowered. Damage to the tiller can occur.

### HYDRAULIC PTO

The tiller tines are actuated with the hydraulic PTO. See Figure 3.

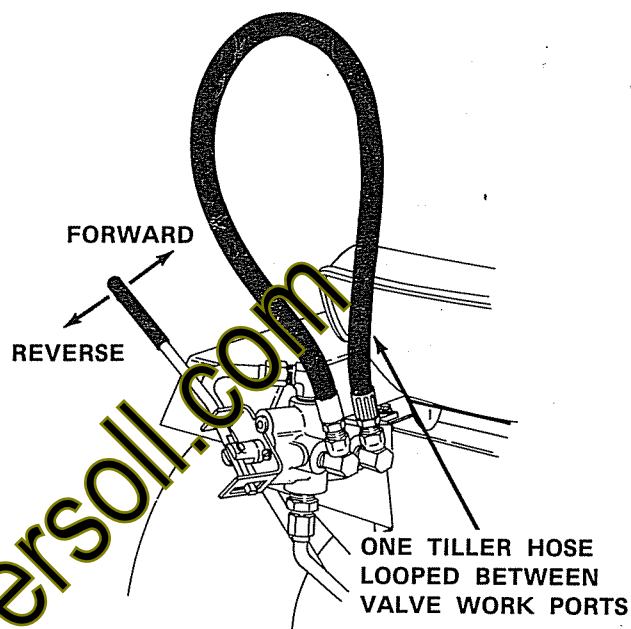

FIGURE 3 Hydraulic PTO

#### CLOCKWISE TINE ROTATION (FORWARD)

Pull the PTO lever completely forward.

#### COUNTERCLOCKWISE TINE ROTATION (REVERSE)

Push the PTO lever completely rearward.

If the tiller tines do not rotate correctly, check the hydraulic hoses for correct installation. See the Mounting Section of this manual.

Always move the PTO handle full travel when you engage the tiller. This will give you maximum speed and power.

The Hydraulic PTO may be left on the tractor when the tiller is removed.

The Hydraulic PTO may be used to drive other hydraulically driven devices. Consult your dealer for further information.

**VERY IMPORTANT** Only operate the tractor with tiller hoses connected or one hose looped between the valve work ports. (Fig. 3) Failure to observe this procedure will result in oil loss (ports left open) or pump damage (ports plugged) if the valve is actuated.

### TILLER TINE SPEED

Engage the tiller tines into "forward" rotation while the tiller is in the "transport" position. Use the "reverse" rotation only to free the tines from rocks, roots, or other obstructions.

Always operate the tiller with the tractor engine at full throttle (3600 rpm). This will give maximum tine speed for:

1. most efficient tilling
2. full horsepower
3. correct engine cooling

Keep the tine rotation at the maximum rpm while tilling. If the soil conditions decrease the tine speed, decrease the tractor travel speed. Permit the tine speed to return to full rpm.

To keep the tine speed at full RPM during severe conditions lift the tiller a small amount.

For increased tine speed, optional drive sprockets are available from your normal parts source. See Adjustments section of this manual for more information.

### OPTIONAL FLOW CONTROL VALVE

The flow control valve permits a more accurate control of the tractor travel speed. This is especially important for severe soil conditions and large jobs.

For the correct use of the flow control valve, follow this procedure:

1. Put the lever of the flow control valve in the "off" position (completely rearward).
2. Put the tractor travel lever fully into the "forward" position.

3. Move the lever of the flow control valve forward until the needed speed is reached.
4. You can move the tractor travel lever while the flow control valve is in any position. No tractor damage will occur.
5. The flow control valve does not prevent the use of the tractor travel control:
  - a. Put the flow control lever fully forward.
  - b. move the tractor travel lever for complete control of travel.
6. The hydraulic lift will not operate while the flow control valve is in the "off" position. The speed of the hydraulic lift is in direct relation to the setting of the flow control valve!
7. Maximum travel speed can be slower on a tractor if equipped with the flow control valve.

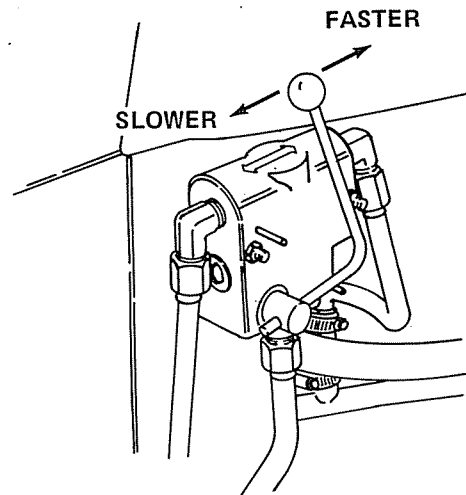
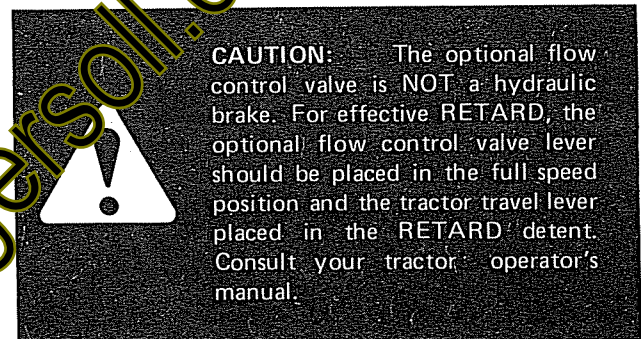

FIGURE 4 Flow Control Valve

## ADJUSTMENTS



**CAUTION:** Place the hydraulic PTO lever in neutral, stop engine and remove key before making repairs or adjustments.

### OFFSET MOUNTING

There are alternate hole locations in the hitch. They permit the tiller to be set at an offset of 3" (75 mm) to the right. This permits a better control of the tiller while operating near obstructions.

### TILLER TINE CUTTING EDGE

Check the cutting edge of the tiller tines periodically. Keep them sharp for best results. If the tines are beyond repair, new tines are available from your J I Case dealer.

### TILLER TINE ARRANGEMENT

The position of each tiller tine is important. Do not operate the tiller with a tine removed.

The tines on the right hand end of the tiller have the offset toward the center of the tiller. This provides a smooth cut, limits side thrust of the soil, and permits operation nearer to obstruction.

In special conditions it can be desirable to operate the tiller tine rotating in the reverse direction. To till effectively in this manner, the tines should be removed and turned so the sharpened edge leads when the tiller shaft is rotating in the reverse direction. Arrange the tines on the right hand end so the offset is toward the center of the tiller. Two tines from one hub and one tine from a second hub will be required to do this.

### REMOVABLE 9" SECTION

Some soils are very hard, or dense with root structures resulting in extremely difficult tilling conditions. The right hand shaft and shield assemblies can be removed to reduce the tiller width to 32 inches (812 mm) for such difficult tilling conditions. At this reduced width the tiller will penetrate faster and will use tractor horsepower more efficiently.

The extension can be replaced after initial surface tilling has been completed. Do not replace the extension on Models 220 and 222.

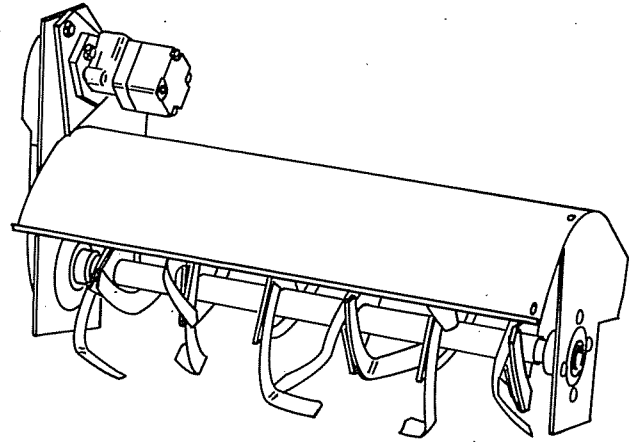

FIGURE 5 Tiller with 9" Section Removed

### SS74 STUB SHAFT KIT REMOVAL AND INSTALLATION

**NOTE:** AN OPTIONAL STUB SHAFT KIT MODEL SS74 MUST BE OBTAINED FROM YOUR DEALER IN ORDER TO USE THE TILLER WITH THE 9" EXTENSION REMOVED.

1. Remove the bolts which secure the shield extension to the main shield. Remove the shield extension.
2. Remove the cotter pin and clevis pin which secure the extension shaft to the tiller main tine shaft.
3. Loosen the set screw on the locking collar for the bearing. Insert a punch into the hole in the collar next to the set screw and tap in the direction **OPPOSITE** the direction of rotation. This will loosen the locking collar.
4. Pull the extension shaft out of the tiller main tine shaft.
5. Loosen the four bearing flangette mounting bolts.
6. Apply anti-seize compound to the stub shaft and insert into the tiller main tine shaft.
7. Align the holes and insert the clevis pin and cotter pin to secure the stub shaft to the tiller main tine shaft.
8. Tighten the four bearing flangette mounting bolts.
9. Tap the locking collar in the direction the **SAME AS** the direction of rotation. Tighten the set screw.

10. To remove the stub shaft:
  - a. Remove the threaded plastic plug.
  - b. Thread a bolt into the hole.  
(A steel plate approximately 2" x 4" by 1/4" thick with a 1/2 inch diameter hole can be installed with the bolt. This will provide a "handle" if the stub shaft sticks.)
  - c. Remove the cotter pin and clevis pin.
  - d. Loosen the set screw on the locking collar for the bearing. Insert a punch into the hole in the collar next to the set screw and tap in the direction OPPOSITE the direction of rotation. This will loosen the locking collar.
  - e. Pull the stub shaft from the tiller tine shaft.

**NOTE:** Apply anti-seize compound to the stub shaft or 9" extension when reinstalling it to the tiller main tine shaft. The use of anti-seize compound will permit easier removal at a later time.

#### OPTIONAL DRIVE SPROCKETS

Optional drive sprockets are available from your dealer. You can use these sprockets to compensate for certain soil conditions.

##### 13 TOOTH SPROCKET:

- (a) Standard on J74 tillers
- (b) For hard to average soil conditions
- (c) For lower horsepower tractors (10 or 12 hp)
- (d) No load maximum speed is approximately 150 RPM

##### 15 TOOTH SPROCKET:

- (a) Standard on K74 tillers
- (b) For average soil conditions
- (c) For 14 hp and larger tractor
- (d) No load maximum speed is approximately 170 RPM

##### 17 TOOTH SPROCKET:

- (a) Optional
- (b) For average to light soil conditions
- (c) For 16 hp and larger tractors
- (d) No load maximum speed is approximately 190 RPM

#### DRIVE SPROCKET CHANGE PROCEDURE

1. Remove the upper cover from the chain case.
2. Remove the bolt that holds the sprocket on the drive motor shaft.
3. Remove the forward bolt from the motor mounting plate.
4. Loosen the rear bolt on the motor mounting plate.
5. Lower the motor mounting plate until it makes contact with the tiller housing.

6. Hold the chain up and remove the sprocket from the motor shaft.
7. Install the new sprocket into the chain and on the motor shaft. The sprocket hub is to the outside.
8. Rotate the motor plate up to tighten the chain. Install the forward bolt into the motor plate and into the correct hole on the tiller housing. See the illustration.
9. Tighten the bolts in the motor mounting plate.
10. Install the sprocket mounting hardware. Use Locktite #21 on the bolt.

**IMPORTANT:** Do not use a large amount of Locktite or the sprocket will be difficult to remove.

11. Install the upper cover on the chain housing.

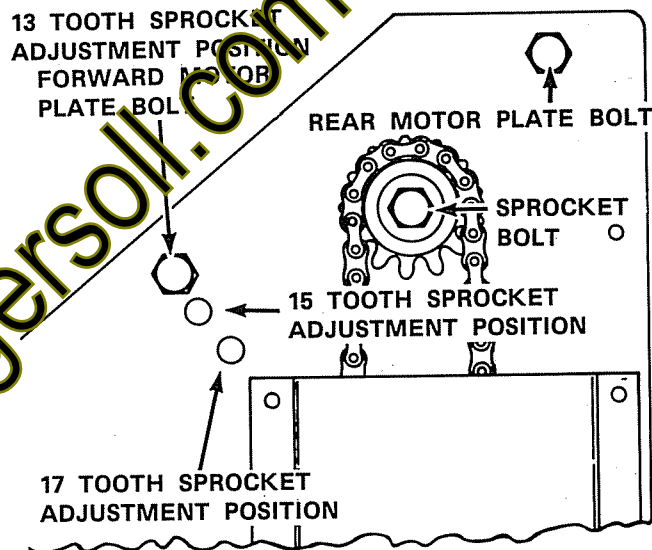

FIGURE 6 Drive Sprocket

#### TIRE PRESSURE

Maintain tractor tires to the air pressure specified below.

Tire Size	Type	PSI	k Pa	
6:50 x 8	Front (High flotation)	14	96	With front end weight applied
8:50 x 12	Rear (High flotation)	10	68	With rear wheel weights and tiller mounted
8:00 x 16	Rear (High flotation)	14	96	With rear wheel weights and tiller mounted
18x8:50-8	Front (High flotation)	22	150	
8:50 x 15	Rear - Traction	14	96	With rear wheel weights and tiller mounted



## MAINTENANCE

### DAILY CHECKS

1. Check all fasteners and hydraulic connections. Tighten as required.
2. Check for damaged tines or shields. Repair as required.
3. Check the tractor air cleaner element. See your tractor operator's manual for correct air cleaner maintenance procedures.
4. Check the air intake screen of the engine. Remove all the dirt and debris. If the operating conditions are severe, check several times a day.
5. Check the hydraulic heat exchanger. Remove all the dirt and debris from the cooling fins. If the operating conditions are severe, check several times a day.
6. Check the oil level of the engine. Keep the oil level according to your tractor operators manual.

**IMPORTANT:** See your tractor manual for more complete information on tractor maintenance.

### TILLER CHAIN HOUSING

Check the chain housing once each year. Check more often if you see leakage. Use multipurpose gun grease as required.

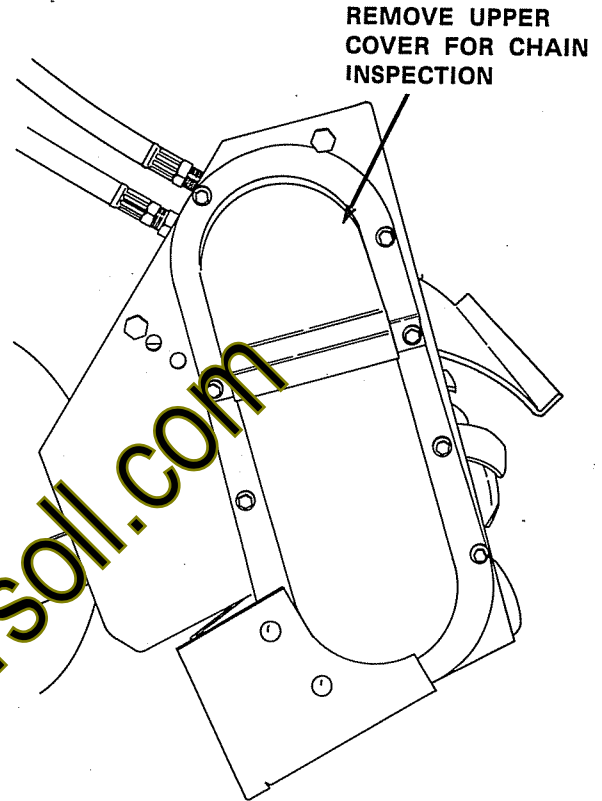

FIGURE 7 Chain Housing

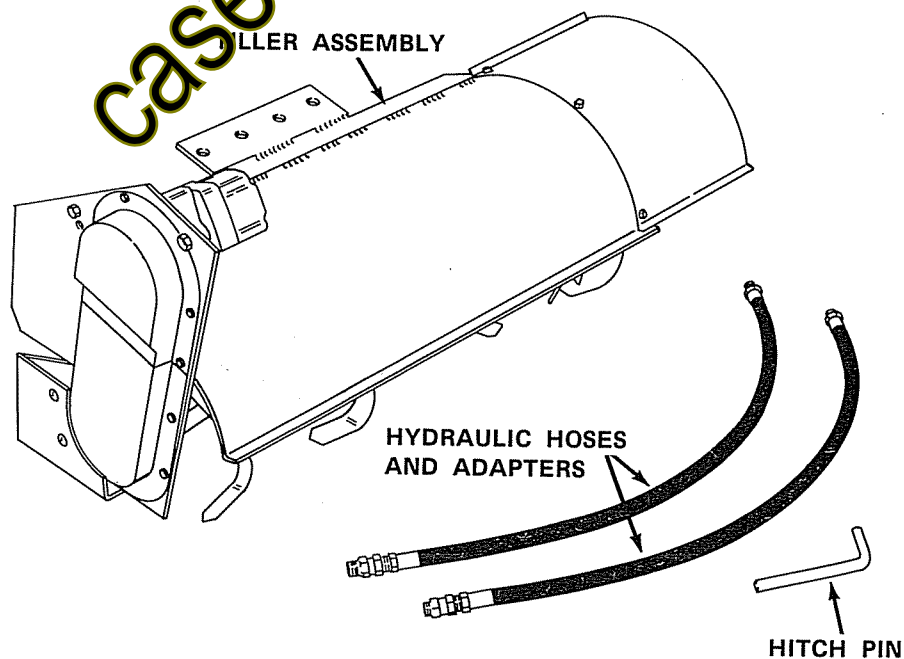

FIGURE 8 Tiller Disassembled

## INSTALLATION

See the Tiller Application Chart on page 7. Make sure the tractor has the correct hitch, weights and hydraulic lift.

1. Put the tiller on the hitch and install the two hitch pins. See the Offset Mounting section for additional information.
2. Install the adapter fittings into the ports of the hydraulic motor on the tiller.

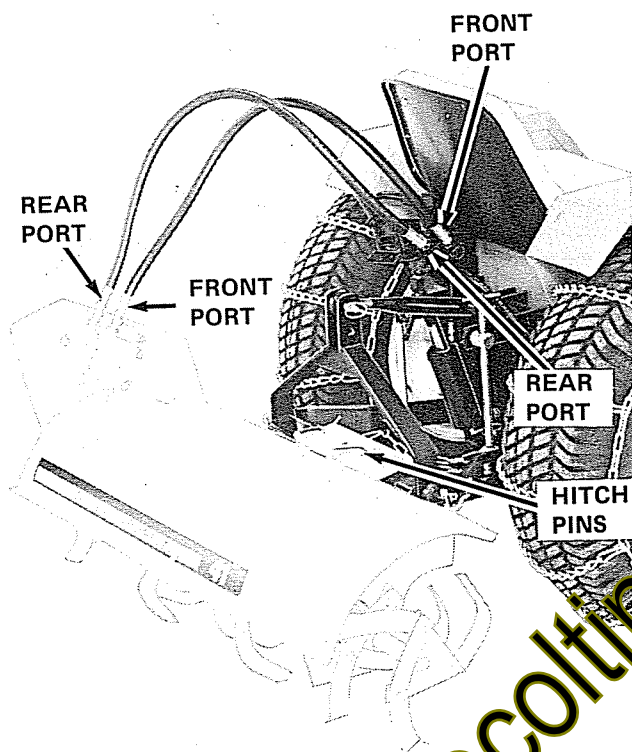

FIGURE 9 Hose Connections

3. See Figure 9. Install the hoses from:
  - a. The front port of the PTO valve to the front port of the tiller motor.
  - b. The rear port of the PTO valve to the rear port of the tiller motor.
4. Tighten the two stabilizer bolts located on the hitch, against mounting bracket of the tiller.
5. Start the tractor. Raise the tiller into the transport position. Check for correct tine rotation. The tines will rotate clockwise when the PTO lever is pulled forward. If the rotation is opposite, reverse the hose connections at the PTO valve.



**CAUTION:** Only operate controls while seated in the operator's seat.



**CAUTION:** Hydraulic systems are highly pressurized. Escaping hydraulic oil, even an invisible pin-hole leak, can penetrate body tissues causing serious injury. Use a piece of wood or cardboard when looking for leaks - never use the hand or other parts of the body.

Relieve hydraulic pressure before disconnecting circuits. When reassembling, make absolutely certain that all connections are tight.

If injured by hydraulic oil escaping under pressure, see a doctor immediately. Serious complications may arise if medical attention is not given at once.

6. Check all hydraulic connections for leaks.
7. Check and tighten all bolts as required.
8. Check the oil level in the hydraulic reservoir of the tractor. Add oil as required. See the tractor manual for the correct oil level and oil specifications.



**CAUTION:** Put the Hydraulic PTO in neutral, lower tiller to ground, shut off engine, and set the parking brake before leaving the tractor seat.

## REMOVAL

1. Lower the tiller to the ground. Stop the engine.
2. Loosen the two stabilizer bolts located on the hitch.
3. Disconnect one hose from the PTO valve. Keep it in a raised position to minimize the loss of oil.
4. Disconnect the other hose from the tiller motor. Keep it in a raised position to minimize the loss of oil.
5. Connect the free end of the PTO hose to the open fitting on the PTO valve. See Figure 10.
6. Connect the other hose between the two ports of the tiller motor.

**VERY IMPORTANT:** While the tiller is removed, install a hose between the open ports on the PTO valve. Failure to follow this procedure will cause:

1. loss of oil while the ports are open.
2. pump damage if the PTO is actuated while the ports have a plug.

7. Remove the 2 hitch pins.

8. The PTO valve and flow control valve can stay installed while not in use. They will cause no interference for most other attachments.

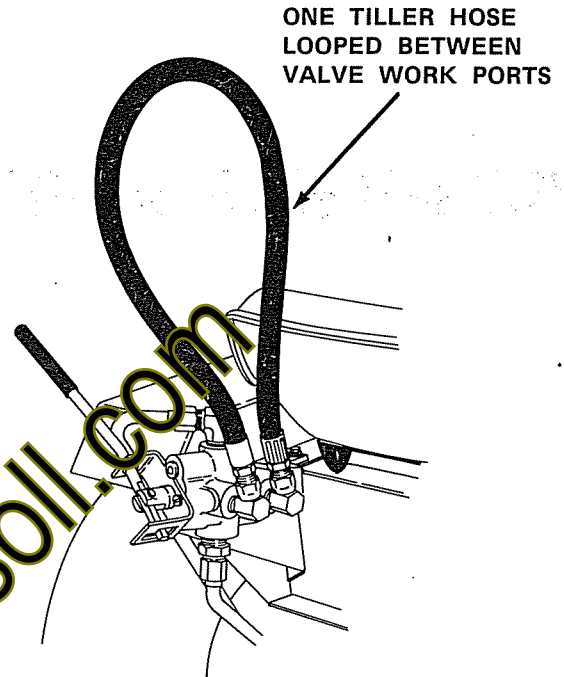

FIGURE 10 Hydraulic PTO

[casecoltingersoll.com](http://casecoltingersoll.com)