



Rotary Mower

J40, J44 and J46

Operator's Manual No. 9-50551

JI Case
A Tenneco Company



INTRODUCTION

The model J-40 Rotary Mower is designed to mount on models 210, 220, 222 and 224 compact tractors above serial number 9646800. Model J-44 Rotary Mowers mount on models 210, 220, 222, 224, 442, 444 and 446 tractors above serial number 9646800 and models 644 and 646 loader tractors. The model J-46 Mower will mount on the same tractors as the J-44, however, it is not recommended for the model 210 or 220. These mowers can be mounted on Model 220 and 222 tractors prior to serial number 9646800 by using the Model H38 Adapter Kit. The Model H39 Adapter Kit is required to mount these mowers on Model 442 and 444 compact tractors prior to serial number 9646800. The Adapter Kits are available as optional equipment.

NOTE

- A. When mounting J series mowers on tractors without rubber engine mounts use belt part number C17050 for 200 series tractors and C17052 for 400 series tractors.

- B. When mounting J-44 or J-46 mowers on the 646 loader use belt part number C13184 which is supplied with the tractor.

- C. When mounting the J-44 or J-46 mowers on the 446 tractor one offset lift link, part number C19652 is required. This link is supplied with the tractor.

NOTE

This manual covers recommended operating procedures, safety suggestions, adjustments, maintenance information, and installation instructions. Read this manual carefully before operating your rotary mower. Your J I Case Compact Tractor Dealer is well qualified to answer any further questions you might have concerning your rotary mower. Also, if the need should arise, his Service Department with factory trained technicians, genuine Case replacement parts and the required facilities is in a position to provide proper repairs in the shortest time possible.

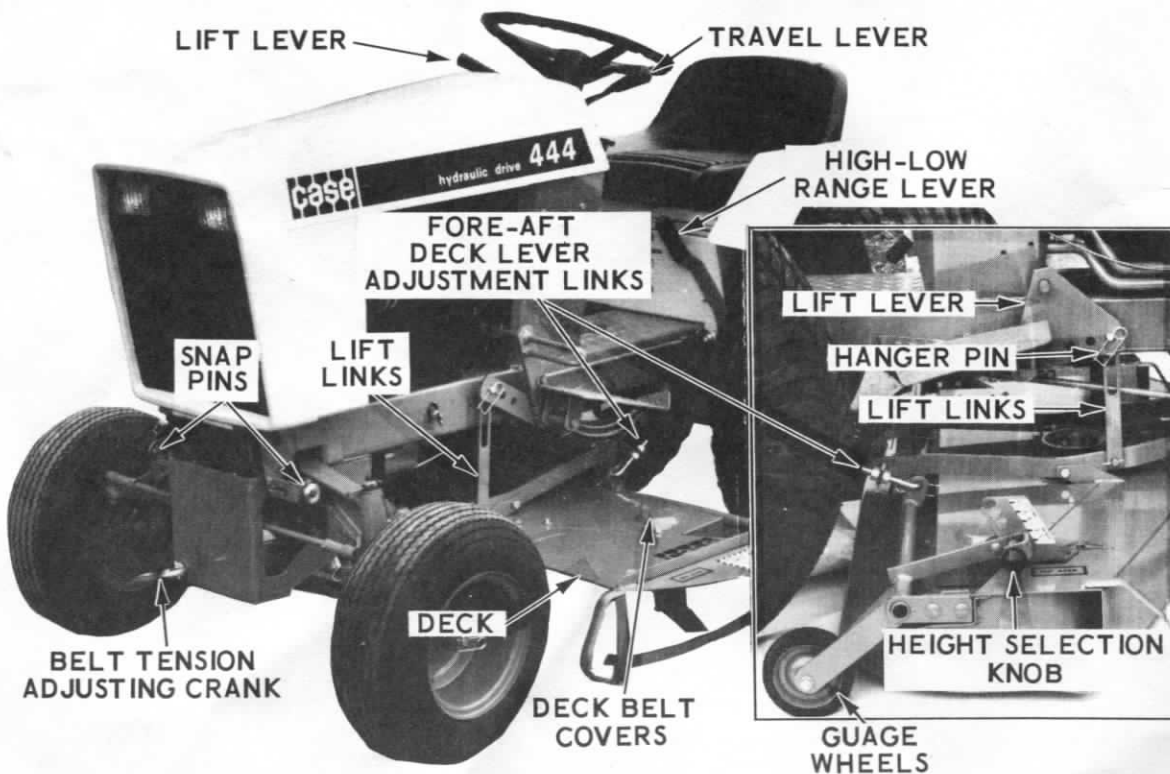

Figure 1.

The definitions "Right, Left, Front and Rear" as used throughout this manual relate to the tractor and rotary mower as the operator is seated facing forward in the normal operating position on the tractor.

Always make certain the tractor attachment drive clutch is disengaged before starting the engine and when transporting the rotary mower.

OPERATING CONTROLS

The principle components and controls of your rotary mower are identified in Figure 1 with the same description used throughout this manual.

All controls are conveniently located near the operator's position on the tractor. The mower blades are placed in motion by engaging the tractor attachment drive clutch lever. The desired mowing height can be quickly adjusted with the height selection

knob. See inset photo, Figure 1. Generally best performance is obtained with the transmission in "Low" range and the engine running approximately 3/4 throttle. The throttle should be set as low as practical to obtain maximum fuel economy but high enough to prevent engine lug-down or labor which could cause overheating and poor mowing. Adjust the tractor ground speed with the Travel lever according to your mowing conditions.

OPERATING SAFETY SUGGESTIONS



LOOK FOR THIS SYMBOL
TO POINT OUT IMPORTANT
SAFETY PRECAUTIONS

1. Regard your rotary mower as a piece of power equipment and be sure this manual is read and understood by all who operate it.
2. Clear the lawn or area to be mowed of sticks, stones or any hard objects which could come in contact with the blades and be hurled out the discharge opening.
3. Do not permit children or pets in the area while mowing.
4. KEEP FEET AND HANDS AWAY FROM DISCHARGE OPENING AND MAKE NO REPAIRS UNLESS BOTH THE TRACTOR ENGINE AND PTO ARE SHUT OFF.
5. Fill gas tank out of doors and avoid spilling gasoline. Do not fill tank with gasoline while smoking or while engine is running.
6. Never allow children or young teenagers to operate the tractor and rotary mower.
7. Maintain your tractor and rotary mower in top operating condition.
8. Never get on or off the tractor while mower is running.
9. Operate in "Low" range and use greater caution on steep slopes or inclines.
10. Be sure you know how to stop the tractor and mower at a moments notice.
11. Give complete and undivided attention to the job at hand.
12. Stop the engine and disengage the attachment drive when tractor is unattended.
13. Disengage attachment drive clutch when someone approaches.
14. Do not allow anyone other than the operator to ride on the tractor.
15. Never direct the mower discharge at people, pets, windows, or cars.
16. Disengage the attachment drive clutch whenever mower is in transport or lifted position.
17. STOP AND INSPECT THE MOWER FOR DAMAGE IMMEDIATELY AFTER STRIKING A FOREIGN OBJECT AND REPAIR DAMAGE BEFORE RESTARTING AND OPERATING THE MACHINE.

OPERATING METHODS AND TIPS

1. Keep mower blades sharp and balanced as covered in Adjustments and Maintenance Section.
2. Operate engine at approximately 3/4 throttle and regulate the ground speed Travel Lever according to mowing conditions. As a general rule, set the throttle as low as practical to obtain maximum fuel economy but high enough to avoid engine lug-down or labor which could cause overheating. Unless grass is unusually light, always operate in "Low" speed range.
3. If grass is heavy and higher than normal, results can be improved by mowing twice. Make the first cut with the mower set higher than normal; then repeat with the mower set at desired finished cut height. When mowing heavy grass, always discharge clippings away from the uncut area.
4. Figures 2 and 3 illustrate two systems for mowing. If the grass is high or heavy, always mow to throw the clippings away from the uncut area, Figure 2. If the grass is light and more thorough mulching is desired, discharge the clippings toward the center of the uncut

area, Figure 3. When mowing in this manner, a final strip of mulched clippings about three to four feet wide will remain near the center of the lawn. This can be easily raked up to leave a well groomed appearance.

5. Trimming will be neater and closer by using the right side of the mower since the clippings will be discharged away from the object. Also the safety shield over the discharge opening prevents mowing as close to objects.
6. Do not step on the mower deck when getting on or off the tractor. If mounting the tractor from the right side, place your right foot on the right foot rest, your right hand on steering wheel and left hand on the seat back and step onto the tractor, swinging your left foot through between the steering wheel and seat.

When mounting from the left side, start with your left foot on the left foot rest, your left hand on steering wheel and right hand on seat back and step onto tractor swinging your right foot through between steering wheel and seat.

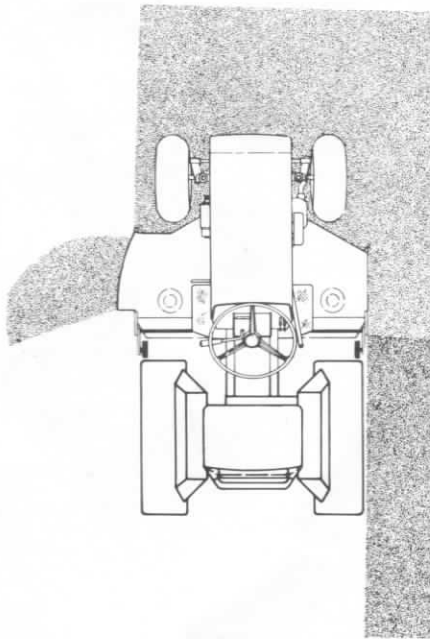

Figure 2.

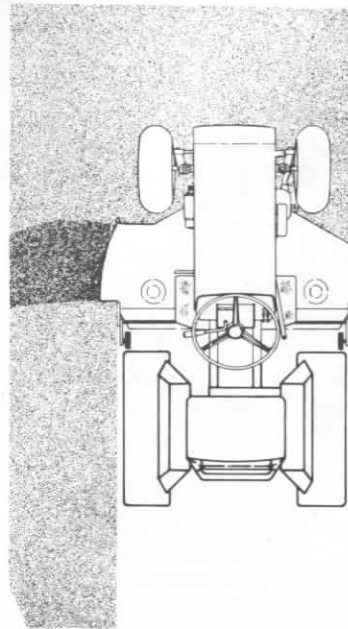

Figure 3.

Dismount the tractor using the reverse of the above procedures.

- The tractor mechanical or hydraulic lift lever is used to raise the mower into transport and to lower it into cutting position. A slight pulling pressure on the mechanical lever will permit the release button to be more easily depressed. The "Height Selection" settings are explained in the ADJUSTMENT AND MAINTENANCE section which follows.

- Engage tractor and mower drive systems smoothly - not quickly or jerky.



- Be certain whoever operates the mower has read and understands the preceding "Operating Safety Suggestions."

ADJUSTMENTS AND MAINTENANCE

- Height Selection Lever: See Figure 4

The mower cutting height is adjustable from 1-1/2" to 3-1/2" with 1/2" settings available in between. To change the cutting height, pull outward on the selection knob, move the lever up or down to desired height setting and push back into matching hole. Relieve the weight on the selection lever by raising mower into transport position before adjusting the cutting height. Always operate the mower with the gauge wheels on the ground and all weight off the mower lift links to obtain a level and uniform cut.

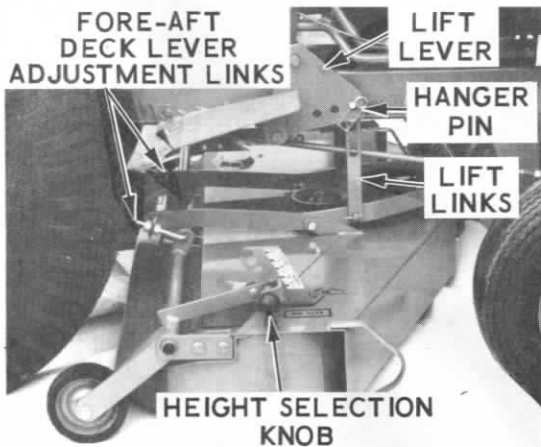

Figure 4.

- Drive Belt Tension: See Figure 5.

The drive belt is properly tensioned when the two front idler pulleys are in line (parallel with each other).

Check and adjust the tension on a new belt after the first 20 minutes and the next hour of mowing since it is normal for a belt to stretch slightly during its initial run-in period. To increase the belt tension, turn the adjusting crank in a counterclockwise direction while facing the front of the tractor. It is also necessary to turn the adjusting crank counterclockwise as far as it will go in order to attach or remove the mounting bracket from model 210, 220 222 and 224 tractors. To decrease the belt tension or to install or remove the belt, turn the adjusting crank clockwise.

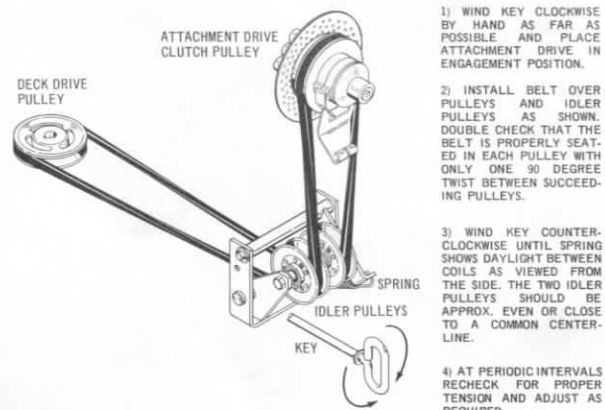

Figure 5.

3. Mower Blade Bolts:

Before operating the mower for the first time, check the bolts holding the blades. **THEY MUST BE TIGHT.** After the first 8 hours operating, check them again. Whenever the blades are removed, it is a good practice to install new lockwashers under the bolts, and again check tightness after next 8 hours operation.

4. Engine Maintenance:

Complete tractor and engine maintenance instructions are outlined on page 12 and 13 of your tractor Operator's Manual. When mowing, give particular attention to the areas which are affected by grass accumulation. Check and brush off the engine air intake screen and heat exchanger fins **DAILY.** Also check and clean the engine air cleaner element daily as explained on page 21 of your tractor manual. If mowing under particularly dry or dusty conditions a "Precleaner," part number KO237421, is available through your J I Case Dealer which fits over the regular element. See Figure 6. This precleaner can be washed out with soap and water as necessary which will extend the life of the dry element furnished with the tractor.

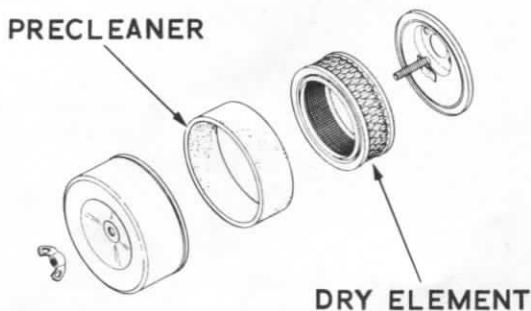

Figure 6.

5. Mower Fore-Aft Leveling Links: See Figure 7.

These links are adjusted at the factory for correct mower deck level. Clean cutting and minimum horsepower consumption are dependent upon the mower being level, fore and aft. If readjustment should become necessary, locate the tractor and mower on a level sur-

face and place the Height Selector Lever in the 2-1/2" setting before making adjustments. To raise the front of the mower, first loosen the outer nut on each link and then equally turn the inner nuts rearward. To lower the front of the mower, loosen the inner nut on each link and turn the outer nuts forward. Check blade heights as close to the front and rear edges of the mower as possible. Distance between the blades and the level surface should be the same at both front and rear edges of mower.

6. Mower Side To Side Leveling: See Figure 7.

Mower side to side leveling is adjusted at the factory. However, should readjustment become necessary it may be done by loosening the two carriage bolts on the right hand side that secure the gauge wheel carrier to the deck. The holes may be slotted if additional adjustment is required. After obtaining a level position, retighten the carriage bolts.

7. Mower Gauge Wheels: See Figure 7.

Remove the gauge wheels after each 10 hours of mowing and lubricate the bushings and axle bolts with chassis grease.

NOTE As an alternate to grease, the wheels can be oiled each four hours of operation. Make sure the oil penetrates to the inside of the bushings by holding the deck at a slanted angle while lubricating.

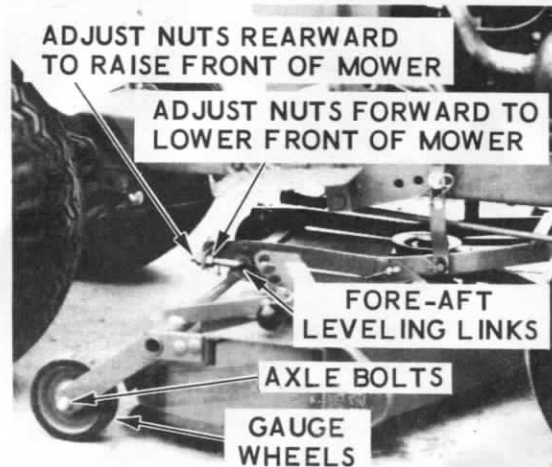

Figure 7.

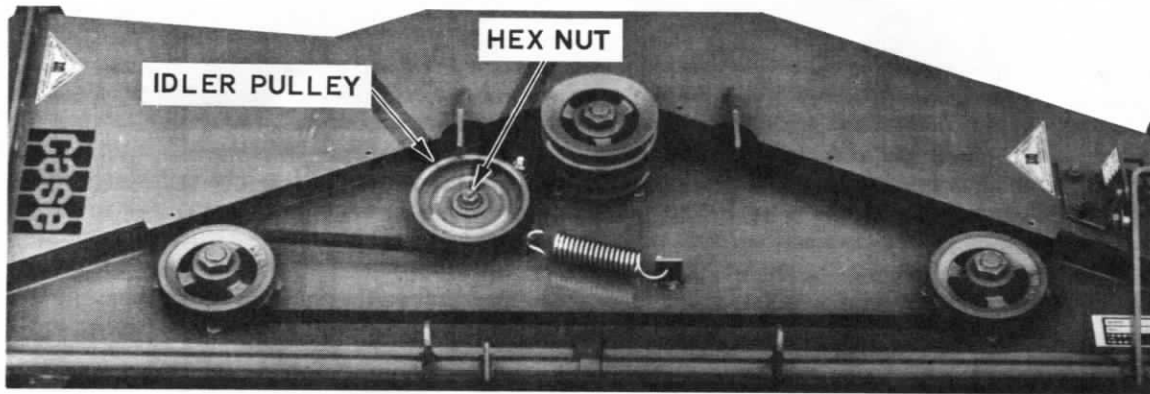

Figure 8.

8. Mower Deck Belt Replacement: See Figure 8.

The deck belt is automatically tensioned by a spring loaded idler pulley and does not require adjustment. If a new belt is installed, place it around the three spindle pulleys as illustrated. Place a 9/16" box wrench over the hex nut on the idler pulley and pivot the pulley towards the front of the mower until the belt can be easily placed over the back side of the idler as shown. Check to make sure the belt is not rolled or twisted before replacing covers.

9. Sharpening Blades: See Figure 9.

Check the mower blades periodically for nicks or dullness. Damaged or dull blades can cause a shattered rather than clean cut and brown areas may develop. The left picture, Figure 9, illustrates the correct angle at which to sharpen the blade cutting edges. If the cutting edge is sharpened at a blunt angle as shown in the right picture, the grass may also be shattered rather than cleanly cut.

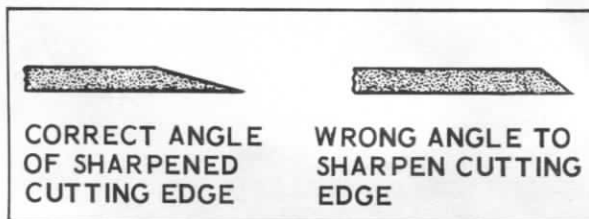

Figure 9.

10. Balancing Blades: See Figure 10.

After a blade is sharpened, check it for balance by inserting a dowel or bolt in the center hole and place between two level edges as shown in Figure 10. A balanced blade will center itself so the cutting edges are parallel with the edges.

CAUTION Unbalanced blades are a hazard and will cause premature wear and failure of bearings and spindles. If the blades cannot be balanced by resharpening them, replace with new blades.

11. Check and clean out the inside of the deck housing periodically. Remove any grass wrappings between the blade mounting plates and the spindle housings. Grass wrappings, if allowed to accumulate, may work their way under the bearings and damage the seals. Excessive grass accumulation in the deck housing will waste engine horsepower and cause plugging and streaking as well as corrosion.
12. Maintain the tires at equal and recommended pressures. Refer to tractor Operator's Manual.

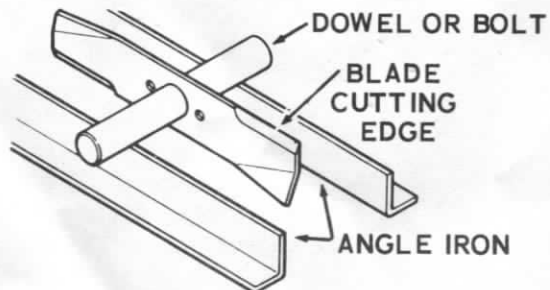
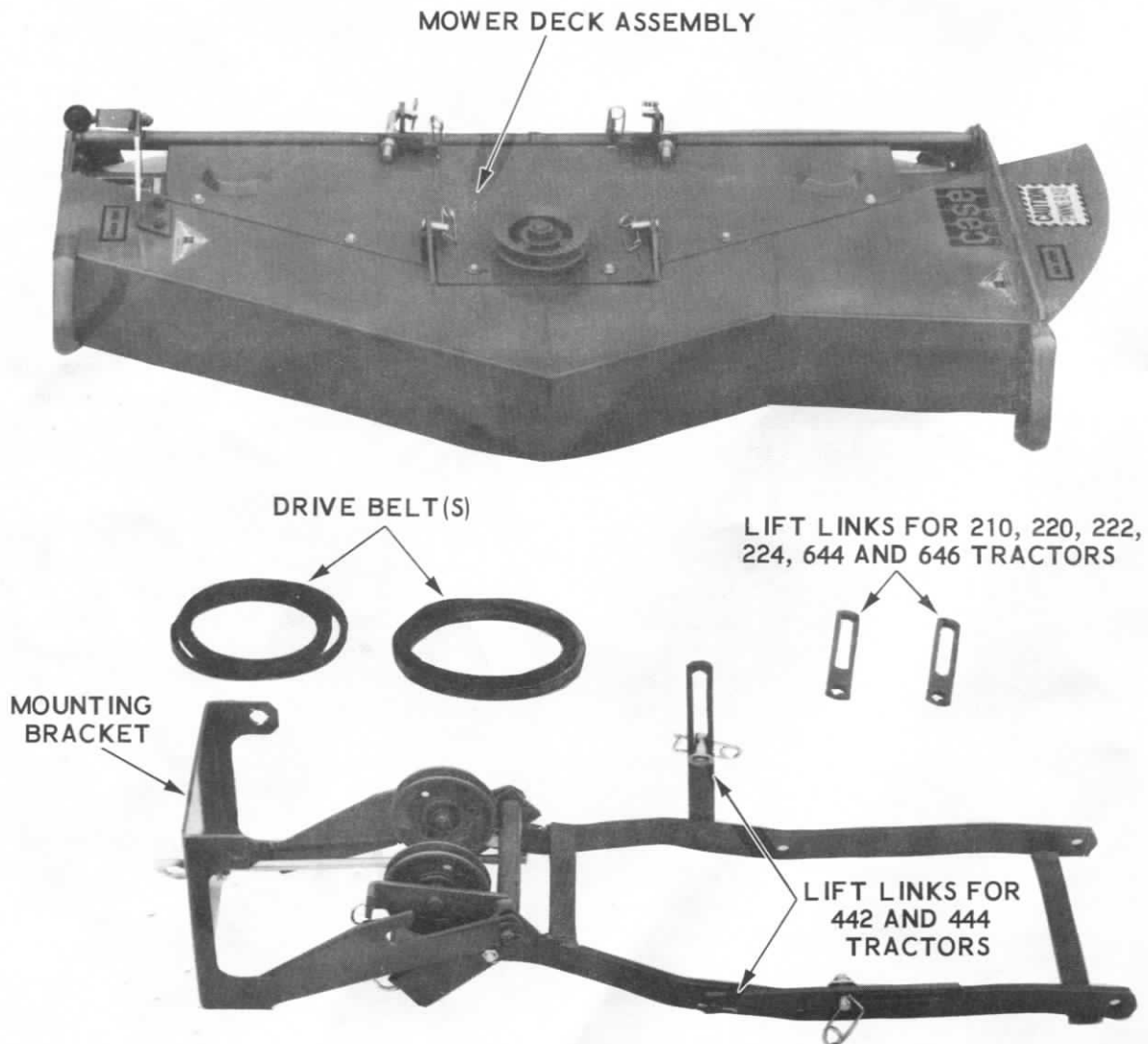

Figure 10.

INSTALLATION

- A. Locate the tractor on a level surface. Check tires for equal and recommended pressures as outlined on page 7 of the tractor operator's manual.
- B. Before installing the mower, lay out and check the individual components. The Model J44 or J46, 44" or 48" mower is illustrated in Figure 11 and includes an extra drive belt and lift links to permit their installation on either high or low clearance tractors without separate mounting kits. Since the Model J40, 38" mower is only intended for the Model 210, 220 or 222 tractors, it does not include the extra belt or links.
- C. The following installation sequence is the same whether the tractor is equipped with hydraulic or mechanical lift.



NOTE: ALL FOUR LIFT LINKS ARE PACKAGED LOOSE. ILLUSTRATION SHOWS THE LONGER LINKS INSTALLED FOR MOUNTING ON MODEL 442 AND 444 TRACTORS.

Figure 11.

1. The Model J40 mower is shipped with only two straight lift links and one drive belt since it is only recommended for the 210, 220, 222 and 224 tractors. Model J44 and J46 mowers are shipped with four straight lift links and two drive belts so they can be mounted on both high and low clearance tractors. See Figure 11 for identification of the lift links.

Model 210, 220, 222, 224, 644 and 646 - Assemble the two shorter links to the mounting bracket and secure with cotter pins. The slotted end of the links are to be later connected to tractor lift levers.

Model 442 and 444 - Assemble the two longer links to the mounting bracket as shown in Figure 12 and secure with cotter pins.

Model 446 - Assemble straight long lift link to left side and offset long lift link, part number C19652 to right side of mounting bracket and secure with cotter pins.

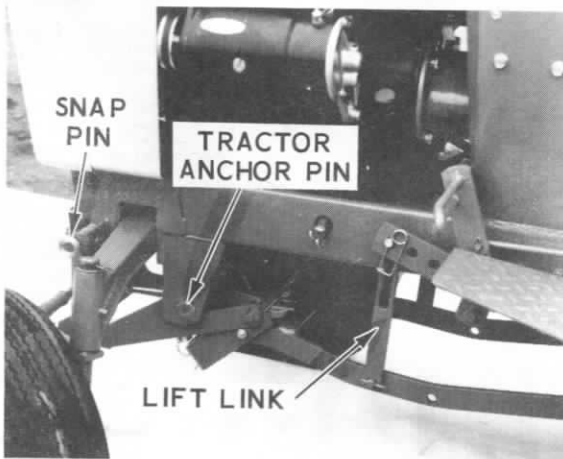

Figure 12.

2. Before attaching the mounting bracket on Model 210, 220, 222 or 224 tractors, turn the adjusting crank counterclockwise as far as possible to provide mounting clearance at the front axle. See Figure 13. This step is not required for the Model 442, 444, 644 and 646 tractors.

3. Position the mounting bracket under the front of the tractor and onto the anchor pins as shown in Figure 12. Raise the front of the bracket and release the snap pins to lock in place.

NOTE Model 644 and 646 - The mounting bracket is attached to these loaders with the two clevis pins and safety pins connected to each front side of the frame.

4. Place lift lever in the fully lowered position and connect the lift links to the front holes in the tractor lift lever.

With the tractor lift levers in the fully lowered position, place a plain washer on the clevis pins and install the lift links on the inside of the levers as shown in Figure 12. Secure the links with the safety pins at the outside.

5. Raise the lift lever into the transport position.

6. Slide the mower under the tractor from the right hand side and align the deck with attaching holes in the mounting bracket. Lower the mounting bracket to the mower deck.

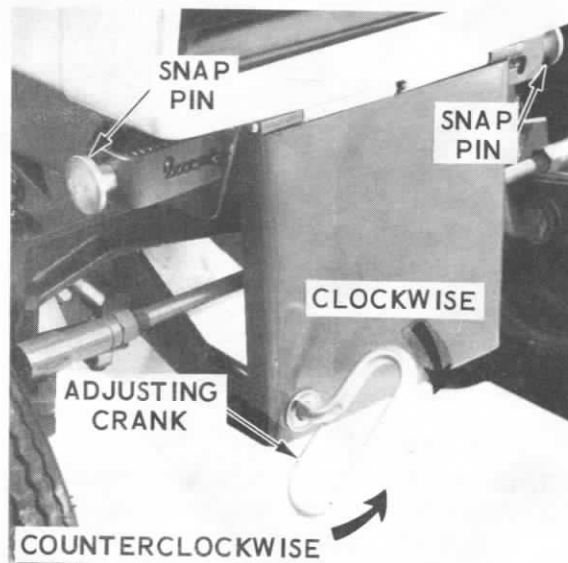

Figure 13.

7. See Figure 14. Install the fore-aft leveling links as illustrated and secure with safety pins.
8. Connect the mounting bracket to the tabs on the mower deck with the clevis pins and safety pins provided.

NOTE Lifting the mower deck upward slightly will aid in aligning the holes between the mounting bracket and deck tabs.

Two belts are packaged with Model J44, 44" and J46, 48" mowers. If mounting these mowers on Model 210, 220, 222, 224 or 644 tractors, use the shorter belt. The longer belt must be used when the mower is mounted on a Model 442, 444 or 446 tractor. If mounting the mower on the 646 wheel loader, drive belt, part number C13184 is required. This belt is not included with the mower.

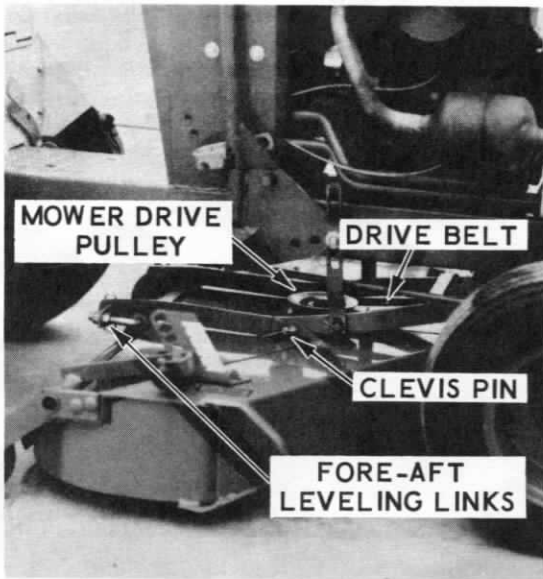

Figure 14.

9. See Figure 15. Pull the attachment drive lever to the "on" position. Raise the hood and remove the spark plug wire as a safety precaution. Insert

the drive belt in front of the idler pulleys, between the fan and heat exchanger and onto the attachment drive clutch pulley. Turn the adjusting crank clockwise until the belt can be easily placed around the idler pulleys and onto the mower drive pulley.

10. Check to make sure the belt is properly located in each pulley. Turn the adjusting crank counterclockwise to tension the belt until the two idler pulleys come into alignment. Put the attachment drive lever in to the "off" position and reconnect the spark plug wire.

IMPORTANT Before operating the mower, review and follow the recommendations outlined in the Adjustments and Maintenance section of this manual.

NOTE The J I Case Company reserves the right to make improvements in design or changes in specifications at any time without incurring any obligations to install them on units previously sold.

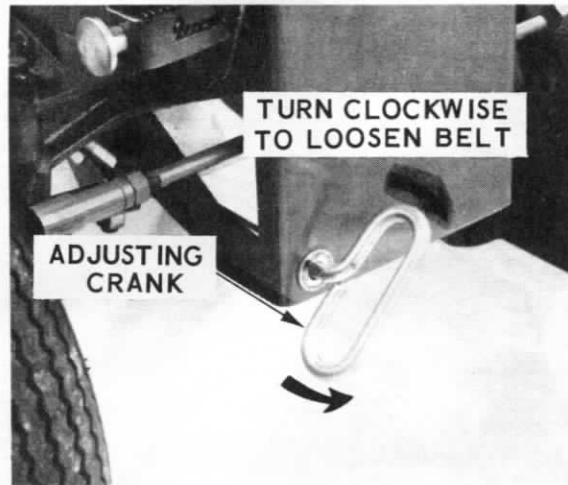

Figure 15.

022P

Book