



**ROTARY MOWER**

**J40, J44, J46**

**Operator's Manual No. 9-50552**

**J I Case**  
A Tenneco Company



## INTRODUCTION

This manual contains recommended operating procedures, safety rules, adjustments, maintenance information, assembly and mounting instructions. Read this manual carefully before operating your rotary mower.

Your J I Case Compact Tractor Dealer is well qualified to answer any further questions you might have concerning your rotary mower. Also, if the need should arise, his Service Department with factory trained technicians,

genuine Case replacement parts and the required facilities is in the position to provide proper repairs in the shortest time possible.

The definitions "Right, Left, Front, and Rear" as used throughout this manual relate to the tractor and rotary mower as the operator is seated facing forward in the normal operating position of the tractor.

<b>MOWER APPLICATION CHART</b>	
<u>MOWER MODEL</u>	<u>RECOMMENDED TRACTOR MODEL</u>
J-40	210, 220, 222
J-44	222, 224, 444, 446, 644, 646
J-46	224, 444, 446, 644, 646

<b>BELT APPLICATION CHART</b>	
<u>TRACTOR MODEL</u>	<u>BELT PART NUMBER</u>
210 All	C 18708
220 Prior to S/N 9656747	C 17050
220 S/N 9656747 and after	C 18708
222 PRIOR TO S/N 9658189	C 17050
222 S/N 9658189 and after	C 18708
224 All	C 18708
442 All	C 17052
444 Prior to S/N 9661261	C 17052
444 S/N 9661261 and after	C 18709
446 All	C 18709
644 Prior to S/N 9698343	C 17052
644 S/N 9698343 and after	C 21931 *
646 All	C 13184 *

\* Belt shipped with loader tractor

<b>SPECIAL INFORMATION</b>	
<u>TRACTOR MODEL</u>	
446 All	C 19652 special offset lift link supplied with tractor

<b>FOR INSTALLATION ON PRIOR MODEL TRACTORS</b>	
<u>TRACTOR MODEL</u>	<u>USE KIT</u>
220, 222 prior to S/N 9646800	H-38
442, 444 prior to S/N 9646800	H-39

## SAFETY RULES



This safety alert symbol indicates important safety messages in this manual. When you see this symbol, carefully read the message that follows and be alert to the possibility of personal injury or death.



Regard your rotary mower as a piece of power equipment and be sure this manual is read and understood by all who operate it.



**CAUTION:** Fill gas tank out of doors and avoid spilling gasoline. Do not fill tank with gasoline while smoking or while engine is running.



Maintain your tractor and rotary mower in top operating condition.



**CAUTION:** Never allow children or young teenagers to operate the tractor and rotary mower.



**CAUTION:** Clear the lawn or area to be mowed of sticks, stones or any hard objects which could come in contact with the blades and be hurled out the discharge opening.



**CAUTION:** Never get on or off the tractor while the mower is running.



**CAUTION:** Do not permit children or pets in the area while mowing and never direct the mower discharge at buildings, people, pets, windows or cars.



**CAUTION:** Operate in Low range and use extreme caution on slopes or inclines. Always back up, and drive down slopes. Mow in the forward and down direction only.



**WARNING:** Keep feet and hands away from discharge opening and make no repairs unless both the tractor engine and attachment drive are shut off and the key is removed from the tractor.



**CAUTION:** Be sure you know how to stop the tractor and mower at a moments notice.



**CAUTION:** Give complete and undivided attention to the job at hand.



**CAUTION:** Disengage attachment drive lever, stop engine and remove key and spark plug wire(s) before making adjustments.



**CAUTION:** Stop engine, disengage attachment drive, set parking brake and remove key when tractor is unattended.



**CAUTION:** Unbalanced blades are a hazard and will cause premature wear and failure of bearings and spindles. If the blades cannot be balanced by resharpening, replace them with new ones.



**CAUTION:** Do not allow anyone other than the operator to ride on the tractor.



**CAUTION:** Shut off engine, allow engine to cool and remove key and spark plug wire(s) before replacing mower drive belt.



**CAUTION:** Disengage attachment drive clutch when someone approaches or whenever the mower is in transport or the lifted position.



**CAUTION:** Spinning Blade - Keep hands and feet from under the mower deck to prevent injury.



**CAUTION:** Stop and inspect the mower for damage immediately after striking a foreign object and repair damage before restarting and operating the machine.



**WARNING:** Be sure that the attachment drive clutch is off, the engine is shut off, the key removed and the blades have stopped spinning before attempting to clean a plugged discharge chute.

## OPERATING CONTROLS

The principle components and controls of your rotary mower are identified in Figure 1 with the same description used throughout this manual.

All controls are located near the operator's position on the tractor. The mower blades are placed in motion by engaging the attachment drive clutch lever. The desired mowing height can be adjusted with the height selection lever.

Generally best performance is obtained with the transmission in Low range and the engine running  $\frac{3}{4}$  to full throttle. The throttle should be set as low as practical to obtain maximum fuel economy but high enough to prevent engine lug down or labor which could cause overheating and poor mowing. Adjust the tractor ground speed with the travel lever according to your mowing conditions.

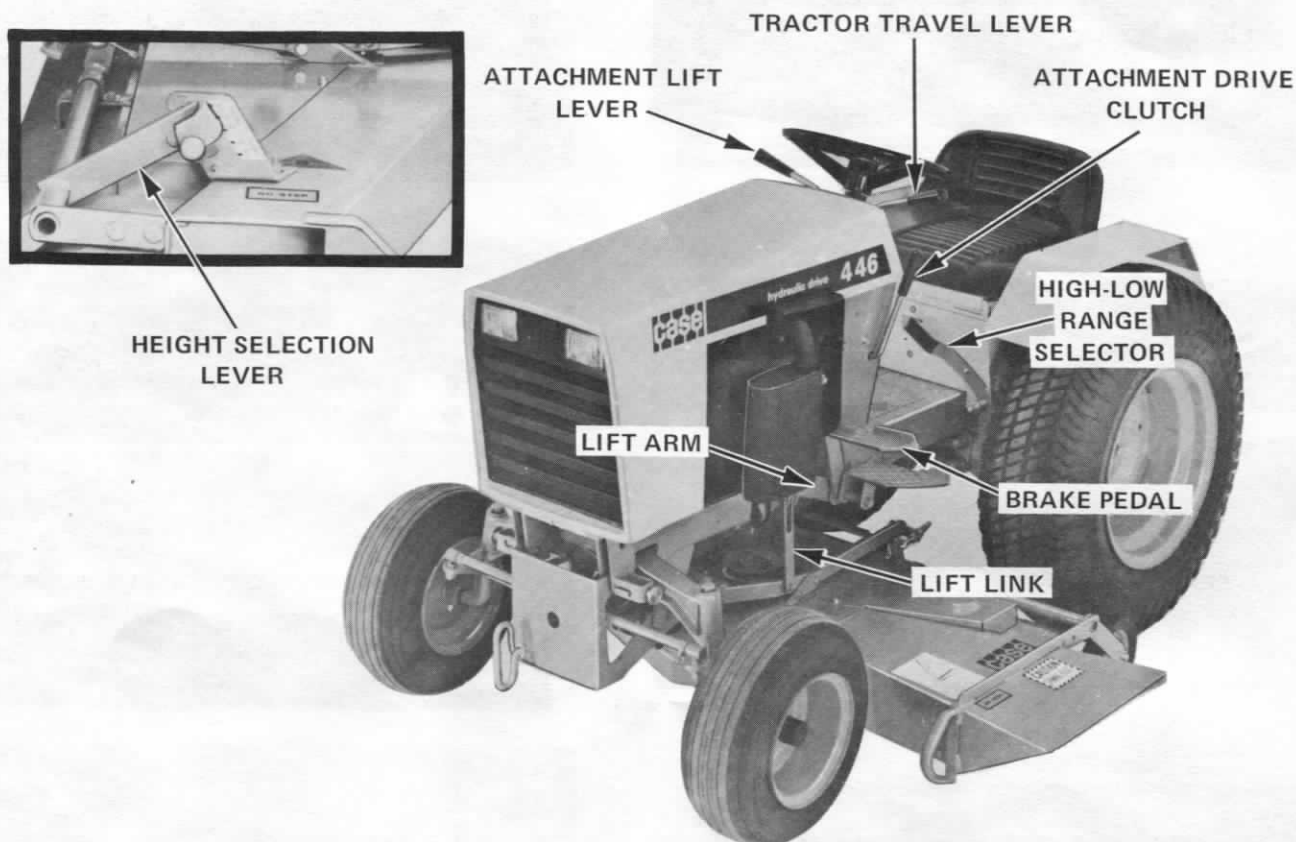

FIGURE 1 MODEL 446 WITH MODEL J-46 48" ROTARY MOWER

## OPERATION

1. Keep mower blades sharp and balanced as covered in the Maintenance Section of this manual.
2. Operate engine at approximately  $\frac{3}{4}$  to full throttle and regulate the ground speed Travel Lever according to mowing conditions. As a general rule, set the throttle as low as practical to obtain maximum fuel economy but high enough to avoid engine lug down or labor which could cause overheating and poor mowing performance. Unless grass is unusually light, always operate in "Low" speed range.
3. If grass is heavy and higher than normal, results can be improved by mowing twice. Make the first cut with the

mower set higher than normal; then repeat with the mower set at desired finished cut height. When mowing heavy grass, always discharge clippings away from the uncut area.



**WARNING:** Be sure that the attachment drive clutch is off, the engine is shut off, the key removed and the blades have stopped spinning before attempting to clean a plugged discharge chute.

4. Figures 2 and 3 illustrate two systems for mowing. If the grass is high or heavy, always mow to throw the clippings away from the uncut area. Figure 2. If the grass is light and more thorough mulching is desired, discharge the clippings toward the center of the uncut area, Figure 3. When mowing in this manner, a final strip of mulched clippings about three to four feet wide will remain near the center of the lawn. This can be easily raked up to leave a well groomed appearance.

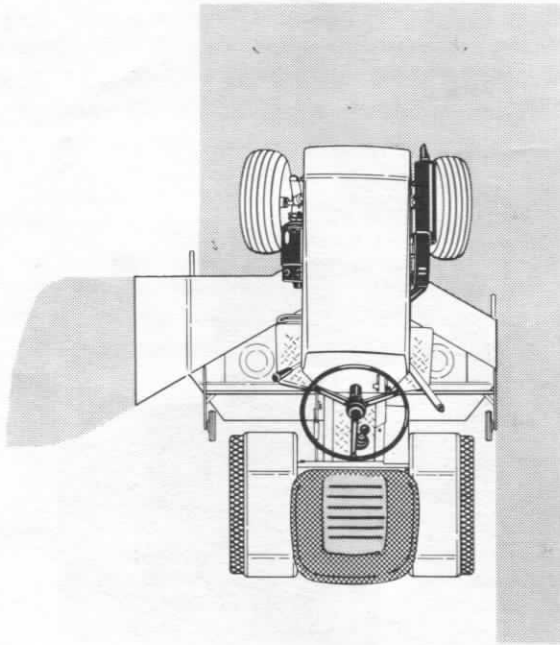

FIGURE 2

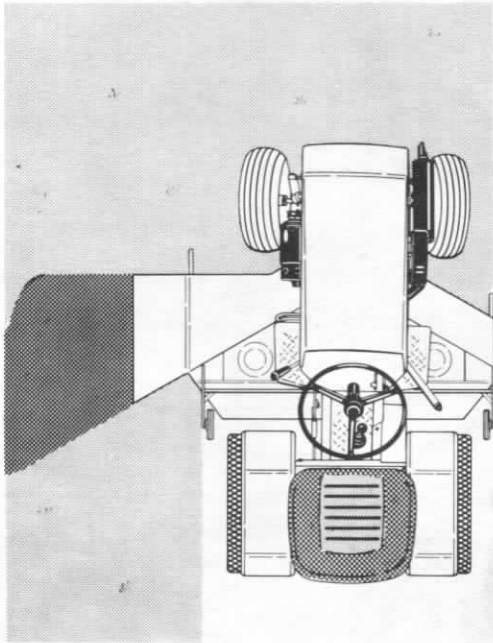

FIGURE 3

5. Trimming will be neater and closer by using the right side of the mower since the clippings will be discharged away from the object. Also the safety shield over the discharge opening prevents mowing as close to objects.



**CAUTION:** Never get on or off the tractor while the mower is running.

6. Do not step on the mower deck when getting on or off the tractor. If mounting the tractor from the right side, place your right foot on the right foot rest, your right hand on steering wheel and left hand on the seat back and step onto the tractor, swinging your left foot through between the steering wheel and seat.

When mounting from the left side, start with your left foot on the left foot rest, your left hand on steering wheel and right hand on seat back and step onto tractor swinging your right foot through between steering wheel and seat. Dismount the tractor using the reverse of the above procedures.

7. The mechanical or hydraulic lift lever is used to raise the mower into transport and to lower it into cutting position. A slight pulling pressure on the mechanical lever will permit the release button to be more easily depressed.

Lower the hydraulic lift until the lift arms are positioned midway in the lift link slots. This will allow the mower deck and gauge wheels to follow the contour of the ground. Do not place the hydraulic lift control lever in the hydraulic float position when mowing.

The Height Selection settings are explained in the adjustments section of this manual.

8. Always engage tractor and mower drive systems smoothly.



Be certain whoever operates the mower has read and understands the Safety Rules in the front of this manual.

## ADJUSTMENTS



**CAUTION:** Disengage attachment drive lever, stop engine and remove keys and spark plug wire(s) before making adjustments.

### 1. Height Selection Lever. See Figure 4.

The mower cutting height is adjustable from 1½" to 3½" in ½" increments.

To change cutting height:

- a. Raise mower into transport position to relieve weight from the height selection lever.
- b. Pull outward on the height selection knob.
- c. Move the lever up or down to the desired height.
- d. Push knob into the hole selected.

### 2. Gauge Wheels. See Figure 4.

Always operate the mower with the gauge wheels on the ground and all weight off the mower lift links to obtain a level and uniform cut. Be sure the gauge wheels clear the ground when transporting the mower.

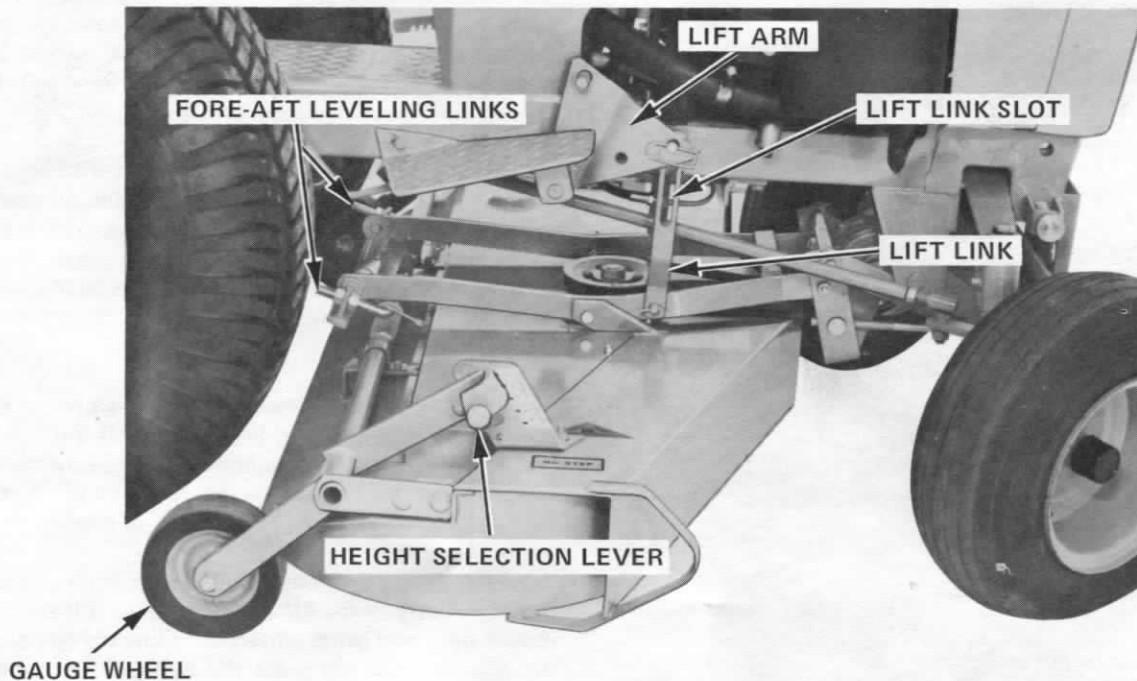

FIGURE 4 ADJUSTMENTS

### 3. Drive Belt Tension. See Figure 5.

The mower drive belt is properly tensioned when the front idler spring has 1/8 inch (approximately the thickness of two nickels) gaps between its coils.

**IMPORTANT** Check and adjust the tension on a new belt after the first 20 minutes and the next hour of mowing since it is normal for a belt to stretch slightly during its initial run-in period.

To increase the belt tension, turn the adjusting crank in a counterclockwise direction while facing the front of the tractor.

To decrease the belt tension or to install or remove the belt, turn the adjusting crank clockwise.

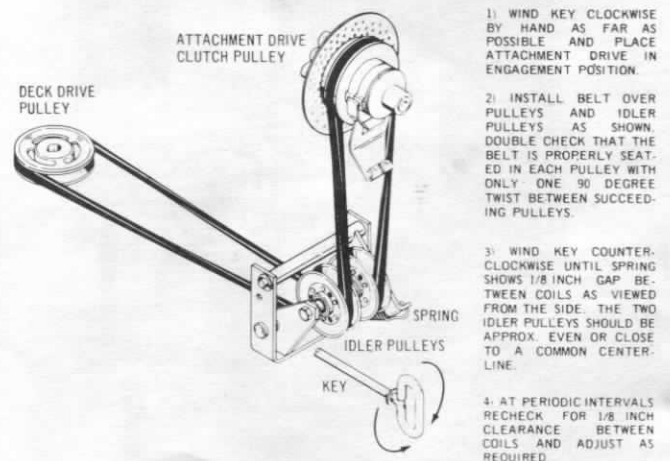

FIGURE 5

4. Mower Fore-Aft Leveling Links. See Figure 6.

Clean cutting and minimum horsepower consumption are dependent upon the mower being level fore and aft.

To adjust, locate the tractor and mower on a level surface such as your garage floor and place the Height Selection lever in the 2½" setting. Lower the mower into the cutting position.

To raise the front of the mower, first loosen the rear nut on each link and then equally turn the front nuts rearward.

To lower the front of the mower, loosen the front nut of each link and turn the rear nuts forward.

Position blades so that they are parallel to the tractor frame (fore and aft line) before measuring clearance.

Check blade heights as close to the front and rear edges of the mower blades as possible. Be sure to tighten both front and rear nuts when checking blade height.

Adjust the leveling links until the distance between the blade tips and the level surface is the same at both the front and rear of the mower. The forward tip may be slightly lower than the rearward tip. Never permit the rearward tip to be lower than the forward tip. (This doubles power consumption in mowing)!

5. Mower Side to Side Leveling. See Figure 6.

Mower side to side leveling is adjusted at the factory. Should readjustment become necessary, it may be done by loosening the two carriage bolts on the right hand side that secures the gauge wheel carrier to the deck. The holes may be slotted if additional adjustment is required. After obtaining a level position, retighten the carriage bolts.

Side to side leveling should be done on a level surface, such as your garage floor with the height selection lever in the 2½" setting and the mower lowered into the cutting position. Be sure the mower is level fore and aft before checking side to side level.

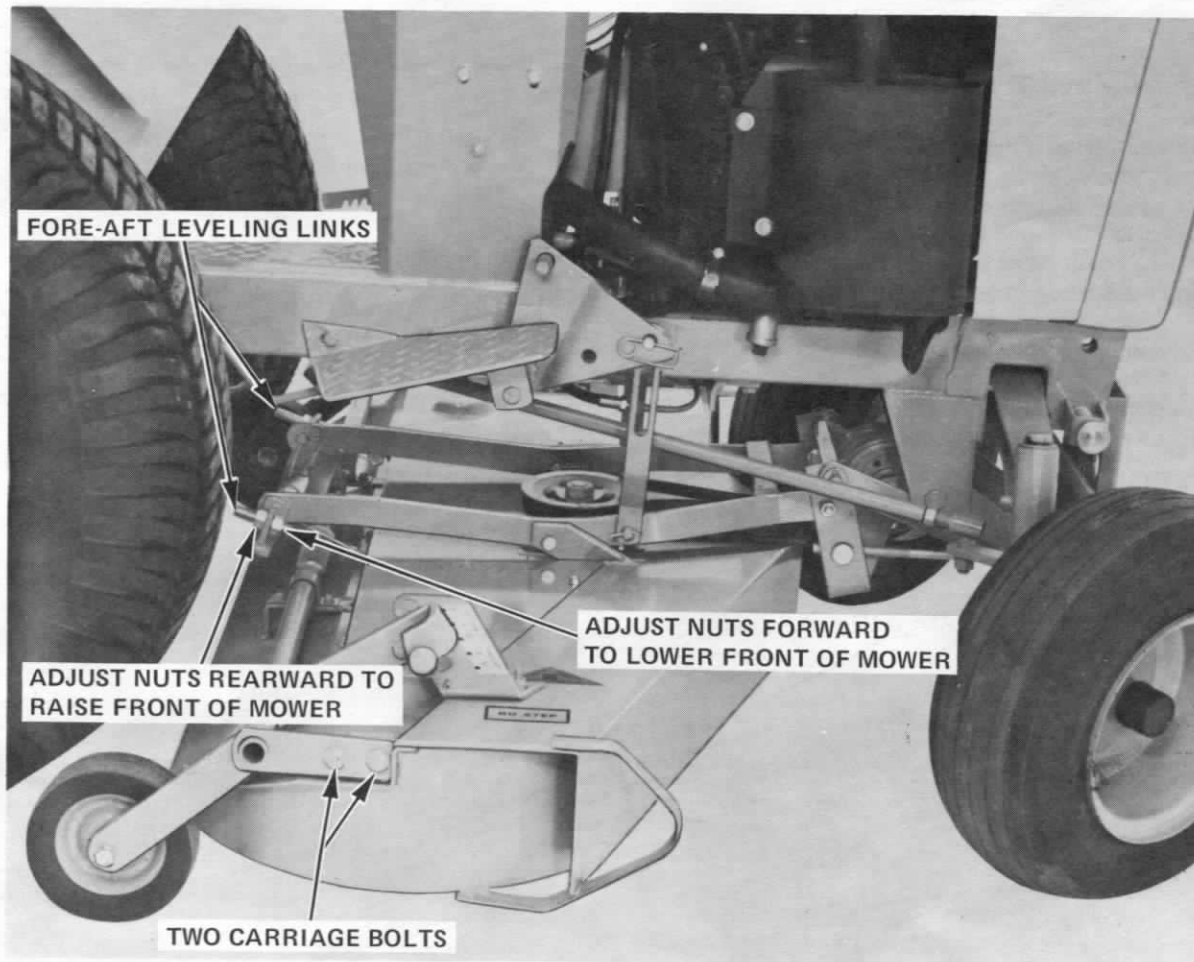

FIGURE 6 ADJUSTMENTS



## MAINTENANCE



**CAUTION:** Disengage attachment drive lever, stop engine and remove keys and spark plug wire(s) before making adjustments.

### 1. Mower Blade Bolts. See Figure 7.

Before operating the mower for the first time, check the bolts holding the blades. They must be tight. After the first 8 hours of operation, check them again. Whenever the blades are removed, it is good practice to install new lockwashers under the bolts, and again check tightness after the next 8 hours of operation.

### 2. Bent Blades. See Figure 7.

Check for bent blades before mounting the mower and after impact. Blade tips should be within  $\frac{1}{4}$  inch of the same horizontal plane. Align all six blade tips, two at a time as shown in Figure 7 to determine this. Mowing with bent blades will cause missed strips and a poor mowing job. Bent blades should be replaced immediately.

### 3. Mower Gauge Wheels. See Figure 8.

Remove the gauge wheels after each 10 hours of mowing and lubricate the bushings and axle bolts with chassis grease. As an alternate to grease, the wheels can be oiled after each four hours of operation. Make sure the oil penetrates to the inside of the bushings by holding the deck at an angle while lubricating.

### 4. Mower deck belt replacement. See Figure 8.

The deck belt is automatically tensioned by a spring loaded idler pulley and does not require adjustment.

Install a new belt in the following manner:

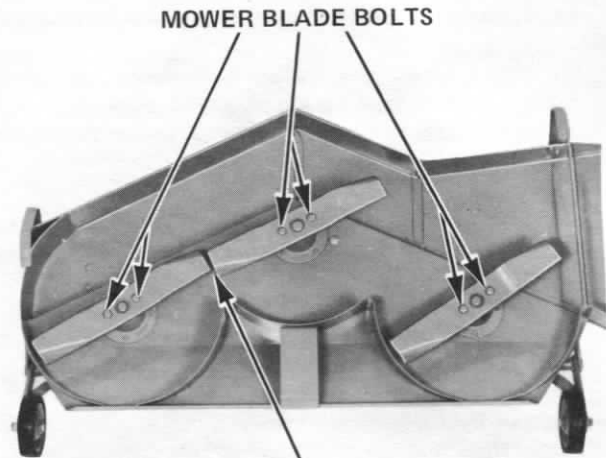

TIPS SHOULD BE WITHIN  $\frac{1}{4}$ " OF SAME HORIZONTAL PLANE.

FIGURE 7

- Remove the deck belt guard.
- Relax the idler pulley tension by pivoting it towards the front of the deck with a  $\frac{9}{16}$ " box wrench placed on the hex nut.
- Remove the old belt.
- Place the new belt around the 3 spindle pulleys and idler.
- Rotate system by hand to check for free operation and idler take up.
- Replace deck belt guard.

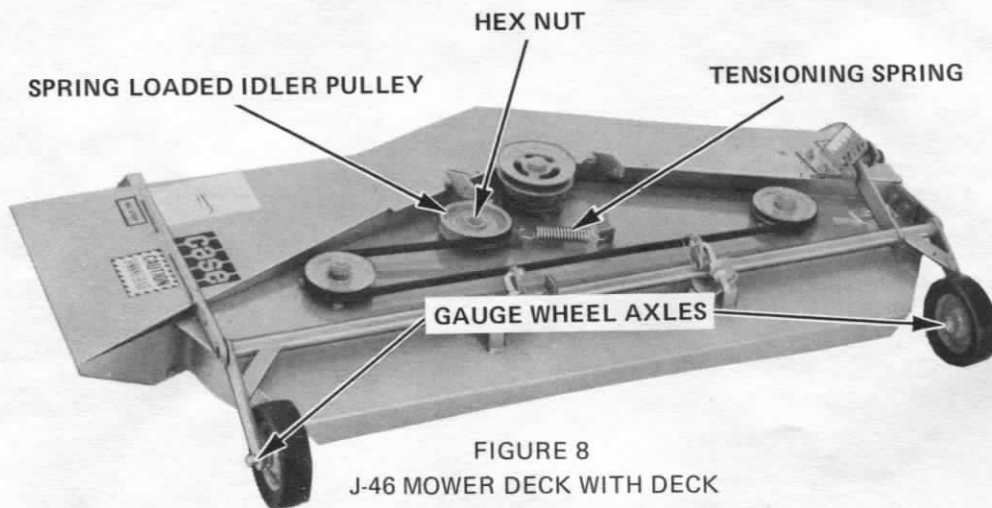

FIGURE 8  
J-46 MOWER DECK WITH DECK  
BELT GUARD REMOVED FOR CLARITY

5. Sharpening Blades. See Figure 9.

With the engine shut off and after the blades have stopped spinning, check the mower blades periodically for nicks or dullness. Damaged, dull or improperly sharpened blades can cause a shattered, rather than, clean cut and brown areas of grass may develop. Refer to Figure 9 for the correct sharpening angle.

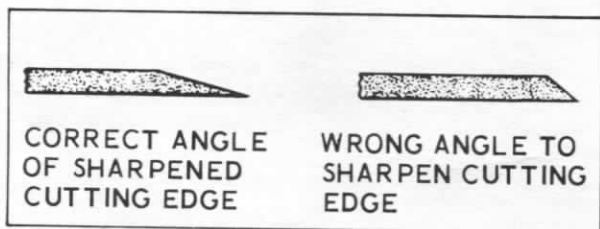

FIGURE 9

6. Balancing Blades. See Figure 10.

After a blade is sharpened, check it for balance by inserting a dowel in the center hole and place between two level edges as illustrated. A balanced blade will center itself so the cutting edges are parallel with the level edges.

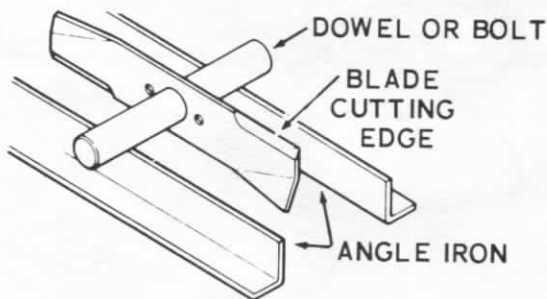

FIGURE 10

**CAUTION:** Unbalanced blades are a hazard and will cause premature wear and failure of bearings and spindles. If the blades cannot be balanced by sharpening, replace them with new ones.

7. Cleaning the mower deck.

With the engine shut off and after the blades have stopped spinning, check and clean out the inside of the deck housing periodically. Remove any grass wrappings between the blade mounting plates and spindle housings. Grass wrappings, if allowed to accumulate, may work their way under the bearings and damage the seals. Excessive grass accumulation in the deck housing will waste horsepower and cause plugging and streaking, as well as, corrosion.

8. Tractor and Engine Maintenance. See Figure 11.

Complete tractor and engine maintenance instructions are outlined in your tractor Operator's Manual. When mowing, give particular attention to areas which are affected by grass accumulation.

Check and brush off the engine air intake screen and heat exchanger fins daily. Also check and clean the engine air cleaner element daily. If mowing under particularly dry or dusty conditions, a precleaner which fits over the regular element is available from your J I Case Dealer. This precleaner can be washed out with soap and water as necessary and will extend the life of the dry element furnished with the tractor.

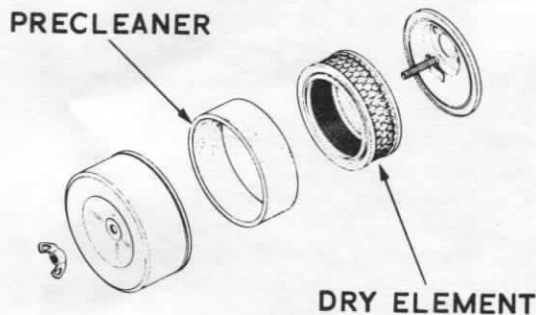

FIGURE 11

9. Tire Pressure.

Maintain the tires at equal and recommended pressures. Refer to your tractor Operator's Manual.

## INSTALLATION

### I. ASSEMBLY

1. Before assembling the mower, lay out and check the individual components. See Figure 12.

The J-40 Mower is shipped with one drive belt and one set of lift links since it is intended for use on low clearance (200 series) tractors only.

The J-44 and J-46 Mowers are shipped with two drive belts and two sets of lift links since they may be mounted on either low or high clearance (200, 400 or 600 series) tractors.

2. Select the appropriate belt using application chart on page 3. The belt part number is stamped into the outer covering of the belt. Select the two short lift links if installation is to be on a low clearance (200 or 600 series) tractor.

Select the two long lift links if the installation is to be on a Model 444.

Select one long lift link and special link P/N C 19652 (supplied with tractor) if the installation is to be on a Model 446.

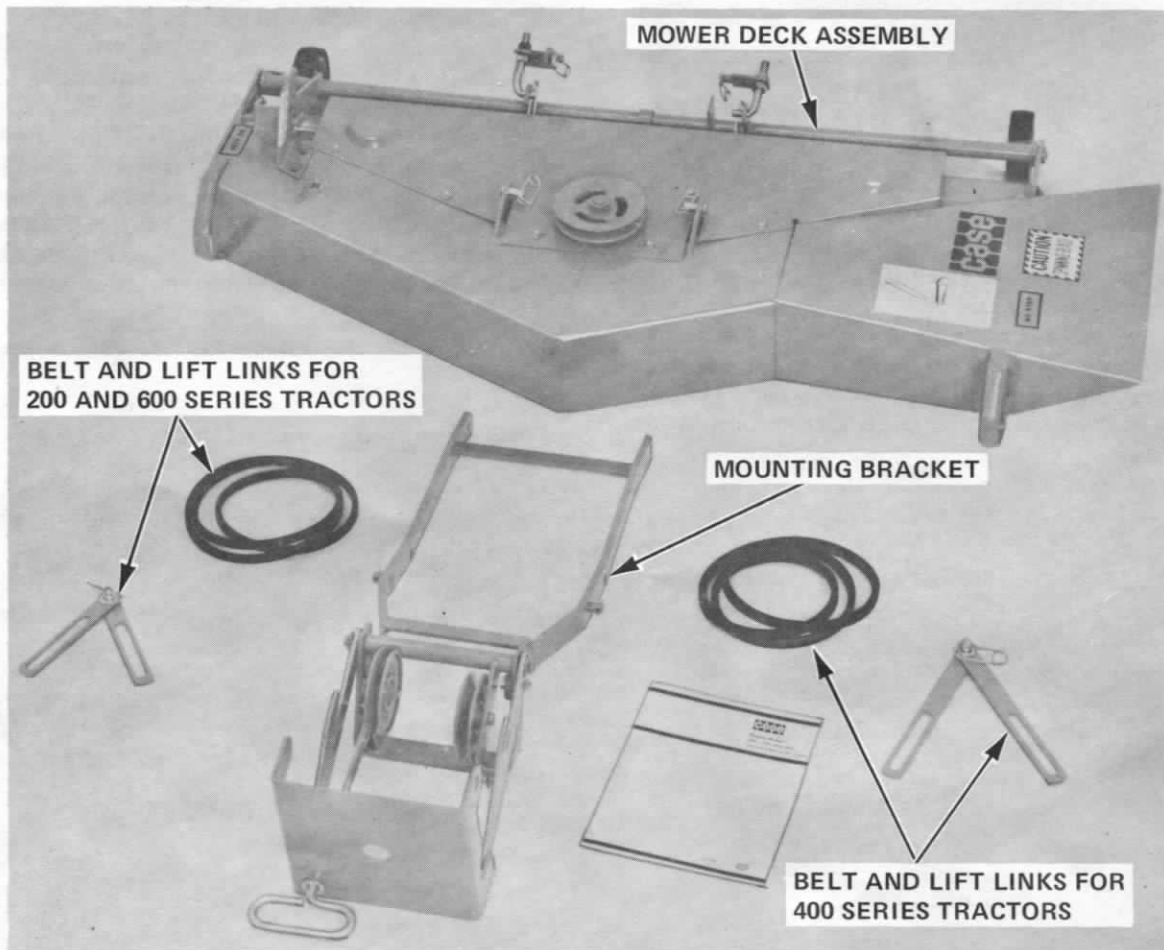

FIGURE 12 MODEL J-46 ROTARY MOTOR - DISASSEMBLED

3. Assemble the lift links to the mounting bracket and secure with cotter keys as shown in Figure 13.

The special link P/N C 19652 for the Model 446 (supplied with tractor) should be installed on the right hand side.

The slotted end of the links will be connected to the tractor life arms when mounted.

#### NOTE

Do not preassemble the mounting bracket to the mower deck as shown in Figure 13. It is easier to install the mounting bracket to the tractor first and then attach the mower deck to it.

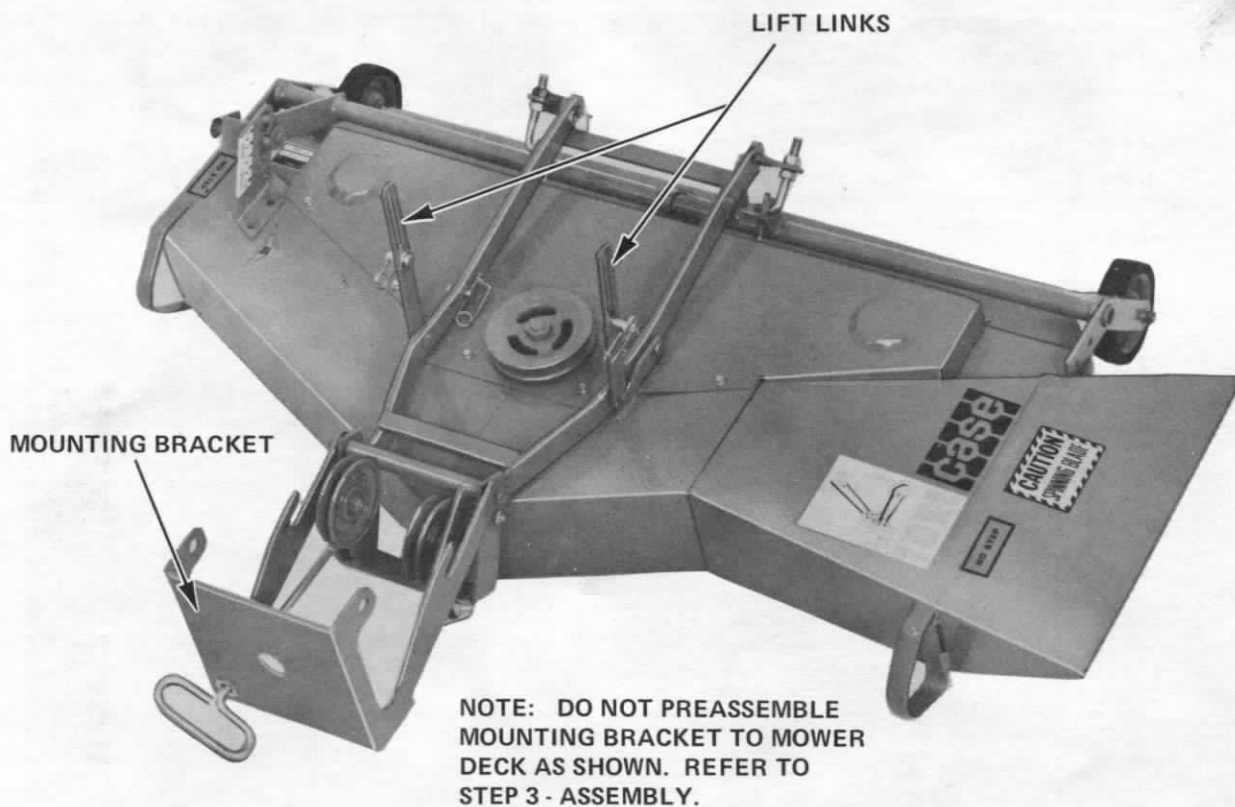

FIGURE 13 MODEL J-46 ROTARY MOWER - ASSEMBLED

## II. MOUNTING

1. Locate tractor on a level surface. Check tires for equal and recommended pressures as found in your tractor Operator's Manual.
2. Before attaching the mounting bracket, turn the adjusting crank counterclockwise as far as possible to provide mounting clearance at the front axle. Refer to Figure 14.

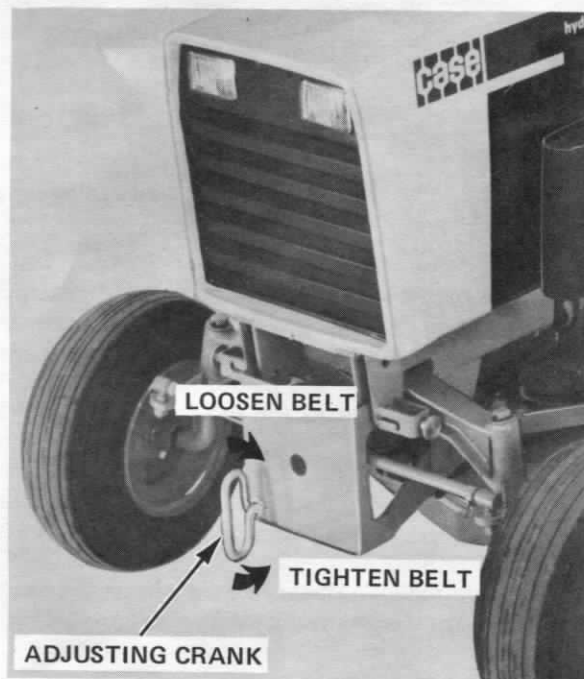

FIGURE 14 BELT ADJUSTMENT

3. Position the mounting bracket under the front of the tractor and onto the anchor pins as shown in Figure 15. Raise the front of the bracket and release the snap fast pins to lock in place.

**NOTE** Model 644 and 646 - The mounting bracket is attached with the two clevis pins and safety pins connected to each front side of the frame.

4. Lower the lift arms fully. Position the lift links on the inside of the lift arms. Put a plain washer on each clevis pin and install in the front hole of the lift arm from the inside. Secure the links with the safety pins at the outside. Refer to Figure 15.

5. Raise the lift arms into the transport position.

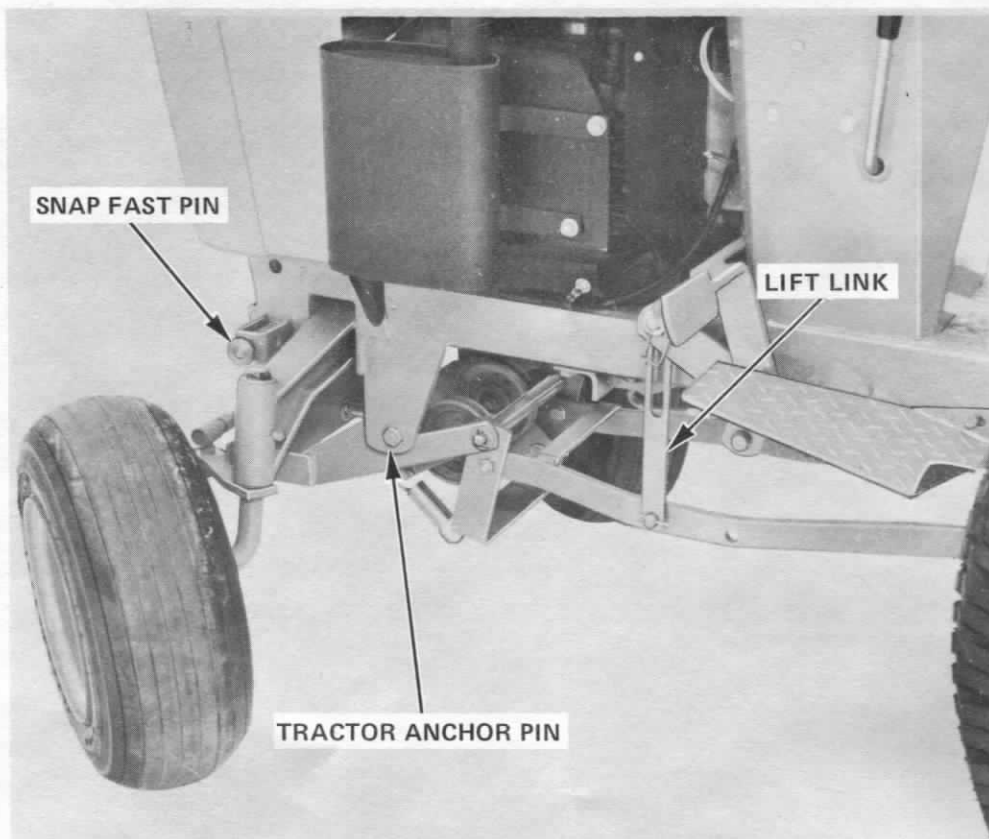

FIGURE 15 MOUNTING THE J-46 MOWER MOUNTING BRACKET

6. Place the height selection lever in the 1½" setting to gain additional clearance and slide the mower under the tractor from the right hand side and align the deck with the attaching holes in the mounting bracket. Lower the mounting bracket to the mower deck. Refer to Figure 16.
7. Install the Fore-Aft leveling links to the mounting bracket as illustrated in Figure 16.
8. Connect the mounting bracket to the tabs on the mower deck with the clevis pins and safety pins provided.

**NOTE** Lifting the mower deck upward slightly will aid in aligning the holes between the mounting bracket and deck tabs.

9. With the engine shut off, key removed, and cool to the touch, engage the attachment drive lever. Raise the hood and remove the spark plug wire(s) for safety. Insert the drive belt in front of the idler pulleys, between the fan and heat exchanger and onto the attachment drive clutch pulley. Turn the adjusting crank clockwise until the belt can be easily placed around the idler pulleys and onto the mower drive pulley.



**CAUTION:** Shut off engine, allow engine to cool and remove key and spark plug wire(s) before replacing mower drive belt.

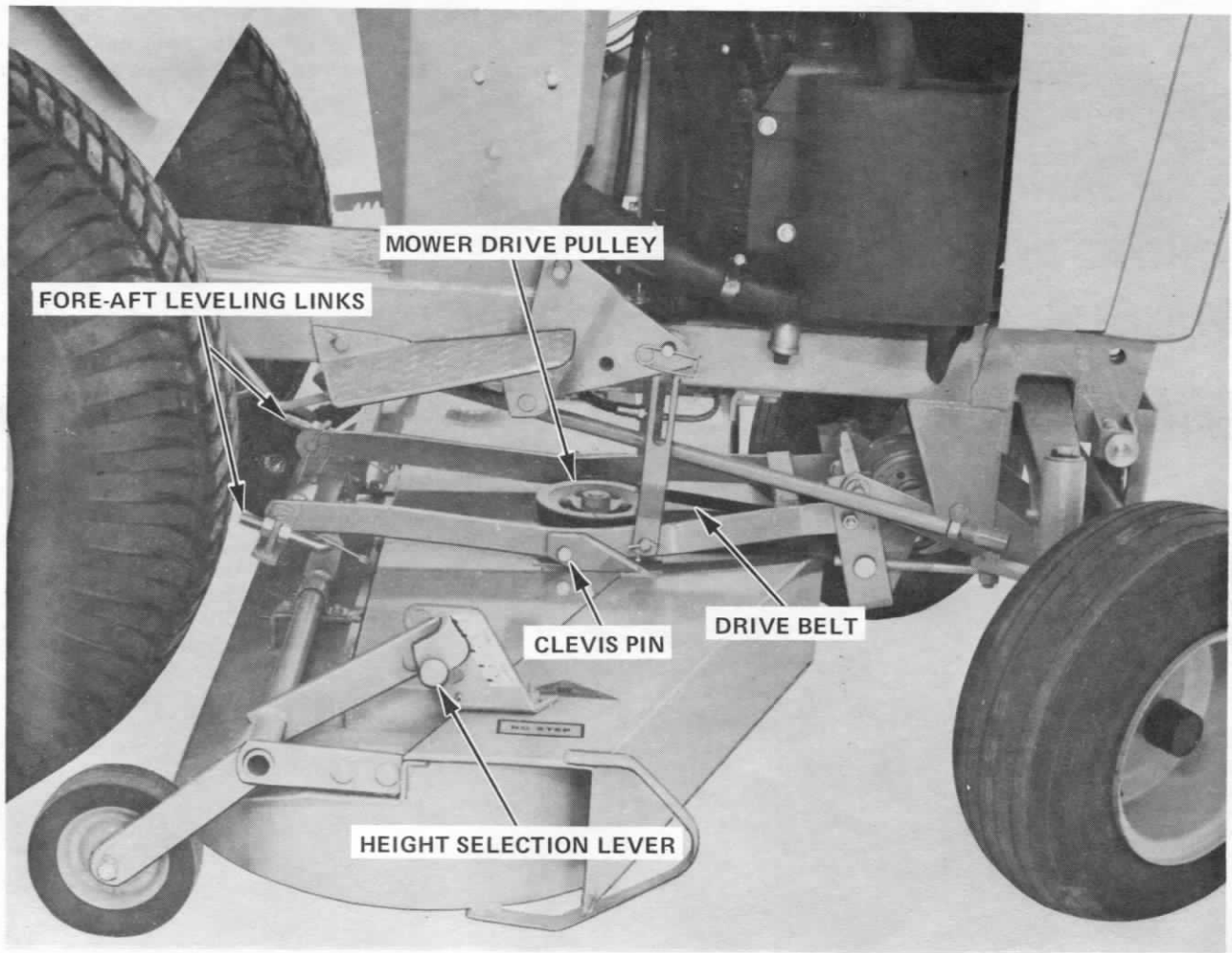

FIGURE 16 MOUNTING THE J-46 MOWER DECK

10. Check to make sure the belt is properly located in each pulley. Turn the adjusting crank counterclockwise to tension the belt until the idler spring coils open 1/8 inch (approximately the thickness of two nickels. See Figure 5 and 14.) Disengage the attachment drive lever and reconnect the spark plug wire(s).

**IMPORTANT** Before operating the mower, review and follow the recommendations outlined in the adjustments and Maintenance section of this manual.

The J I Case Company reserves the right to make improvements in design changes in specifications at any time without incurring any obligations to install them on units previously sold.

Printed In U.S.A.