



HOLDING VALVE
L7, L9, LL9 AND M9
Operator's Manual No. 9-51132

J I Case
A Tenneco Company





This Safety Alert Symbol Indicates Important Safety Messages In This Manual When You See This Symbol Carefully Read The Message That Follows and Be Alert To The Possibility Of Personal Injury Or Death

IF THIS MACHINE IS USED BY AN EMPLOYEE OR IS LOANED OR RENTED, MAKE ABSOLUTELY CERTAIN THAT THE OPERATOR(S), PRIOR TO OPERATING:

- 1. IS INSTRUCTED IN SAFE AND PROPER USE.**
- 2. REVIEWS AND UNDERSTANDS THE MANUAL(S) PERTAINING TO THE MACHINE.**

751253



WARNING

BEFORE STARTING ENGINE

**STUDY OPERATOR'S MANUAL SAFETY MESSAGES
READ ALL SAFETY SIGNS ON MACHINE
CLEAR THE AREA OF OTHER PERSONS**

**LEARN & PRACTICE SAFE USE OF
CONTROLS BEFORE OPERATING**

IT IS YOUR RESPONSIBILITY TO UNDERSTAND AND FOLLOW MANUFACTURER'S INSTRUCTIONS ON MACHINE OPERATION, SERVICE, AND TO OBSERVE PERTINENT LAWS AND REGULATIONS. OPERATOR AND SERVICE MANUALS MAY BE OBTAINED FROM YOUR EQUIPMENT DEALER.

HOLDING VALVE APPLICATION

HOLDING VALVE MODEL	TRACTOR MODEL AND P.I.N.
L-7	220, 222, 224 – P.I.N. 9646800 and after
L-9	442 – P.I.N. 9646800 and after 444 – P.I.N. 9646800 to 9766839 446 – P.I.N. 9646800 to 9770164
LL-9	644, 646, 646B – P.I.N. 9646800 and after
M-9	444 – P.I.N. 9766840 and after 446 – P.I.N. 9770165 and after 448 – P.I.N. 9774000 and after

INTRODUCTION

The addition of this Holding Valve to the standard hydraulic drive system provides a Hill Holding Feature over the full range of travel speed in both Forward and Reverse.

The single hill holding speed in Forward and Reverse identified as "Retard" by the travel control lever decal still functions.

With the Holding Valve installed, the "Retard" position may be used for slow travel speeds if desired but is not required for down hill travel.

The Tractor Operator's Manual Safety Messages for hillside operation must be followed.



WARNING: Improper operation of your tractor on hillsides and slopes can be dangerous. Avoid improper operation! Read and follow the instructions given in the section titled "Hillside Operation" in your tractor operator's manual before you operate your tractor.

INSTALLATION

HYDRAULIC SYSTEM FLUSHING PROCEDURE

The hydraulic system must be flushed before installation of the Holding Valve Kit.

1. Locate tractor on clean, level surface.
2. Place a clean drain pan of about 2 gallon capacity under travel control valve drain plug.

NOTE: Drain pan must be thoroughly washed as oil may be strained and reused during flushing procedure.

3. Remove 1/4" NPT hex plug (drain plug) from inlet of travel control valve.
4. Place two speed transaxle in neutral.
5. Start and run engine at low idle. Oil will be pumped out the drain hole.
6. Cycle travel control lever from Forward to Reverse and cycle hydraulic lift from raise to lower several times while oil is pumping out. Cycle tiller if installed. (For loaders - place travel lever in Forward and depress travel pedal, then in Reverse and depress travel pedal. Also, cycle loader bucket circuits.)
7. Shut tractor off the instant the oil stream begins to break or spurt and have air mixed with it.

IMPORTANT: Tractor engine must be stopped immediately when draining oil stream begins to break and have air mixed with it. Serious damage to hydraulic pump will occur if engine is allowed to run with low hydraulic oil level.

8. Strain oil through several folds of cheese cloth and return to tractor reservoir.
9. Repeat process until all visible contaminants are removed.

NOTE: If oil is discolored or severely contaminated on used units, fill with new oil and continue flushing procedure.

10. Leave hydraulic system drained to install Holding Valve Kit.
11. New units can be refilled with the original oil (after straining). Used units must be filled with new oil after completion of Holding Valve installation.
12. Replace drain plug.

INSTALLATION PROCEDURE

1. Support left rear axle securely on jack stand. Tubes between travel control valve and hydraulic motor must be accessible.
2. Remove left rear wheel.
3. Remove both valve to motor tubes.
4. Remove fittings from travel valve and two fittings from hydraulic motor.

On 400 series tractors and tractors with hydraulic PTO installed, the UPPER ELBOW on the hydraulic motor will not rotate.

To remove this elbow, saw through the elbow and then remove the remaining stub.

Use care not to allow metal filings to enter the hydraulic motor work ports.

5. Install two fittings 7/8" o-ring x 5/8" tube (1) to travel valve. Tighten securely.
6. Install one fitting 7/8" o-ring x 5/8" tube (1) to upper hydraulic motor port. Tighten securely.
7. Install one fitting 7/8" o-ring x 1/2" straight pipe swivel femal (5) to lower hydraulic motor port. Tighten securely.

NOTE: Connect all the following parts loosely. Tighten only after all parts are installed.

8. Holding Valve ports are stamped:
"V" for travel valve
"M" for hydraulic motor
9. Position Holding Valve with pre-assembled elbow in-board and loosely connect straight fitting (4) to swivel fitting (5) at lower motor port.
10. Loosely install tube (6) from elbow (3) to upper motor port.
11. Connect tubes (7) and (8) from straight fittings (2) to travel valve ports as illustrated.

NOTES: Tubes (7) and (8) connect differently on tractor and loaders. Refer to the appropriate illustration for your model.

12. Tighten all fittings.
13. Fill hydraulic system to proper level.

HYDRAULIC MOTOR

TRAVEL VALVE

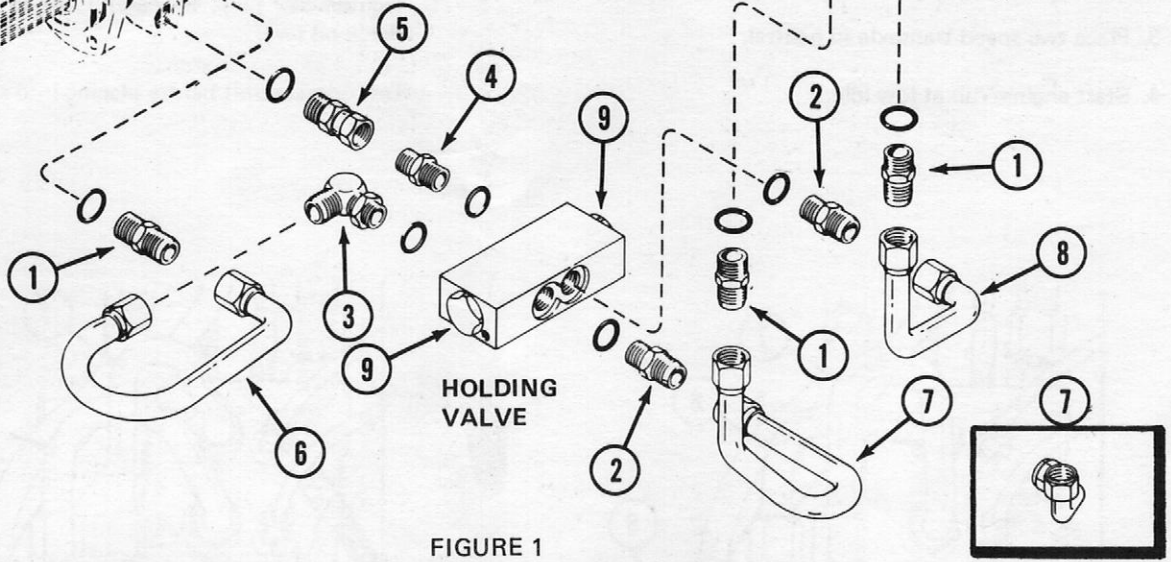

FIGURE 1
L7, L9 AND M9 INSTALLATION ON TRACTORS

HYDRAULIC MOTOR

TRAVEL VALVE

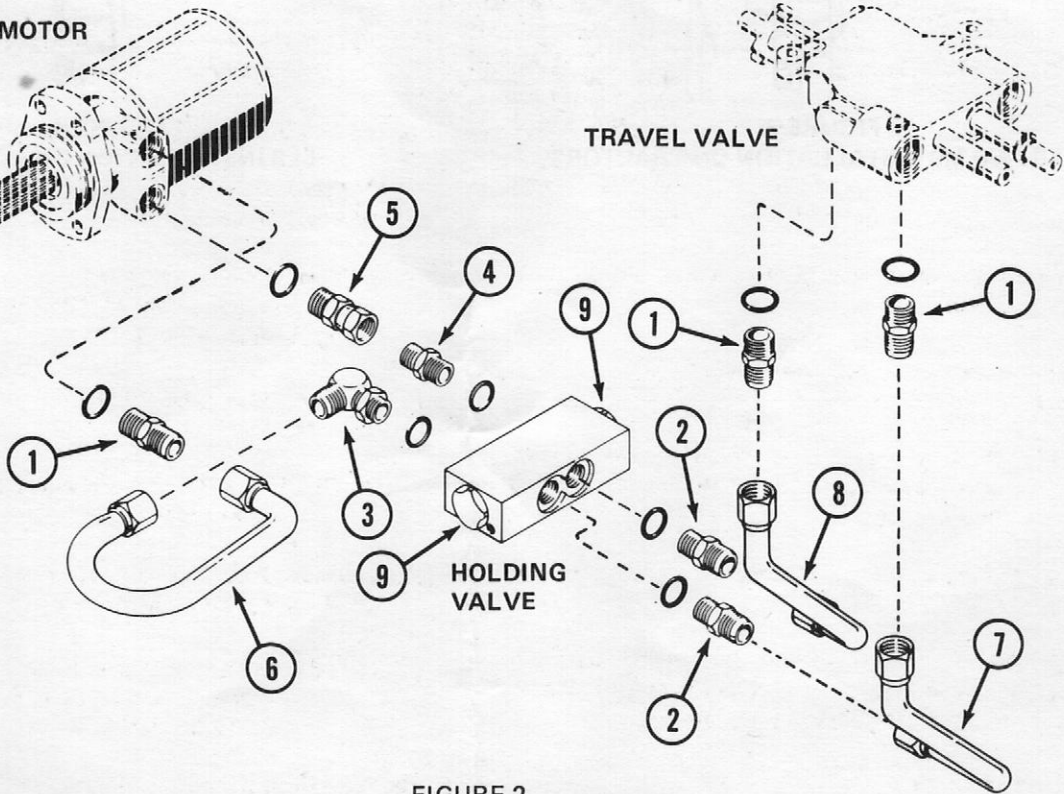

FIGURE 2
LL9 INSTALLATION ON LOADERS

HOLDING VALVE BLEEDING PROCEDURE

1. Place drain pan under holding valve.
2. Loosen two hex plugs (9) on holding valve about 2 turns or until o-ring is clear of the counter bore in holding valve body.
3. Place two speed transaxle in neutral.
4. Start engine, run at low idle.
5. Cycle travel control lever from Forward to Reverse (for loaders - place travel lever in Forward and Reverse and depress travel pedal) until all air is purged from space behind hex plugs and oil seeps from loosened plugs.
6. Tighten hex plug. Be careful not to pinch o-ring. Re-check oil level.

Test operate unit before placing into service.

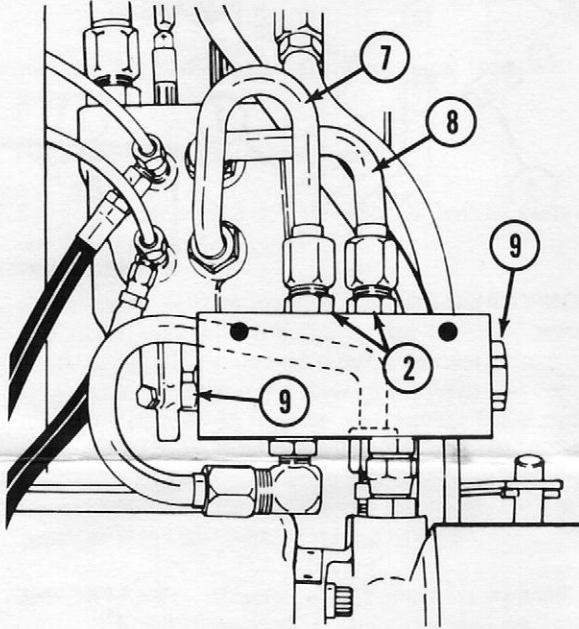

FIGURE 3
L7, L9 AND M9 INSTALLATION ON TRACTORS

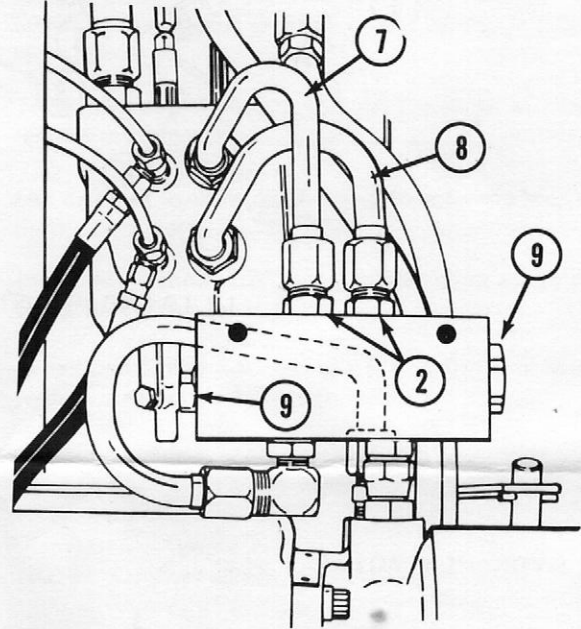

FIGURE 4
LL9 INSTALLATION ON LOADERS

Printed in U.S.A.