



H-26 3-Point Hitch
LT-26 3-Point Hitch
F-27 Sleeve Adaptor
Operator's Manual 9-99714

casecoltingersoll.com

JI Case
A Tenneco Company





This Safety Alert Symbol Indicates Important Safety Messages In This Manual When You See This Symbol Carefully Read The Message That Follows and Be Alert To The Possibility Of Personal Injury Or Death

IF THIS MACHINE IS USED BY AN EMPLOYEE OR IS LOANED OR RENTED, MAKE ABSOLUTELY CERTAIN THAT THE OPERATOR(S), PRIOR TO OPERATING:

- 1. IS INSTRUCTED IN SAFE AND PROPER USE.**
- 2. REVIEWS AND UNDERSTANDS THE MANUAL(S) PERTAINING TO THE MACHINE**

751253



WARNING

BEFORE STARTING ENGINE

**STUDY OPERATOR'S MANUAL SAFETY MESSAGES
READ ALL SAFETY SIGNS ON MACHINE
CLEAR THE AREA OF OTHER PERSONS**

**LEARN & PRACTICE SAFE USE OF
CONTROLS BEFORE OPERATING**

IT IS YOUR RESPONSIBILITY TO UNDERSTAND AND FOLLOW MANUFACTURER'S INSTRUCTIONS ON MACHINE OPERATION, SERVICE, AND TO OBSERVE PERTINENT LAWS AND REGULATIONS. OPERATOR AND SERVICE MANUALS MAY BE OBTAINED FROM YOUR EQUIPMENT DEALER.

SAFETY MESSAGES



The safety messages contained in this manual are to be used together with the safety messages appearing in the tractor operator's manual. Be sure to review both carefully before operating the tractor - attachment combination.



CAUTION: Be sure to apply sufficient front counterweight to tractor before operating with rear mounted attachment. Driving tractor with insufficient front counterweight could result in front end tip-up and personal injury.

Apply at least 110 lbs. (50 kg) for 200 series tractors and 140 lbs. (64 kg) for 400 series tractors.

Heavy attachments and attachments that extend far behind tractor may require more counterweighting. Operate tractor with extreme care and at slow speed to determine if more than the minimum amount of counterweight listed above is required. Add counterweight as necessary to achieve front end stability.

**DO NOT EXCEED
HITCH LIFT CAPACITY.**



Remember, a careful operator is always the best insurance against an accident. Always give complete and undivided attention to the job at hand.



CAUTION: Only operate controls while seated in the operator's seat.



CAUTION: Always lower any rear or front mounted implement to the ground when leaving the tractor unattended.



CAUTION: Place the transmission in neutral, set the parking brake and stop the engine before standing between the tractor and attachment when hitching.



CAUTION: Hydraulic systems are highly pressurized. Escaping hydraulic oil, even an invisible pinhole leak, can penetrate body tissues causing serious injury. Use a piece of wood or cardboard when looking for leaks - never use the hands or other parts of the body.

Relieve hydraulic pressure before disconnecting circuits. When re-assembling, make absolutely certain that all connections are tight.

If injured by hydraulic oil escaping under pressure, see a doctor immediately. Serious complications may arise if medical attention is not given at once.

IMPORTANT: Always install new decals whenever the old decals are destroyed, lost, painted over or illegible. When individual parts are replaced that have decals attached, be sure to install a new decal with the new part. Decals are available from your J I Case dealer.

INTRODUCTION

This manual contains recommended operating procedures, safety messages, assembly and mounting instructions. Read this manual carefully before operating your hydraulic 3-Point hitch and sleeve adaptor. The 3-Point hitch is designed in accordance with ASAE Specification, Category "O" and will accommodate all attachments manu-

factured to this standard.

The definitions "Right, Left, Front and Rear" as used throughout this manual relate to the tractor and hitch as the operator is seated facing forward in the normal operating position on the tractor.

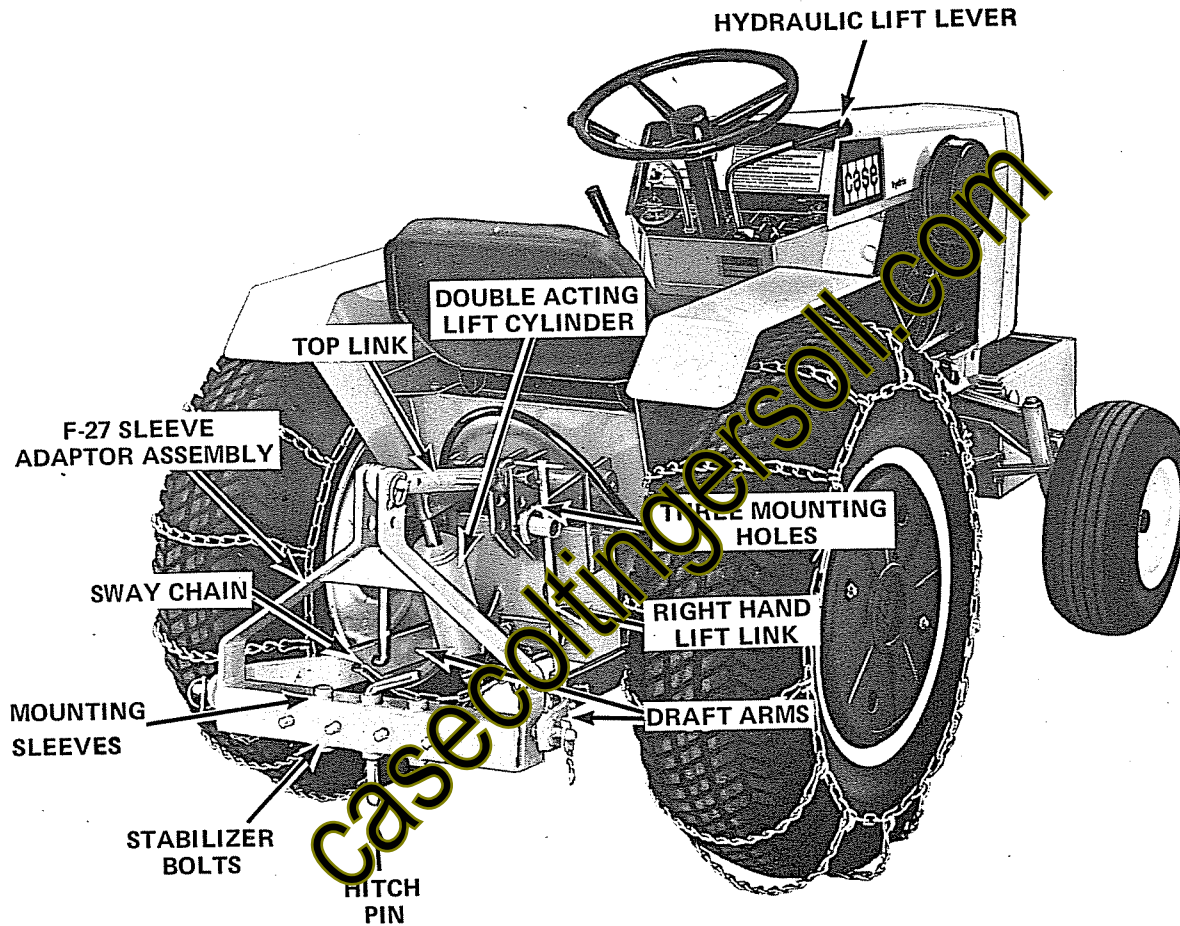

FIGURE 1

Model 444 Tractor shown with H-26 3-Point Hitch, F-27 Sleeve Adaptor, E-16 Tire Chains, K-10 Wheel Weights and H-13 Weight Box

HITCH APPLICATION CHART

HITCH MODEL	TRACTOR MODEL
H26	444 and 446 S/N 9646800 & above
LT26	644 and 646 All
F27	All H26 and LT26 Applications

OPERATING CONTROLS AND ADJUSTMENTS

1. Hydraulic Lift

The 3-Point hitch is connected to the tractor hydraulic lift circuit and is equipped with a double-acting hydraulic cylinder.

RAISE - Pull the hydraulic lift lever rearward to raise the hitch.

LOWER - Push the hydraulic lift lever partway forward to lower the hitch. Down pressure is applied when the hitch is in its lowest position (cylinder fully retracted).

The hydraulic lift centering spring returns the valve to neutral after raising or lowering the hitch.

FLOAT - Push the hydraulic lift lever fully forward for the float position. The lever will be held in float by a detent and must be manually returned to neutral.

The float position allows the attachment to follow the ground and is recommended for tilling or plowing.

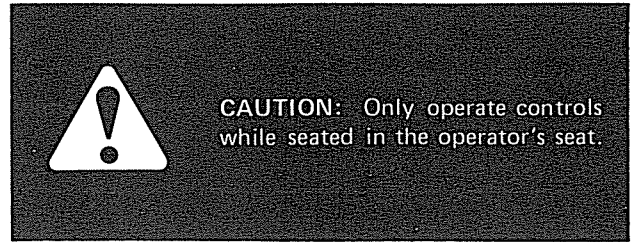

2. Right hand lift link. The right hand lift link is threaded and adjustable. Use it to level a mounted attachment or to compensate for the right wheels being in the furrow when plowing.
3. Top link. The top link is threaded and is used to set the fore-aft pitch of the attachment. Three mounting holes for the top link are provided on the hitch frame to aid in setting the fore-aft pitch adjustment.
4. Sway chain. The sway chain must be kept anchored to the draft arms and tow bracket to prevent interference with rear wheels.

F-27 SLEEVE ADAPTOR

The Model F27 sleeve adaptor converts the 3-Point Hitch to accept sleeve type mounted implements.

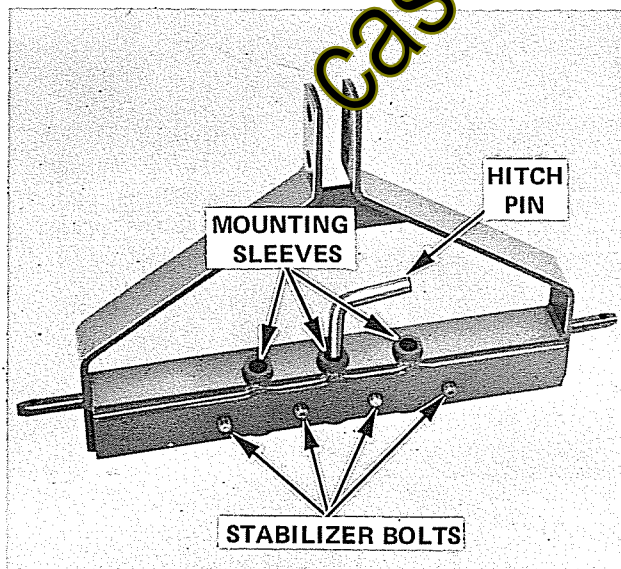
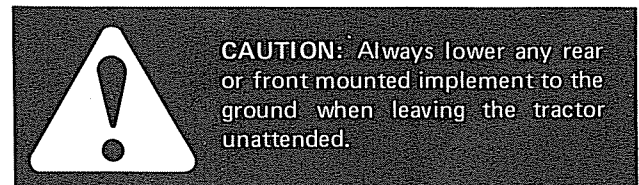

FIGURE 2
Model F-27 Sleeve Adaptor

1. Four implement stabilizing bolts (Figure 2) are furnished with the sleeve adaptor for use at the four threaded holes, to eliminate the lateral pivot of mounted attachments if desired. A plow should not be stabilized at this point.
2. There are three mounting sleeves (Figure 2) on the sleeve adaptor to permit centering or offsetting implements. When mounting a plow, be careful to select the mounting position which will allow the share to cut cleanly to the edge of the previous furrow and to the inside of the right rear wheel.

TIRE CHAINS, WHEEL WEIGHTS AND FRONT END WEIGHTS

The use of tire chains and wheel weights is recommended with the hitch. The extra traction resulting gives the tractor operator increased maneuverability. Front end weights or front weight box is required for stability.

NOTE: Front end weight may be added to loader bucket on models 644 and 646 if required.

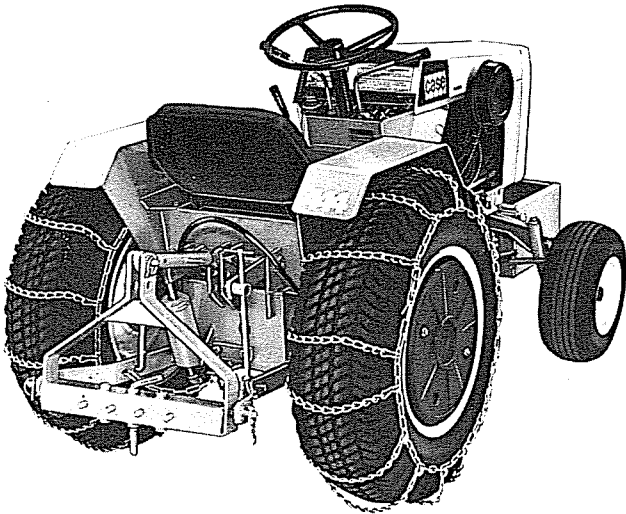

FIGURE 3



CAUTION: Be sure to apply sufficient front counterweight to tractor before operating with rear mounted attachment. Driving tractor with insufficient front counterweight could result in front end tip-up and personal injury.

Apply at least 110 lbs. (50 kg) for 200 series tractors and 140 lbs. (64 kg) for 400 series tractors.

Heavy attachments and attachments that extend far behind tractor may require more counterweighting. Operate tractor with extreme care and at slow speed to determine if more than the minimum amount of counterweight listed above is required. Add counterweight as necessary to achieve front end stability.

**DO NOT EXCEED
HITCH LIFT CAPACITY.**

MAINTENANCE

1. Grease two fittings on hitch rockshaft daily.
2. Apply oil to pivot pins and attachment mounting pins daily.
3. Do not oil ball joints as this may cause abrasive foreign material to lodge between the ball and retainer.
4. Check for tightness. After first two hours of operation, tighten the four bolts which secure hitch to tractor transmission.
5. A certain amount of oil will normally accumulate at the rod end as well as the base cap of the lift cylinder during operation which provides lubrication for the moving parts. There is no requirement for service or repair unless leakage is excessive.
6. Maintain tractor as described in Tractor Operator's Manual.

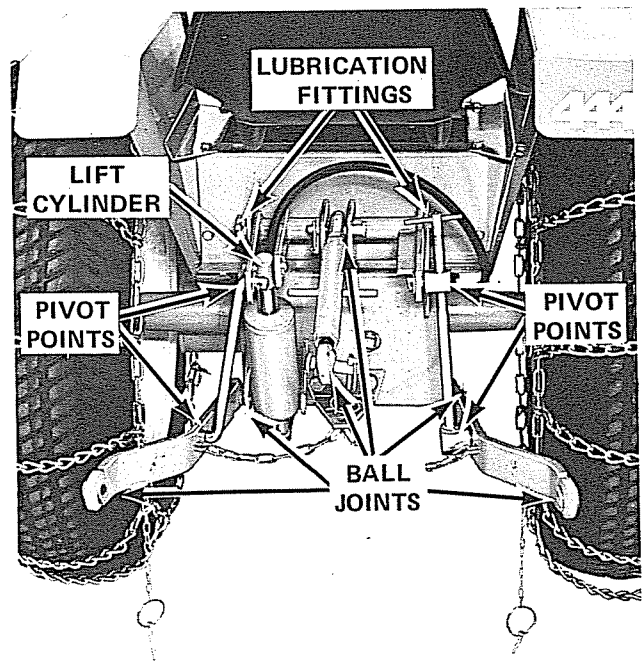

FIGURE 4
Lubrication Points

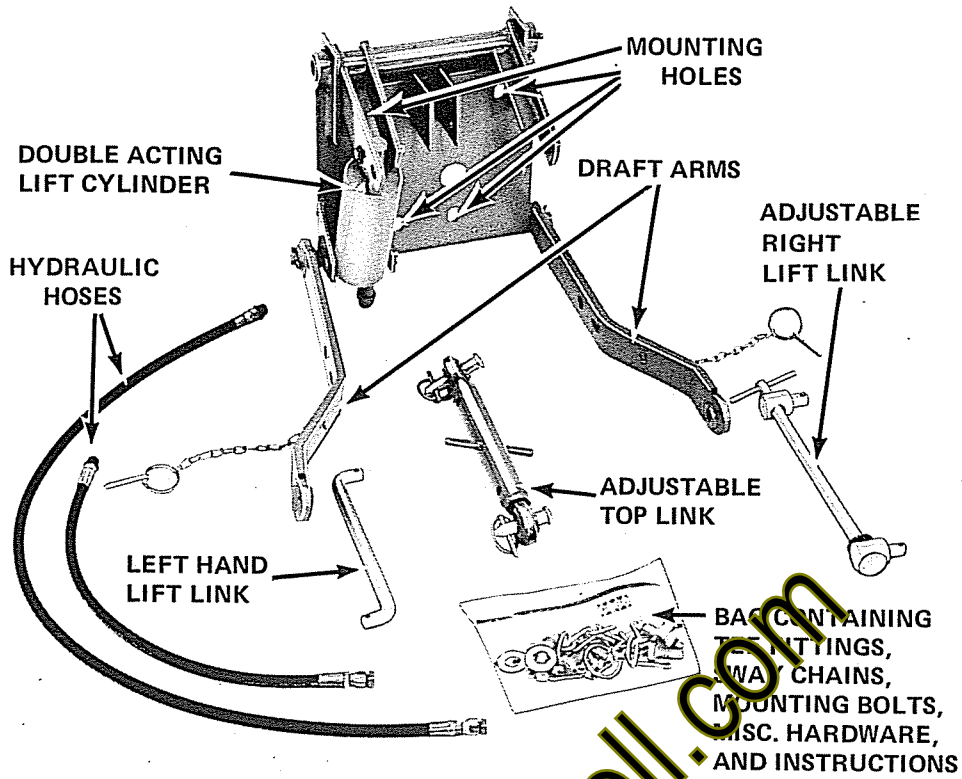

FIGURE 5
LT-26 3-Point Hitch - Disassembled

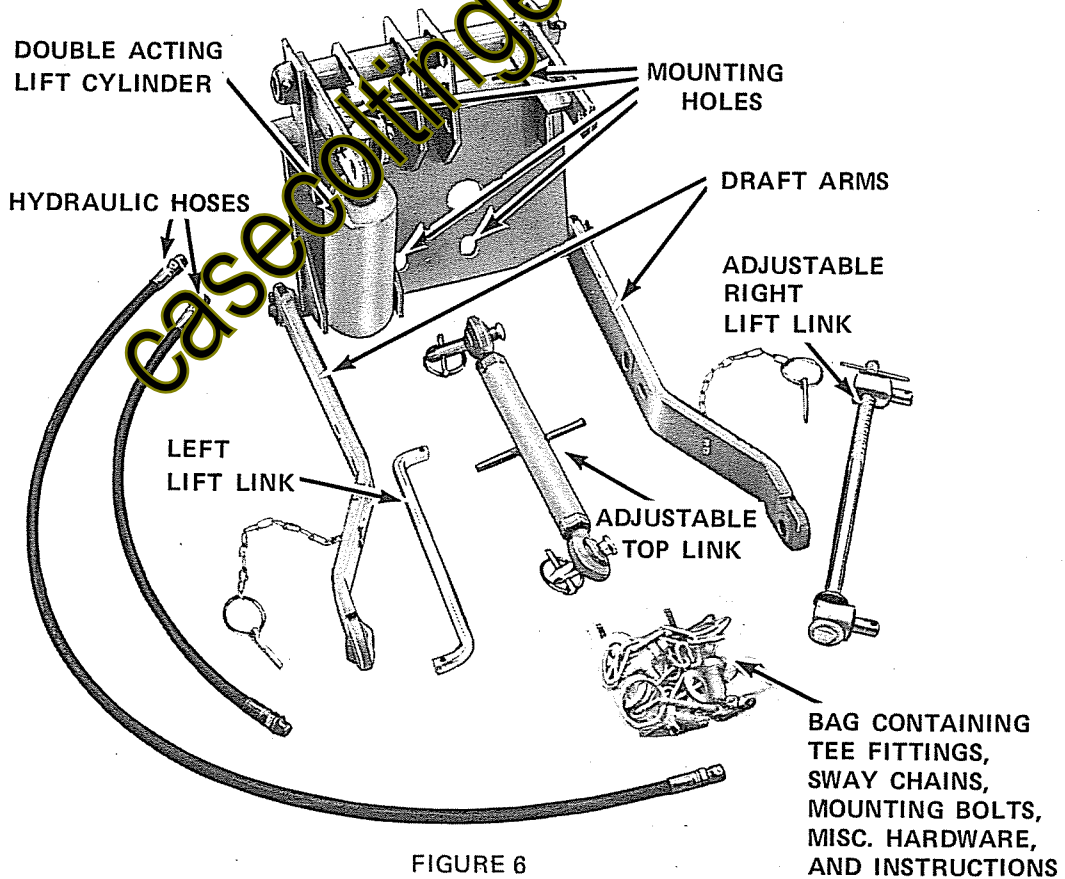

FIGURE 6
H-26 3-Point Hitch - Disassembled

INSTALLATION

1. Identify and inspect 3-Point hitch assembly for completeness before beginning installation. Refer to Figures 5 or 6. Keep hydraulic hose end capped to prevent dirty entry.
2. Locate tractor on a clean, level surface such as a concrete garage floor.

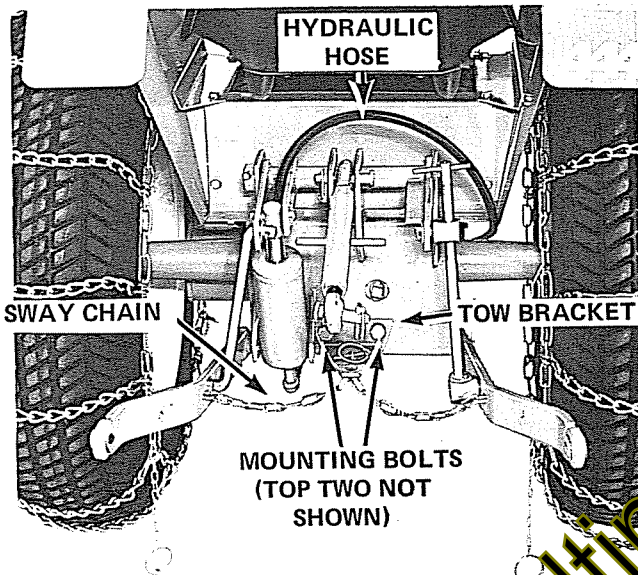

FIGURE 7
H-26 3-Point Hitch

3. Remove tow bracket from rear of tractor.
4. For H-26 hitch only. Remove two (2) rear seat support mounting bolts and lockwashers.
5. A For H-26 hitch only. Position the 3-Point hitch assembly on the seat support and secure with the same bolts and lockwashers removed in Step 4.
B For LT-26 hitch only. Position hitch assembly against rear of loader. Install two bolts and lockwashers provided in upper mounting holes.
6. Install the tow bracket using the same bolts and lockwashers removed in Step 3.

NOTE: It may be necessary to file or grind the left side of the tow bracket to provide clearance for the cylinder mounting lug.

7. Insert the center link of the sway chain in the tow bracket slot and secure with the klik pin provided. Install end links through slots in draft arms and secure with small bolts and self-locking nuts provided.
8. Install threaded lift link (adjustable) to right draft arm and rockshaft as illustrated. Secure with flat washers and cotter pins provided.
9. Install solid lift link (non-adjustable) to left draft arm and rockshaft as illustrated. Secure with flat washers and cotter pins provided.
10. Place the travel and hydraulic lift lever in the neutral position.
11. Place a clear bar under tractor travel and lift valve.

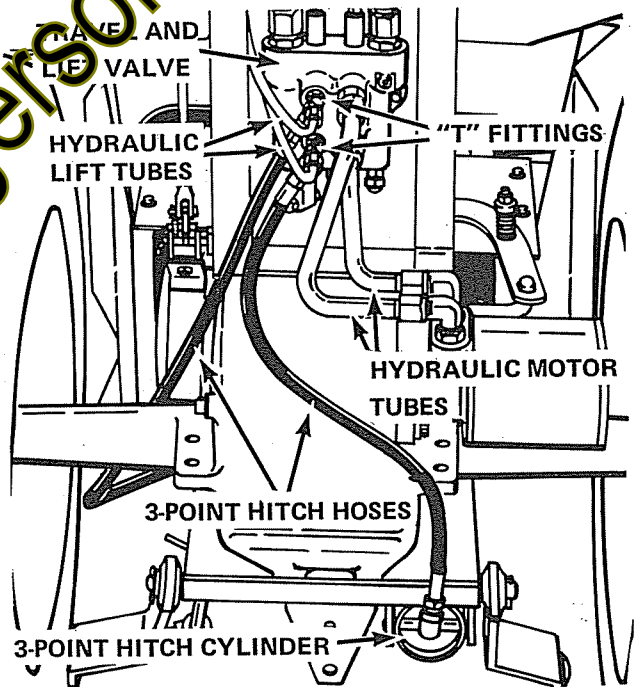

FIGURE 8

NOTE: For LT-26 3-Point hitch only. Late production 644 and 646 loaders have tee fittings factory installed. Steps 12, 13, 14 and 19 can be omitted if tee fittings are installed.

Remove caps and install hoses as described in steps 15 through 18 from tee fitting.



CAUTION: Hydraulic systems are highly pressurized. Escaping hydraulic oil, even an invisible pinhole leak, can penetrate body tissues causing serious injury. Use a piece of wood or cardboard when looking for leaks - never use the hands or other parts of the body.

Relieve hydraulic pressure before disconnecting circuits. When re-assembling, make absolutely certain that all connections are tight.

If injured by hydraulic oil escaping under pressure, see a doctor immediately. Serious complications may arise if medical attention is not given at once.

12. Disconnect the hydraulic lift tubes from the travel and lift valve and remove the fittings from the lift ports.
13. Remove the tubes between the valve and hydraulic motor. In some cases it might also be necessary to remove the fittings from the valve for clearance to install the "T" fittings.
14. Turn the "T" fittings into the lift ports of the valve. With the fittings facing toward the right rear corner of tractor as shown in Figure 8 tighten the swivels against the valve housing.
15. Install the short hose in the elbow fitting in piston end of 3-Point hitch cylinder. Tighten fitting.
16. Route hose under transmission and install to rear "T" fitting in travel and lift valve.
17. Install the long hose in the rod end of 3-Point hitch cylinder.
18. Route hose over top of hitch, over right axle and install to front "T" fitting in travel and lift valve.
19. Install the hydraulic motor tubes.
20. Check and tighten all connections as required.
21. Start the tractor and operate the cylinder to full open and closed positions several times to expel all air from the system. Shut off the tractor and check for oil leaks at all connections. Check the oil level in the reservoir and add if necessary to bring to proper level as described in tractor operator's manual.
22. Tire pressure should be checked and adjusted, if necessary, in accordance with the tractor operator's manual.

NOTE: The J I Case Company reserves the right to make improvements in design or changes in specifications at any time without incurring any obligation to install them on units previously sold.

casecoltingersoll.com

Printed In U.S.A.