

Scanned copy provided
by Al Leischer
May 5, 2014

operator's manual
and
maintenance
instructions

HUSKY TRACTOR

1250
HYDROSTATIC

MODEL 197-01



BOLENS

PORT WASHINGTON, WISCONSIN, U.S.A.

SAFE OPERATING PRACTICES

Serious accidents can be prevented. Every operator should approach the following safety practices with serious intentions of conforming to them. An accident prevention program can be successful only with wholehearted co-operation.

1. Always place transmission lever in PARK prior to starting tractor.
2. Always place transmission lever in PARK whenever vehicle is to be left unattended. Ground all attachments.
3. Attachments must be GROUNDED when storing tractor.
4. Do not tow vehicle over eight miles per hour.
5. When towing or moving the vehicle, place transmission lever in NEUTRAL.
6. Keep hands clear of transmission cooling fan.
7. Do not mount or leave vehicle while it is in motion or in actual operation, nor leave vehicle unattended while engine is running.
8. Do not carry passengers.
9. Do not start or operate vehicle in an enclosed area unless steps have been taken for sufficient ventilation.
10. Keep tractor and attachments free of excess grease and oil.
11. Engine must be stopped, and P.T.O. disengaged when cleaning, servicing, adjusting, repairing, or installing attachments on tractor.
12. Always disconnect ground (-) battery cable from battery before doing any work on the electrical system.
13. Study your manual. Know your tractor before operating it. Take time to operate the unit in the safest manner.
14. Always follow manufacturer's operational suggestions.
15. Do not allow minors to operate vehicle without proper instruction and adult supervision.
16. Do not allow adults to operate vehicle without proper instruction.
17. Do not fill gasoline tank when engine is running or hot.
18. When adding weight to rear wheels to improve traction, do not use more than 3 wheel weights per wheel. Wheel weights are 40 lbs. each, 120 lbs. total for each wheel.

INTRODUCTION

In 1919, Bolens engineered, manufactured, and introduced the first garden tractor . . . your new HUSKY tractor represents years of research, engineering, and manufacturing skills. For this reason, we have dedicated this manual to assist you in obtaining trouble free performance and to know the advantages and features of your HUSKY tractor.

Your Bolens dealer has been carefully chosen to service your equipment for top performance through all the years you use it. Take your HUSKY to him at regular intervals for inspection and servicing. Feel free to contact him for answers to questions which you can not find in this manual.

TABLE OF CONTENTS

	Page		Page
Safe Operating Practices	Inside Front Cover	Adjustments	9
Serial Number	2	Maintenance Guide	10
Specifications	2	Lubrication	10
Break-In Period	3	Lubrication Chart	10
Controls	3	Power Take-Off (P.T.O.)	12
Pre-Operational Checks	4	Minor Trouble Shooting Guide	13
Starting the Engine	4	Wiring Diagram	13
Run-In Period	5	Optional Equipment	14
Operation	5	Storing Your Husky Tractor	15
Stopping the Engine	7	Warranty	Back Cover
Preventative Maintenance	7		

TO THE OWNER

This is an operational and general maintenance manual only and does not cover major repair. All major repair work must be performed by an authorized BOLENS DEALER or the factory warranty is void. Bolens equipment is carefully engineered to give trouble-free performance if properly operated and maintained. Keep your equipment clean and lubricate it as prescribed in this manual. Periodically inspect your unit and perform any upkeep maintenance necessary.

Your dealer is obligated by the factory to completely assemble and service new equipment prior to delivery, and thoroughly explain and demonstrate its operation. He will repair or replace any parts which fail due to defective material and/or workmanship during the warranty period, and also provide future repair service and supply genuine factory repair parts.

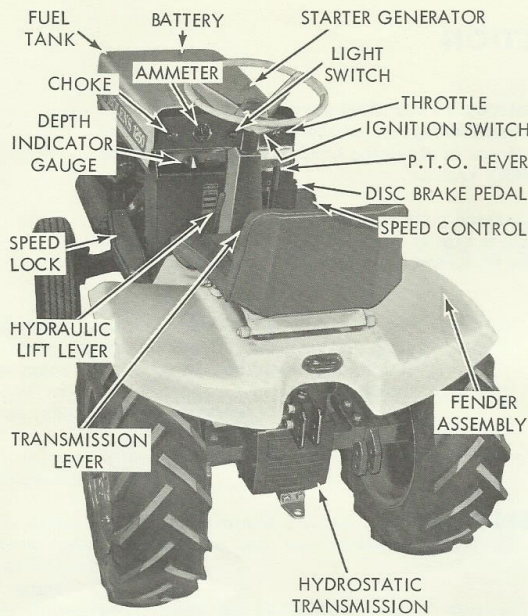

Figure 1

SERIAL NUMBER

To ensure prompt service when repairs or adjustments are required, your Bolens Dealer must have the following information:

1. Model number of unit.
2. Serial number of unit.
3. Model number of engine.
4. Serial and Spec. number of engine.

Your Bolens dealer has available a master Parts List for your unit. He can identify any parts you may require and furnish genuine factory replacements.

When ordering engine component parts, consult the Engine Manufacturer's Manual.

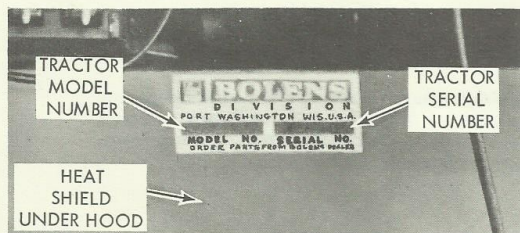

Figure 2

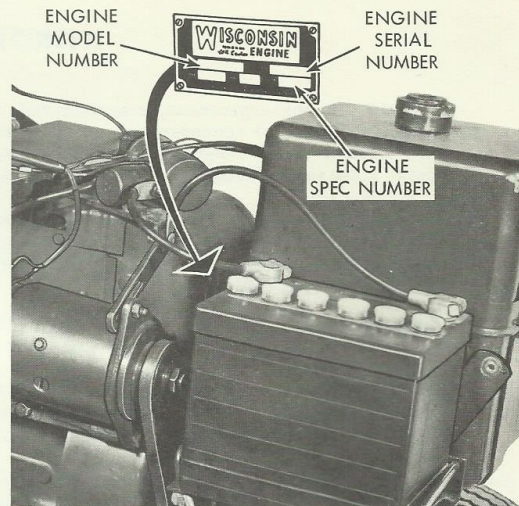

Figure 3

For your own personal reference, fill in the spaces provided below.

Model Number of Unit _____
 Serial Number of Unit _____
 Engine Model Number _____
 Engine Serial Number _____
 Engine Spec. Number _____

SPECIFICATIONS

(Specifications subject to change without notice)

NOTE

Bolens reserves the right to make changes or improvements to its products without obligation to install same on products previously manufactured.

Engine 28.86 cu. inch Wisconsin
 Type 4 cycle, single cylinder, air cooled
 Fuel capacity 5.3 gallons
 Engine oil capacity 2 quarts
 Transmission oil capacity 10 quarts
 Air cleaner Dry type
 Drive Hydrostatic transmission
 Speed . Infinitely variable. Forward: approx. 0-8 mph
 Reverse: approx. 0-4 mph
 Power to attachments . . Triple belt drive (P.T.O.),
 with universal joints and
 splined shaft.

Tires . . . Front: 5.70/5.00-8
 Rear: See optional equipment section,
 page 14.

Height 45 inches
 Width 38 inches
 Length 72 inches
 Wheelbase 49 inches
 Turning radius 54 inches
 Ground clearance 8-1/2 inches
 Shipping weight 975 lbs.

Standard equipment . . . P.T.O., splined shaft to drive front, center or rear attachments, hydraulic lift system with visual depth gauging, electric starting, head lights and tail lights, full fenders, adjustable all-angle seat-spring suspension with foam-padded adjustable seat (easily removable for weather protection), 45 amp battery, selector level for drive-neutral-park, tapered roller bearing front wheels and replaceable spindle bushings, automotive type muffler, compression release for easy starting, coil ignition, three-unit regulator (automotive type), ammeter, extra-heavy channel frame, tilting hood for access to engine.

Location of tractor model and serial number Top left side of heat shield
 Location of engine model and serial number Front of engine cowling

BREAK-IN PERIOD

As with a new car, your new HUSKY Tractor should receive special attention. During the first few hours of operation, it is best to vary the engine speed (see inside front cover of engine manual) avoid full-throttle driving . . . and avoid quick starts and stops until you have become well acquainted with your tractor. **IMPORTANT: THE TRACTOR IS SHIPPED FROM THE FACTORY WITH OIL IN THE ENGINE CRANKCASE. CHECK THE CRANKCASE AND THE HYDROSTATIC TRANSMISSION OIL RESERVOIR FOR PROPER OIL LEVEL BEFORE ATTEMPTING TO START YOUR UNIT. BECOME FAMILIAR WITH THE LOCATION OF EACH CONTROL. BE SURE TRANSMISSION LEVER IS IN "PARK" POSITION.**

Both the tractor and engine have been fully tested by the factory and your dealer to assure your complete satisfaction. Keep this manual available at all times, read it carefully, if you have any questions that are not answered in the manual, consult your Bolens dealer.

CONTROLS

Before operating the tractor, the operator should become familiar with the function and location of each control to ensure proper and efficient operation.

The following listed numbers and accompanying information correspond to those numbers assigned to the controls indicated in Figure 4.

1. Choke. Pull choke knob out to operate choke.
2. Ammeter. Indicates level of charge or discharge to or from battery.
3. Light Switch. Pull light switch knob out to turn on lights push in to turn lights off.

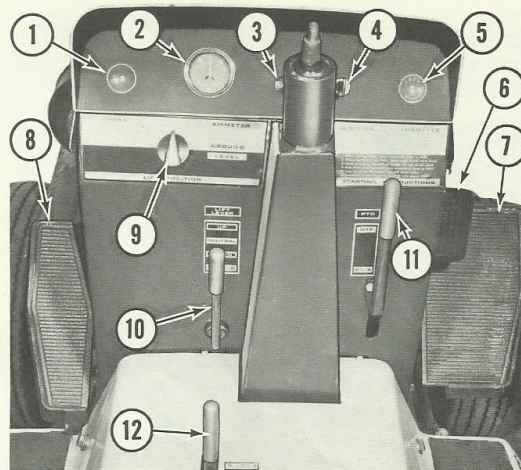

Figure 4

NOTE

Ignition-starter switch (4) must be ON to turn on head and tail lights.

4. Ignition-Starter switch. Turn ignition switch against spring tension to actuate starter. Release when engine starts.

5. Throttle. Pull throttle knob out one-half way for starting. More or less throttle may be required due to grade of fuel and temperature variations. Allow engine to warm up, then adjust throttle to full engine R.P.M. while operating under load.

6. Foot Brake. Use when vehicle is being towed or free-wheeling; when moving transmission lever (12) from NEUTRAL or PARK position to DRIVE position.

7. Speed Control. Depress with toe of foot for forward motion. Depress with heel of foot for reverse motion. Provides instant braking and speed regulation. (See Figure 7.)

8. Speed Hold. Can be used to hold speed control (7) at a desired speed setting. Depress with toe of left foot to hold, and depress with heel of left foot to unlock. See Figure 6 for operation of speed hold on page 5.

9. Depth Indicator Gauge. Allows operator to locate original height or depth of attached implement.

10. Hydraulic Lift Lever. Push lever forward to raise and pull lever back to lower attachments. Pull lift lever all the way back for FLOAT position.

11. Power Take-Off (P.T.O.) Lever. Engages and disengages power to attached implements. Lever positions indicated on etched plate.

12. Transmission Lever. Place transmission lever in
- NEUTRAL for towing.
 - DRIVE for infinitely variable speeds from 0-8 mph forward to 0-4 mph in reverse.
 - PARK for starting and when tractor is At-Rest.

CAUTION

Do not place transmission lever into PARK position while tractor is in motion. Premature shifting into PARK may result in serious damage to the hydrostatic transmission.

PRE-OPERATIONAL CHECKS

The operator should become familiar with the following pre-operational check list prior to starting or operating the HUSKY.

1. Thoroughly clean area around crankcase oil dipstick, and check for proper level of engine oil. See Engine Manufacturer's Manual.
2. Thoroughly clean area around hydrostatic transmission fill plug area, and check for proper level of transmission fluid. See Lubrication Chart.
3. Check battery for proper water level.
4. Check gasoline tank for sufficient gas supply.
5. Check that air cleaner screen is free of debris. Check and clean regularly. Replace if necessary.
6. Clean flywheel screen. Check and clean regularly.
7. Visually check for loose nuts and screws.
8. Check for 6-8 lbs. tire inflation. **TIRE INFLATION SHOULD NOT BE LESS THAN 6 LBS.**
9. Do not allow ignition switch to remain in the on position when engine is not running.

STARTING THE ENGINE

ELECTRIC STARTING

1. Be sure power take-off (P.T.O.) safety clutch is in the OFF position, and the transmission lever is in PARK position.
2. Pull out choke. Experience will indicate need for more or less choking due to temperature variations, grade of fuel, engine heat, etc.
3. Pull out throttle one-half way. More or less throttle may be required due to grade of fuel and temperature variations.
4. Turn ignition key against spring tension to actuate starter. Release key when engine starts.

5. Allow engine to warm up. Move choke slowly forward; pull out throttle and lock at full speed while operating.

6. To stop the engine, bring engine back to idle, place transmission lever in PARK and turn ignition switch off. Remove the ignition key when the tractor is not in use, or left unattended.

EMERGENCY STARTING

In case of an electrical failure, proceed as follows:

1. Recharge or replace battery.
2. Jumper cables may be used. **NOTE:** If jumper cables are used, cables must be connected, Positive (+) to Positive (+) and Negative (-) to Negative (-).
3. After engine has started, allow it to warm up. Move choke knob slowly forward, pull out throttle and lock at full speed.
4. Remove battery and have it fully charged as soon as possible.
5. After the battery is fully charged, reinstall it in the tractor, being careful to connect ground cable last.

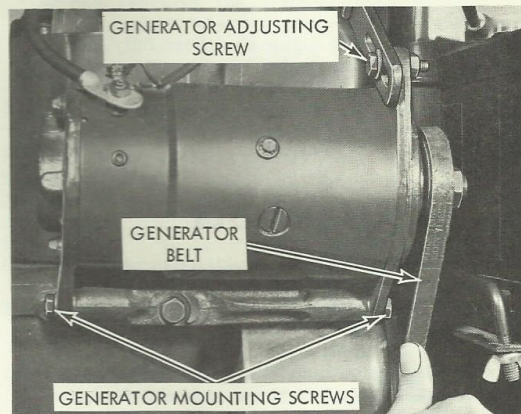

Figure 5

6. Check generator belt for proper tension. Belt should depress 1/4 inch between pulleys as shown in

Figure 5. Should adjustment be required, loosen generator mounting screws and generator adjusting screw. Pivot generator outward from engine until proper tension is obtained.

NOTE

Never pry out generator with a long heavy bar or tool as this could result in premature bearing failure.

7. Tighten the generator mounting screws and generator adjusting screw. Make sure all bolts are torqued securely.

RUN-IN PERIOD

Before operating the tractor at full load, it should be operated at one-half throttle for approximately one-half hour with no load applied. After the first half-hour of operation, run the tractor at full throttle with no load applied for an additional one-half hour.

Attach a light load to the tractor. Operate the tractor with light load for a period of three hours at full throttle. The tractor is now ready for normal load operation.

NOTE

Always operate the engine at full throttle for best attachment performance.

OPERATION

Before driving the HUSKY, the operator should be familiar with the location and functions of all controls.

Place transmission lever in PARK position. Start the tractor and allow it to warm up.

Placing the transmission lever in PARK position locks the speed control pedal in its centered or neutral position, to prevent use of speed control pedal when selector lever is in PARK.



Figure 6

Release constant speed hold pedal with heel of left foot before again attempting to change speed with the speed control pedal, or stopping tractor. (See Figures 6 and 7.)

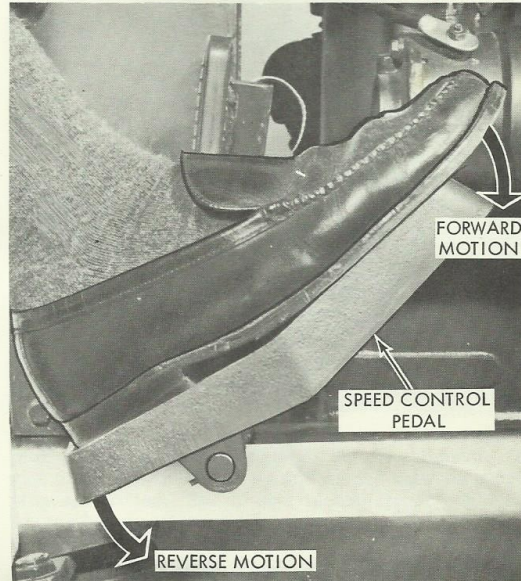

Figure 7

CAUTION

Do not use constant speed hold pedal for a foot rest at any time.

Depress foot brake (Figure 4, Reference 6) and place transmission lever in DRIVE position. ALWAYS DEPRESS FOOT BRAKE PEDAL BEFORE MOVING TRANSMISSION LEVER INTO "NEUTRAL", "PARK" OR "DRIVE" POSITION TO AVOID CREEPING.

Release brake pedal, and slowly apply pressure to the speed control pedal with toe of right foot for forward motion, or if reverse motion is desired, slowly apply pressure to speed control pedal with heel of right foot. (See Figure 7.)

The hydraulic lift lever can be maneuvered while vehicle is at rest or in motion. Push lever to raise and pull back on lever to lower attachments. When the lever is released, it will automatically return to NEUTRAL position and hold, except when in the FLOAT position. Pull lift lever all the way back to lock in FLOAT position. The FLOAT position can be used when the operator wants the attached implement to follow ground contours. (See Figure 9.)

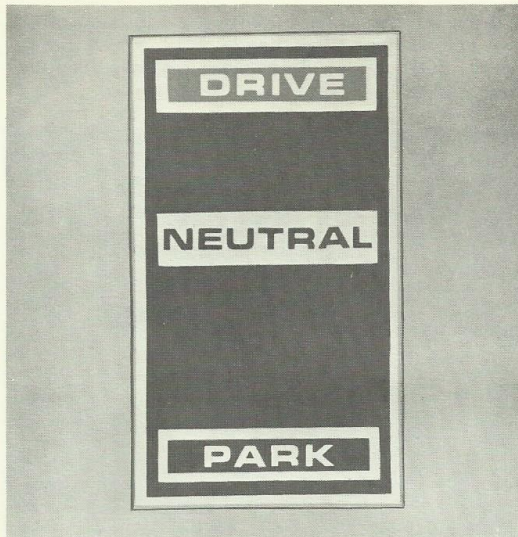

Figure 8

NOTE

The hydraulic lift lever, except when placed in FLOAT position, should always return to the NEUTRAL position after raising or lowering operations.

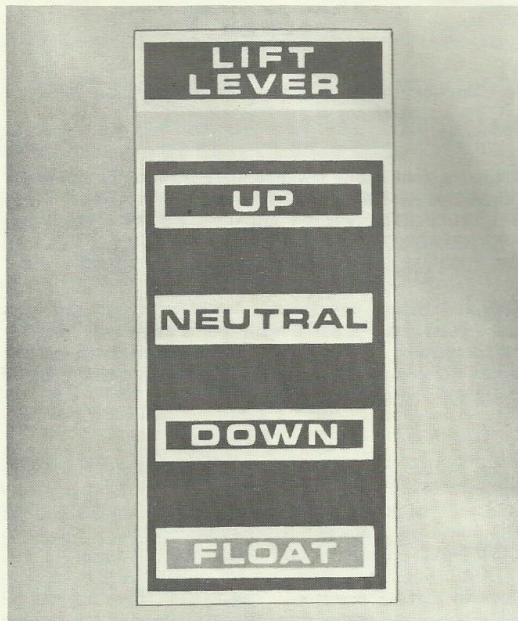

Figure 9

Located on the instrument panel is a depth indicator gauge which is used in conjunction with the lift lever. Lower the attached implement to its desired height or depth, and manually turn the indicator gauge to the ground level position indicated in Figure 10. By visually observing the depth indicator when lowering an attachment, the lift lever can be released when indicator reaches the original desired setting. **NOTE:** Study each attachment owner manual for additional information on DEPTH GAUGE INDICATOR.



Figure 10

The P.T.O. and hydrostatic transmission are separate systems, therefore, the P.T.O. can be engaged or disengaged as desired by the operator. **IMPORTANT: DO NOT ENGAGE P.T.O. WITHOUT AN IMPLEMENT ATTACHED. ALWAYS REMOVE JOINTS FROM P.T.O. SHAFT WHEN ATTACHMENT IS REMOVED.**

The hydrostatic transmission gives the operator a choice of infinitely variable speeds from 0 to 8 mph forward, and 0 to 4 mph in reverse. Avoid excessive HIGH speed whenever possible. High speeds are most practical for transport or pulling light attachments. Lower speeds are best for heavy jobs such as snow casting or mowing tall grass.

When using attachments, it is recommended that the tractor operate at full throttle. While operating under heavy load conditions, listen to the engine R.P.M. As the engine begins to strain, let up on the speed control accordingly, do not advance speed control. By letting up on the speed control pedal, the ground speed will decrease and the engine speed will increase, thereby, allowing engine to maintain constant P.T.O. speed. (See Figure 11.)

The speed control pedal is generally used for dynamic braking. To slow down or stop the tractor while it is in forward motion, gradually apply pressure to the speed control pedal with heel of right foot until tractor comes to a full stop. To slow down or stop the tractor while it is in reverse motion, apply pressure to speed control pedal with toe of right foot until tractor comes to a full stop.

The constant speed hold pedal may be used when riding tractor for long distances at constant speed. Advance the speed control pedal to desired speed, then lock speed lock pedal as shown in Figure 6. To stop the vehicle, **FIRST** disengage the speed lock with

heel of left foot, then gradually apply pressure to speed control pedal in the direction desired with right foot until tractor comes to a full stop.



Figure 11

CAUTION

Do not attempt to place transmission lever in PARK position until tractor has come to a full stop.

When towing the tractor, place the transmission lever in NEUTRAL position. DO NOT EXCEED SPEEDS OF 8 MPH WHILE TOWING. Use foot brake pedal to stop vehicle when towing.

STOPPING THE ENGINE

1. If the engine has been operating under a heavy load and is hot, do not stop it suddenly. Allow the engine to idle for approximately three to five minutes. This will reduce the engine temperature more quickly and evenly than stopping the engine.

2. Turn ignition switch off.

PREVENTATIVE MAINTENANCE

Operational maintenance and preventative maintenance are synonymous. When neglected, unnecessary down time and costly repairs can result. A little time spent each day by the operator on preventative maintenance will lead to longer operating life of the HUSKY.

The removal of debris, dirt and grease accumulations are considered normal maintenance practices and can help discover minor difficulties before they become troublesome.

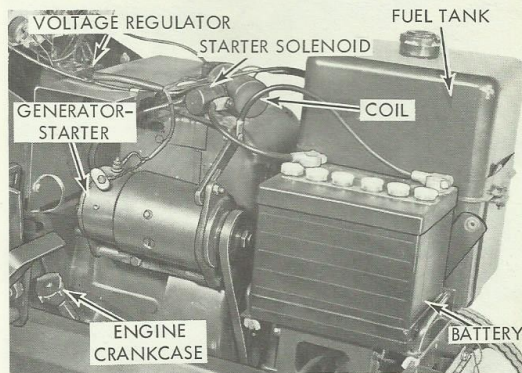

Figure 12

ENGINE - Remove all dirt from around base of spark plug and crankcase oil dipstick before removing. A gap of .030 inch should be maintained between spark plug electrodes. See Engine Manufacturer's Manual for further maintenance of engine.

HYDROSTATIC TRANSMISSION - Remove all dirt from around transmission filler plug area and filter before removing. Turn filter counterclockwise to remove. Clean transmission cooling fins periodically with an air hose. If tractor is being operated in a dusty environment, clean cooling fins frequently. Consult your Bolens dealer for transmission maintenance. (See Figures 13 and 14.)

FRONT WHEEL BEARINGS -

1. Remove hub cap.
2. Extract cotter pin and unscrew slotted nut.

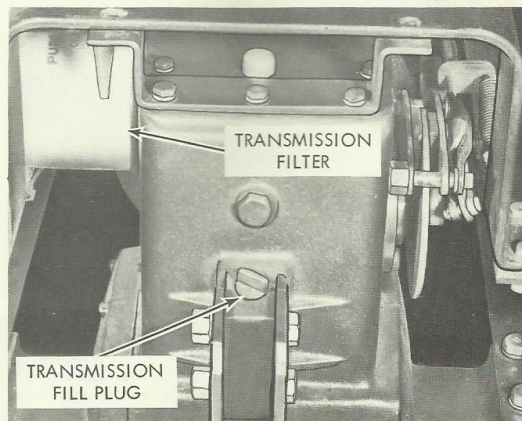

Figure 13

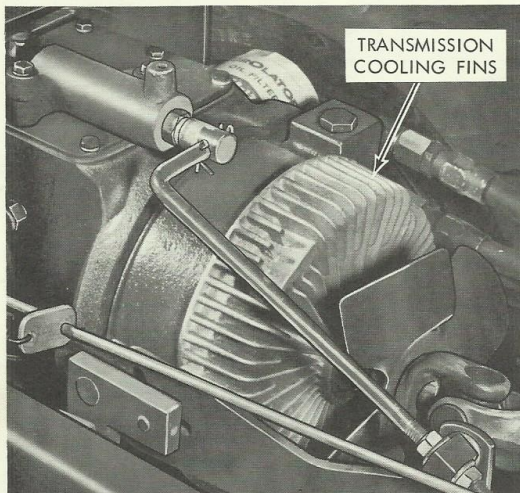

Figure 14

3. Remove bearing.
4. Pack bearings with the lubricant called out in the Lubrication Section of this manual.
5. Install bearing.
6. Turn slotted nut on spindle hand-tight, test-spin wheel to align bearings, then back nut off to nearest slot.
7. Insert new cotter pin and press on hub cap.

FUEL TANK - Fill with clean fresh gasoline of regular grade. (For cold weather operation use winter blend gasoline.) **DO NOT MIX OIL WITH GASOLINE.**

Check to see that vent hole in fuel tank cap is not plugged.

GENERATOR - Keep terminals tight and clean. Check belt for wear. Replace if badly worn.

AIR CLEANER - See Engine Manufacturer's Manual.

BATTERY - Keep cables and terminals clean and apply a light coat of vasoline or oil for protection. Check battery bracket for corrosion and keep clean. Do not over-tighten battery mounting. Reinstall in same position. **IMPORTANT:** When servicing the battery, be sure battery cables are disconnected before attempting removal of the battery from the tractor. **ALWAYS DISCONNECT GROUND CABLE FIRST.** When installing the battery, always check the polarity of the battery terminals to be sure the battery is not reversed. The negative terminal (-) is ground. Apply a light coat of vasoline or oil to the inside of the clamp terminals and over the bolt

stud before connecting terminals. **ALWAYS CONNECT THE GROUND TERMINAL LAST.**

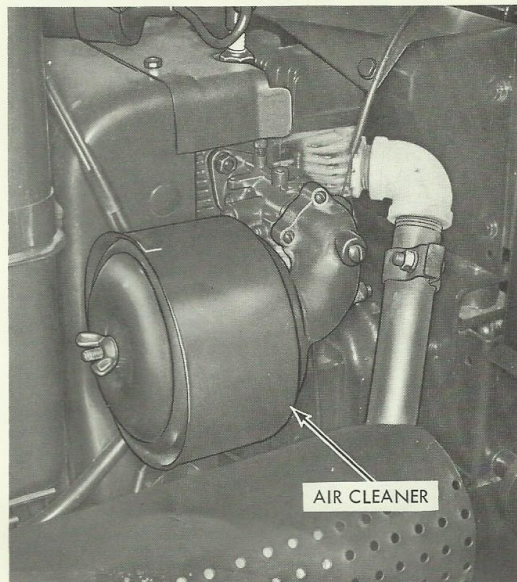

Figure 15

VOLTAGE REGULATOR - Keep terminal connections tight and clean. Consult your dealer for servicing adjustments or repairs.

STARTER SOLENOID - Keep terminal connections tight and clean.

PNEUMATIC TIRES - Keep both front and rear tires inflated (6 to 8 pounds recommended depending on vehicle load). Under no circumstances should tire inflation be less than 6 pounds. Check air pressure regularly with a low pressure gauge. Over or under inflation will result in premature tire failures.

ADJUSTMENTS

For adjustments not discussed in this manual, consult your Bolens dealer.

TOE-IN ADJUSTMENT (See Figure 16.)

1. Place steering wheel in its mid-position.
2. Loosen hex nut on tie rod, and turn tie rod until 0 to 1 degree toe-in is obtained.
3. Tighten hex nut securely.

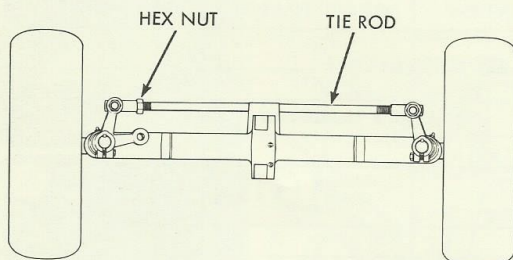

Figure 16

POWER TAKE-OFF (P.T.O.) LEVER (See Figure 17.)

1. Place P.T.O. lever in the OFF position.
2. Remove spring cotter pin and turn the P.T.O. control rod until the desired tension is obtained, or the "over-the-center" snap is felt when moving the P.T.O. lever from OFF position to ON position. Re-install spring cotter pin.

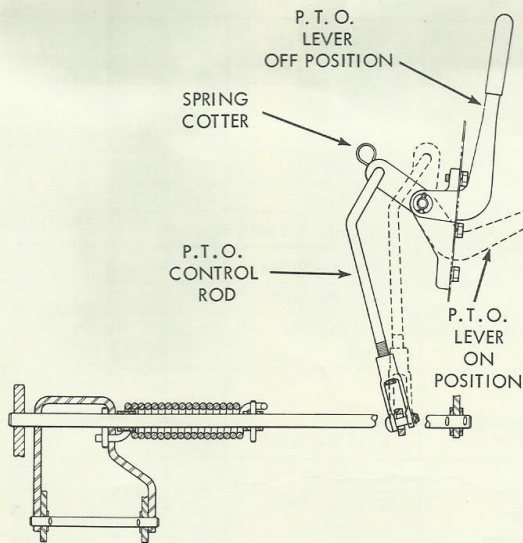

Figure 17

3. With the P.T.O. lever still in the ON position, loosen the hex capscrew which secures the upper belt guide shown in Figure 18. Adjust upper belt guide for a 1/8 inch clearance between belt and belt guide. Tighten hex capscrew securely.

P.T.O. BELT ADJUSTMENT (See Figure 18.)

Should it become necessary to replace P.T.O. belt, install new belt as follows:

1. Place P.T.O. lever in the ON position.
2. Loosen hex capscrew which secures upper belt guide, and adjust for a 1/8 inch clearance between belt guide and newly installed belts. Tighten hex capscrew securely.
3. Loosen the two hex capscrews which secure the lower belt guide, and adjust for a 3/32 to 1/8 inch clearance between belt guide and belts. Tighten the two hex capscrews securely. Place P.T.O. lever in OFF position.

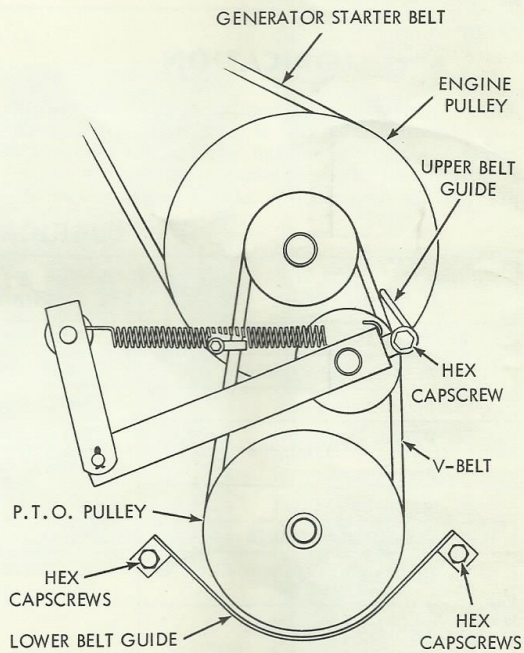

Figure 18

DISC BRAKE (See Figures 21 and 22.)

1. Remove cotter pin and clevis pin from brake rod assembly.
2. Hold brake pedal in its normal relaxed position. Turn end yoke until one inch of free brake pedal

MAINTENANCE GUIDE

	EVERY 10 HOURS OF OPERATION	EVERY 25 HOURS OF OPERATION	EVERY 50 HOURS OF OPERATION
Check battery	X *		
Check air in tires (6 to 8 lbs.)		X*	
Check engine crankcase oil	See Engine Manufacturer's Manual		
Drain engine crankcase oil			X *
Check transmission oil (add to filler plug level as needed)		X *	
Check cooling air screen	X *		
Lubrication points (see Lubrication Chart)	X *		
Check generator-starter mounting bolts		X	
Check for belt wear			X
* Varies depending on operation conditions, climate etc.			

LUBRICATION

Proper lubrication and regular maintenance will increase the operating life of your HUSKY and attachments. Negligence on the part of the operator in regard to lubrication or general maintenance can depreciate the dependability of this rugged and durable

vehicle. It is suggested that lubrication recommendations in this manual be followed. A lubrication schedule prepared by the operator would be beneficial.

The numerically listed locations on the lubrication chart correspond to those numbers shown on Figures 19 and 20.

LUBRICATION CHART

LOCATION	TYPE OF LUBRICATION	AMOUNT OF LUBRICATION	FREQUENCY OF LUBRICATION
1. Wheel Bearings	Wheel Bearing Grease	Pack	Once a year
2. Front Wheel Spindles	Gun Grease	As Req'd.	10 hrs.
3. Front Axle Pivot	Gun Grease	As Req'd.	10 hrs.
4. P.T.O. Housing	Gun Grease	As Req'd.	10 hrs.
5. Air Cleaner	See Engine Manufacturer's Manual		
*6. Speed Lock Pivot	Oil	Coat surfaces	25 hrs.
*7. Disc Brake Linkage	Oil	Coat surfaces	25 hrs.
●*8. Hydrostatic Transmission	Automatic Transmission Fluid - Type A	Add to plug level	Check once a week or 25 hrs.
9. Transmission Filter			Change every 300 hrs. or with oil change
10. Hood Hinge	Oil	Coat surfaces	25 hrs.
11. Generator-Starter	No lubrication required		
*12. Universal Joints	Gun Grease	One stroke of grease gun	8 hrs.
13. Pivot Shaft	Gun Grease	One stroke of grease gun	8 hrs.
*14. Speed Control Pivot	Oil	Coat surfaces	25 hrs.
*15. Engine Crankcase	See Engine Manufacturer's Manual		
● Capacity 10 quarts. See your dealer for specified oil for complete refills. * More frequent if application demands. NOTE: Hand type grease gun recommended when greasing your unit. Hi-pressure type grease guns could cause damage to the fittings. Lubricate all linkages, levers and pins not equipped with grease fittings with an oil can once a week.			

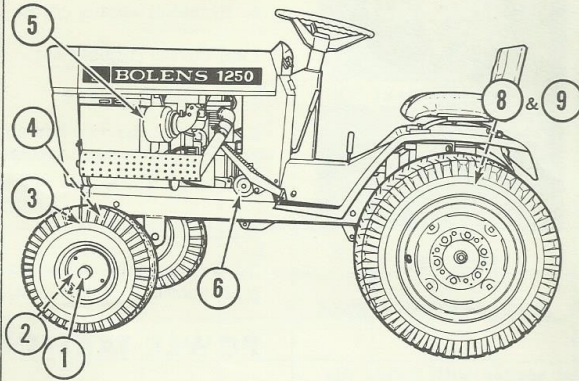
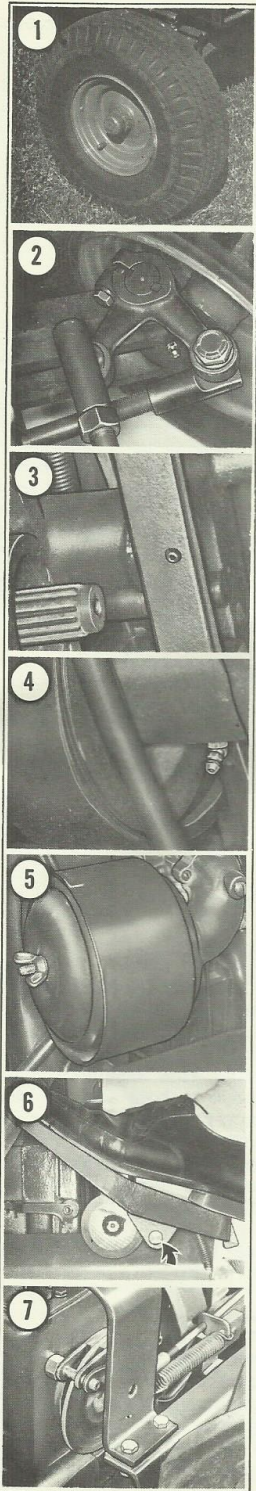

Figure 19

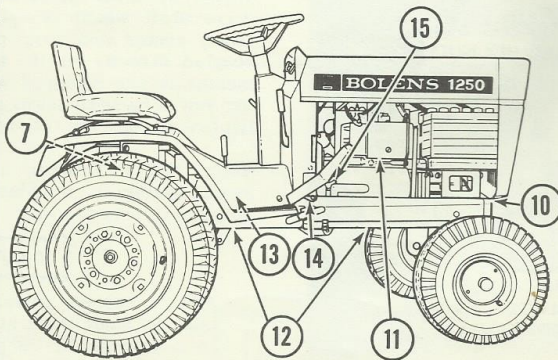
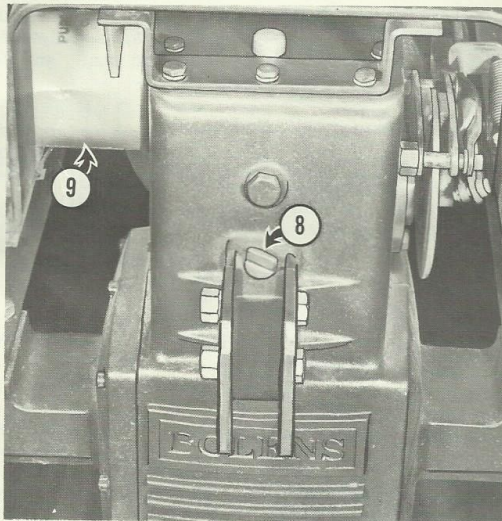
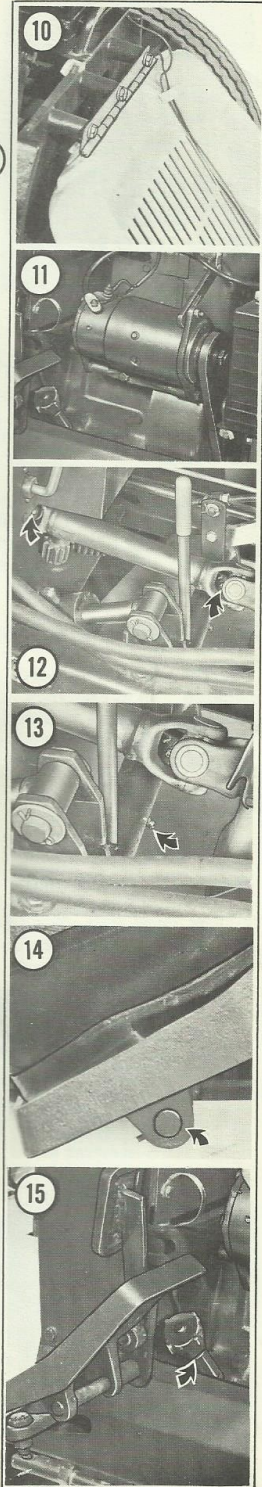

Figure 20



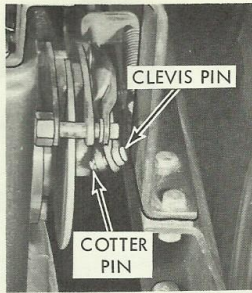

Figure 21

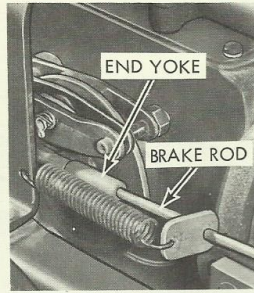

Figure 22

travel is attained before pedal depression gives braking action.

3. Reinstall clevis pin and secure with cotter pin.

NOTE

Before adjusting, inspect disc brake assembly to determine whether an adjustment is needed or if brake pad replacement is necessary. For disc brake service, consult your Bolens dealer.

SEAT ADJUSTMENT (4 positions available)

The 1250 tractor features adjustable seat spring suspension. Leaf springs can be added or removed from the seat as desired by the operator. If additional leaf springs are desired, order them through your Bolens dealer.

Seat Adjustment

1. Tilt seat forward.
2. Remove spring cotter pins shown in Figure 23.
3. Lift seat; using one of the two holes provided, position adjusting blocks as shown in Figure 23 for the

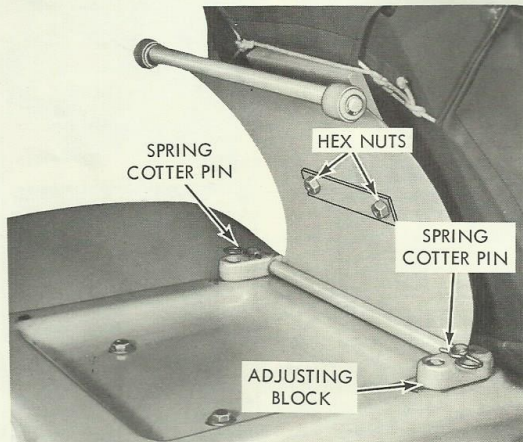

Figure 23

front two seat positions. To move seat back, rotate adjusting blocks 180 degrees.

4. Reinstall spring cotter pins.

Leaf Spring Adjustment

1. Tilt seat forward.
2. Remove the two hex nuts shown in Figure 23, then add or remove leaf springs as desired.
3. Reinstall hex nuts and tighten securely.

Seat Removal

To remove the seat, remove the two spring cotter pins shown in Figure 23, and lift seat from tractor.

POWER TAKE-OFF (P.T.O.)

Drive shaft delivers power directly from power-take-off (P.T.O.) to attachment--front, rear and center-mounted. Switching powered attachments requires only a short time. Slide universal joint over end of splined power-take-off shaft, align holes in joint and shaft, and secure with special cotter pin.

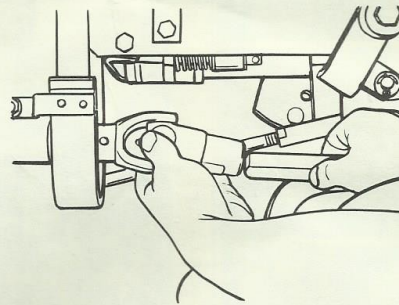

Figure 24

Slide attachment drive and P.T.O. drive shaft universal joint together; install pins into hitch points. The P.T.O. (power-take-off) drive shaft is located under the front of the tractor frame and is connected to the engine by three drive belts. This assembly has a drive shaft which is splined at both ends so that front, center and rear power attachments can be coupled directly to it. Universal joints on the attachments are equipped with needle-bearings allowing you to raise or lower attachments (with hydraulic lift lever) while the tractor is under full power.

Your HUSKY Tractor has the fastest attachment switch system in the industry. No belts to install. . . no special tools needed.

CAUTION

Always remove universal joint from power-take-off shaft when attachments are removed from tractor. If the joint is not removed and the power-take-off is engaged, damage will result from whipping action of the free joint.

MINOR TROUBLE SHOOTING GUIDE

IF TRACTOR ACTS IN FOLLOWING MANNER:	CHECK FOR POSSIBLE CAUSE									
	FAULTY IGNITION*	FAULTY SPARK PLUG	EMPTY FUEL TANK	BATTERY	CARBURETOR	IDLE ADJUSTMENT	OIL	AIR CLEANER	CHOKE	SEE YOUR BOLENS DEALER
Engine will turn over but won't start	X	X	X		X				X	X
Engine will not turn over				X						X
Starts only after repeated tries	X	X			X				X	X
Stalls in a few seconds			X		X	X				X
Stalls when hot	X	X	X		X	X		X		X
Idles rough	X					X			X	X
Engine overheats	X						X			X

*See Engine Manual or your Bolens Dealer.

WIRING DIAGRAM

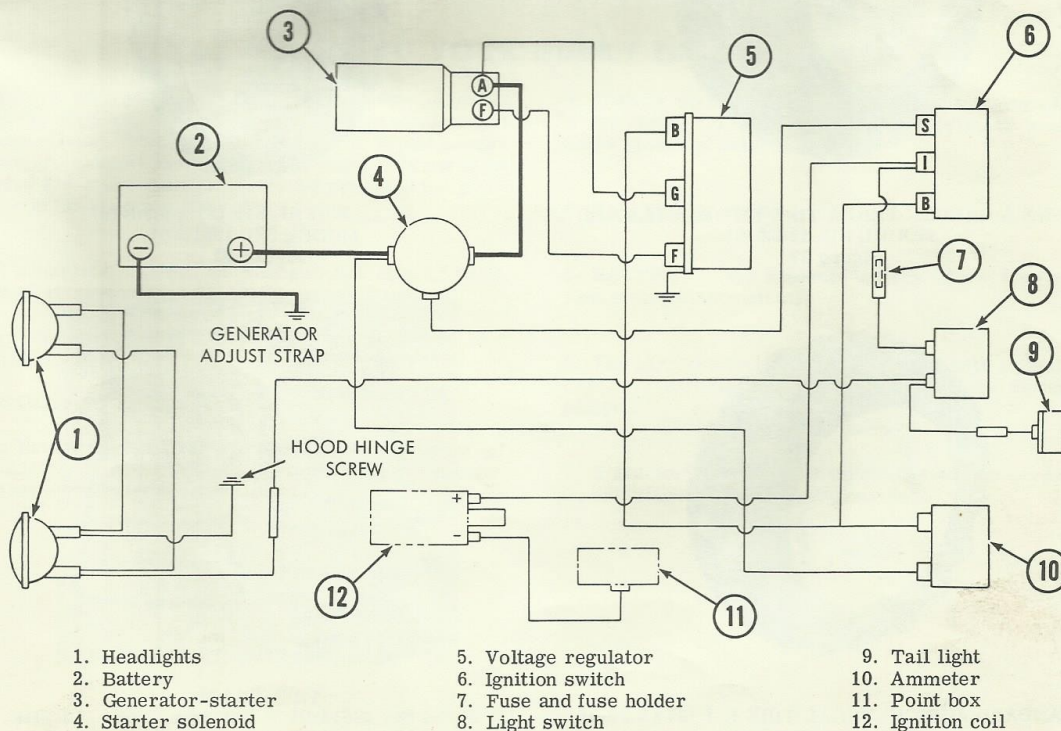
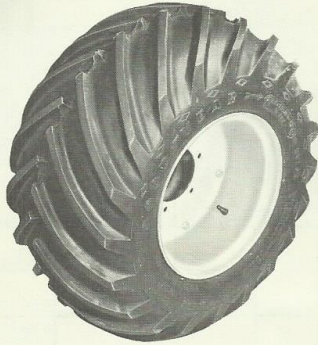

Figure 25

OPTIONAL EQUIPMENT



TERRA TIRE KIT (26 x 12.00-12)
MODEL NO. 19616-01
Figure 26



STANDARD LAWN & GARDEN TIRE KIT
(27 x 8.50-15)
MODEL NO. 19621-01
Figure 29

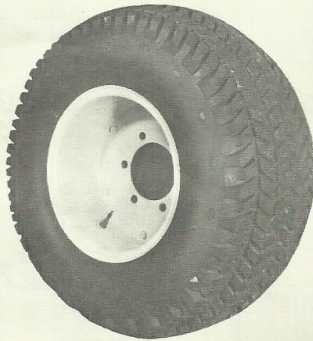

LAWN & GARDEN TERRA TIRE KIT (26 x 12.00-12)
MODEL NO. 19620-01
Figure 27



DUAL WHEEL KIT (27 x 8.50-15)
MODEL NO. 19619-01
Figure 30



STANDARD AGRICULTURAL TIRE KIT (27 x 8.50-15)
MODEL NO. 19615-01
Figure 28

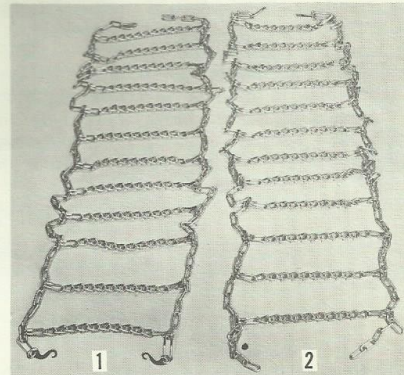

TIRE CHAINS
(1) Model No. 19614-01 - For 26 x 12.00 - 12 Tire
(2) Model No. 19613-01 - For 27 x 8.50 - 15 Tire
Figure 31

WHEEL WEIGHT KIT

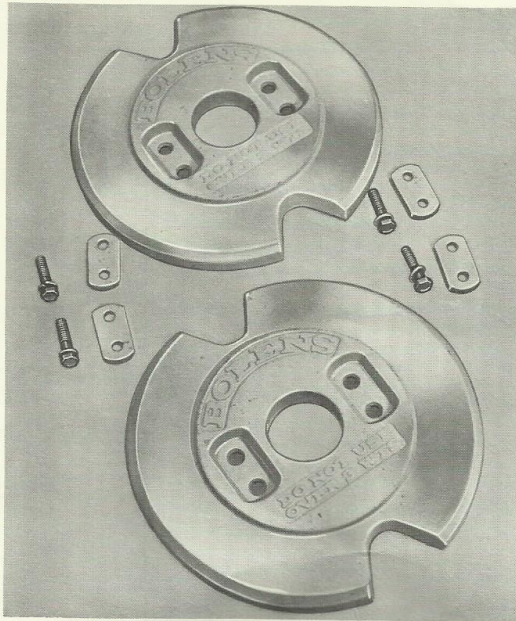

Figure 32

Three wheel weights can be attached to one wheel if desired. (See Figure 33.)

CAUTION

Do not install more than three wheel weights to one wheel.

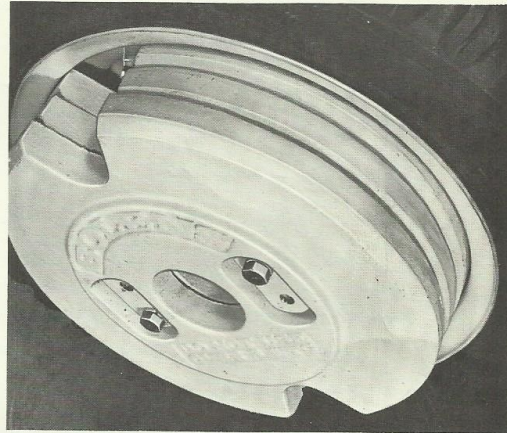

Figure 33

STORING YOUR HUSKY TRACTOR

Always keep your HUSKY tractor in a dry protected place when not in use to prolong its usefulness and appearance. With year round use, it is not necessary to "store" the tractor; but when it is not to be used for some time, it should be prepared for storage in the following manner:

1. Completely clean all accumulated dirt or trash from all parts.
2. Wipe oil or a rust preventative on any parts that may rust.
3. Drain gas tank and carburetor.
4. Remove spark plug and put a small amount of oil (SAE 30) in cylinder head. Consult Engine Manufacturer's Manual.
5. Without starting the tractor, turn the engine over a few times to fully lubricate the cylinder walls, valve seats and valve stems.
6. Keep tractor covered.
7. BATTERY - See separate battery folder, for correct storage instructions.
8. The air cleaner should be sealed off with a plastic bag or facsimile, for the duration of the storage period.
9. If tractor is stored with an attachment mounted on it, the attachment MUST be grounded.

LUBRICATION & MAINTENANCE RECORD

Date Performed	Description of Maintenance	Hours Run

LUBRICATION & MAINTENANCE RECORD

Date Performed	Description of Maintenance	Hours Run

WARRANTY

Bolens equipment is carefully engineered to give efficient and trouble free performance if properly operated and maintained. To help assure delivery of equipment in proper operating condition, we have obligated our dealers to completely assemble and service the tractor before delivery and thoroughly explain its operation to you. To take advantage of the owner's warranty issued with each tractor, you must fill out and return the Warranty Card to Bolens Division. With the warranty in effect, the Bolens dealer is authorized to repair or replace any parts which fail due to defective material or workmanship during the prescribed warranty period. However, all repair work must be performed by an authorized Bolens dealer or the warranty is void and all claims for warranty are subject to approval by the factory. The engine, battery, and other trade accessories are warranted separately by their respective manufacturers. Service can be obtained through your Bolens dealer.



BOLENS

PORT WASHINGTON WISCONSIN, U.S.A.