



▲ SAFETY MESSAGE ▲

The product for which you have requested information or replacement parts is not a current product. The replacement models incorporate product designs, safety features, safety instructions or warnings which represent the latest "State Of The Art" developments. For your safety and those around you please contact your nearest Ariens/Gravelly Dealer for a demonstration of the current product safety provisions and features.

PROFESSIONAL 24-G TRACTOR OPERATOR'S MANUAL

NOTE

Read this manual carefully and learn to operate and service your tractor before using it.

To keep the warranty, the tractor must be maintained and operated as directed in this manual.

All references to "left-side", "right-side", "front" and "back" are given from the operator's position.

Use the serial numbers to ensure prompt and correct service when ordering parts, requesting service or making inquiries.

TRACTOR SERIAL NUMBER: _____

ENGINE SERIAL NUMBER: _____

ENGINE SPEC NUMBER: _____



Look for this symbol to point out important safety precautions. It means -- ATTENTION! BECOME ALERT! YOUR SAFETY IS INVOLVED.

CONTENTS

1. INSTRUCTIONS FOR SAFE OPERATION
2. CONTROLS
3. OPERATING INSTRUCTIONS
4. SERVICE INSTRUCTIONS
5. STORAGE
6. PROBLEM SOLVING
7. SPECIFICATIONS AND WIRING
8. SET-UP INSTRUCTIONS
9. WARRANTY

SECTION 1

INSTRUCTIONS FOR SAFE OPERATION

Improper use of this tractor can injure people and damage the equipment. People using or servicing this tractor must read and follow the instructions in this manual.

It is important to understand that this manual and any other Gravely instruction manuals do not cover every possible danger. It is impossible for Gravely to know all possible dangers in operating and servicing the tractor and attachments.

The purchaser must give these instructions to the people operating and maintaining this tractor. These people must use eye and foot protection.

1.1 Preparation:

1. Read this manual and the attachment operator's manuals carefully.
2. Learn the location and function of all tractor and attachment controls.
3. Learn how to use the controls to stop the tractor and attachment quickly.
4. Use caution with gasoline. Gasoline is very flammable. Keep it in a clean and tight container away from flames or hot items. Never put gasoline in the fuel tank while the engine is running or hot. Clean up spilled gasoline before starting engine.
5. Be certain that all shield, guards, and interlock switches are in the correct positions.
6. When hauling the tractor, connect the chassis and rear hitch to the transporting vehicle. Never connect from control levers, rods, or like items that could be damaged.
7. Inspect area to be mowed and remove all material which could be thrown by the mower.

1.2 Operation:

1. Wear foot and eye protection. Do not wear loose clothing.
2. Do not use the tractor in the dark without adequate lighting.
3. Keep the tractor in good condition. Maintain it as directed in this manual.
4. Replace all parts that become damaged or lost.
5. **USE ONLY GRAVELY ACCESSORIES AND ATTACHMENTS OR ATTACHMENTS GRAVELY HAS APPROVED FOR USE WITH THIS TRACTOR.**

6. Do not overspeed the engine. Do not override the governor.
7. Keep away from moving parts.
8. Keep people and animals away from the operating area.
9. Do not let people other than the operator near the operating equipment.
10. Use a slow speed and engage the forward-reverse control lever slowly when operating on slopes.
11. Look for and keep away from hazards.
12. Before starting the engine, put the forward-reverse lever in the "NEUTRAL" position and the PTO control in the "OFF" position.
13. Look behind when operating in reverse. Look for people and hazards.
14. After hitting an object, stop the equipment and engine. Check for and repair any damage before operating.
15. Operate the tractor only from the operator's position, on the seat.
16. Travel up and down slopes, not across.
17. Never permit children to operate the tractor.
18. Before leaving the operator's position, put the PTO control in the "OFF" position, lock the brake or put in gear and engage the forward-reverse lever, and remove the ignition key. Wait until all moving parts have stopped.
19. If there is a sudden change in the sound or vibration of the equipment, stop the engine and check for damage. Repair any damage or failure before continuing operation.
20. Never run the engine indoors except to move it outside. Exhaust fumes are dangerous.
21. Go slowly on slick surfaces.
22. Follow traffic laws when operating on or near a road.
23. Before making adjustments or servicing, move the PTO to "OFF", turn the ignition switch to "OFF" and wait until all moving parts completely stop.

SECTION 2

CONTROLS

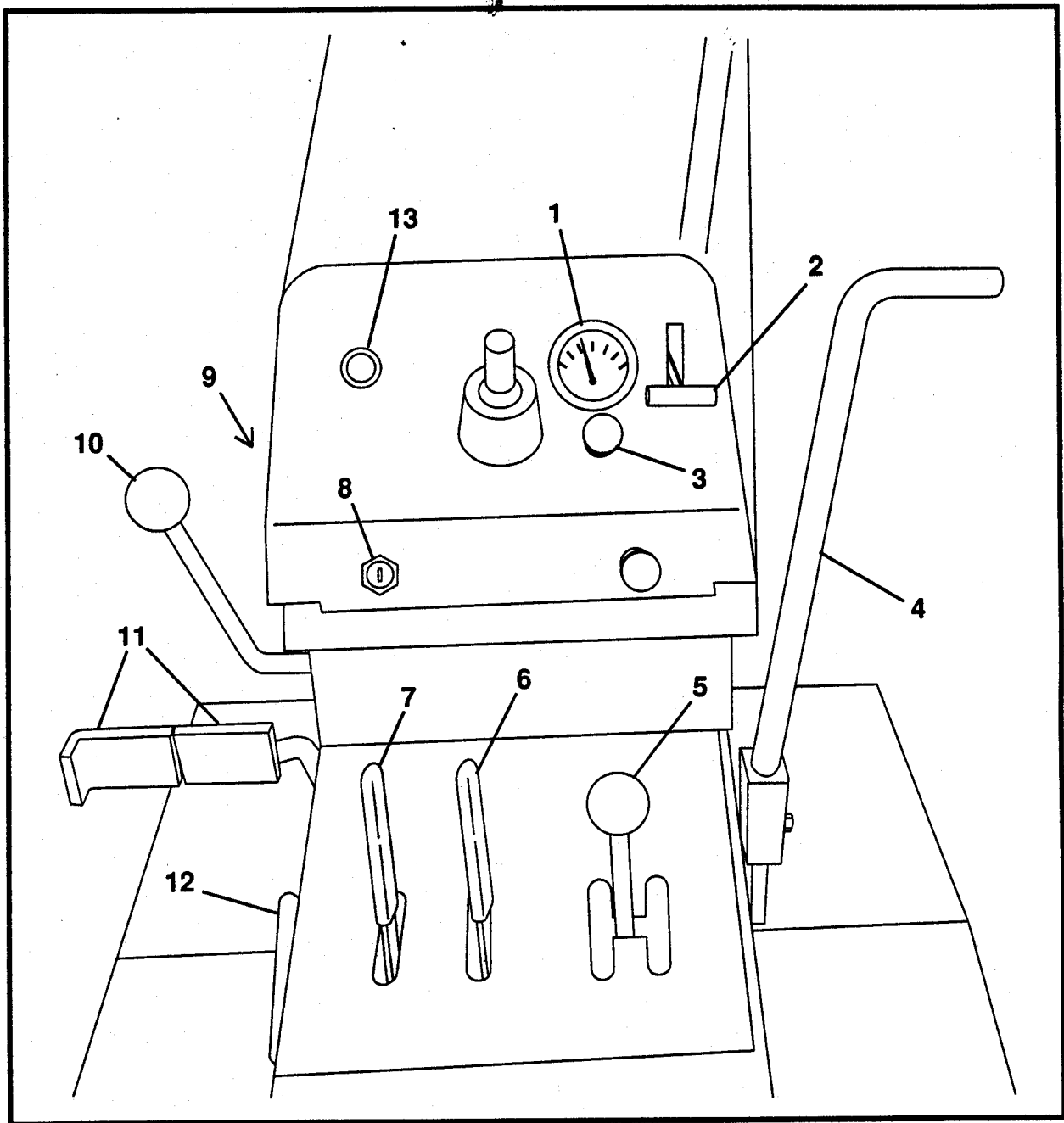

1 - Ammeter

2 - Throttle Control

3 - Choke Control

4 - Fwd-Rev Lever Weldment

5 - Gear Selector

6 - Range Selector

7 - PTO Control

8 - Ignition Switch

9 - Hourmeter

10 - Hydraulic Lift Control

11 - Brake Pedal

12 - Brake Lock Lever

13 - Warning Light(Oil Pressure
and Temperature)

FIGURE 1

SECTION 3

OPERATING INSTRUCTIONS

Read this manual before operating the tractor. Read the Operator's Manual for any attachment that is to be used.

From the tractor seat, note the location of the tractor and attachment controls (See Section 2.). **ALWAYS BE IN THE SEAT WHEN OPERATING THE TRACTOR OTHER THAN IN STATIONARY APPLICATIONS.**

3.1 Before Starting the Engine

Be sure that the tractor and engine have been properly serviced and maintained.

3.2 Starting and Stopping the Engine

To start the engine:

1. The forward-reverse lever must be in "NEUTRAL" position and the PTO control must be at "OFF" position.
2. Put the key in the ignition switch.
3. Move the throttle lever to a middle position.
4. If the engine is cold, move the choke lever to "ON". If the engine is warm, the choke lever should be at "OFF".
5. Turn the ignition key to "START". When the engine starts, move the choke lever slowly to "OFF". If the engine does not start in five seconds, release the key for a few seconds and then repeat. If the engine does not start within five tries, see Section 6 for instructions.



CAUTION: Do not keep the starter running for over 15 seconds. Do not run the starter for more than 15 seconds in any one minute.

To stop the engine:

1. Move the throttle lever to "SLOW" and idle with the PTO control disengaged for approximately 15 seconds.
2. Turn the ignition switch to "OFF".
3. Remove the key before leaving the tractor.

3.3 Operating the Transmission

Use slow engine and transmission speeds until you know how to operate the tractor safely.

 **CAUTION:** DO NOT SHIFT TRANSMISSION GEARS WHILE THE FORWARD OR REVERSE CLUTCHES ARE ENGAGED OR THE TRACTOR IS MOVING. This will damage the gears. Always place the forward-reverse lever weldment in "NEUTRAL" and bring the tractor to a complete stop before moving the gear or range selectors.

1. To Move in a Forward Direction

- A. Start the engine and move the throttle to give the desired engine speed.
- B. Put the range and gear selectors in the positions that will produce the desired speeds. See Section 7 for ground speeds produced.
- C. Move the forward-reverse lever weldment forward. As the tractor increases speed, push the lever until it locks into position. If the lever is not pushed all the way forward, slippage can damage the forward clutch. **USE CAUTION WHILE LEARNING TO OPERATE THE FORWARD-REVERSE LEVER WELDMENT.**

NOTE: The operator must be in the seat to operate the forward-reverse lever. If the operator leaves the seat with the forward-reverse lever in the "FORWARD" position, the engine will stop.

2. To Move in a Reverse Direction

- A. Follow Steps A and B under Number 1 above.
- B. Move the forward-reverse lever weldment rearward. The lever does not lock into a reverse position. You must continue to hold the lever in the "REVERSE" position to continue reverse travel. The lever will return to "NEUTRAL" upon release.

3. Stopping the Tractor

Pushing the brake pedal down will stop the tractor and return the forward-reverse lever to "NEUTRAL". Use the brake pedal for sudden stops and for holding the tractor on slopes.

4. Locking the Brake

To lock the brake for parking, depress the brake pedal and pull back on the brake lock lever. To release, push on the pedal and move the lock lever forward.

5. Using the PTO

To power an attachment, push the PTO control forward to "ON". To stop an attachment, pull the PTO control rearward to "OFF". The operator must be in the tractor seat to operate the PTO. If the operator leaves the seat while the PTO control is in the "ON" position, the engine will stop.

6. Correct Operating Speeds

 **WARNING:** On rough and sloping ground and when mowing and trimming near buildings, trees, and other obstructions, use a slow ground speed.

NOTE: Most attachments, especially rotary mowers and snowblowers perform best when operated at full engine speed. Proper ground speed is determined by power limitations, the type of terrain, the quality requirements of the job being performed, obstructions, hazards, etc.

3.4 Using the Attachment Lift System

The hydraulic lift system is used to raise and lower attachments. It can hold an attachment in position or let it follow the ground.

1. To hold an attachment in position:

- A. Lift the attachment by pulling back on the hydraulic lift lever until the attachment is fully raised.
- B. Lower the attachment to the desired position by gently pushing the lift lever forward.
- C. When the attachment reaches the desired position, release the lever. The attachment will be held in that position.

2. To let an attachment follow the ground:

Push the hydraulic lift lever all the way forward to the "FLOAT" position. The attachment will be lowered to the ground and the lever will remain at that position until you pull it backwards.

3.5 Warning Light

This tractor is equipped with a warning light to alert the operator in the event there is a problem with the engine. The warning light is located on the upper left side of the instrument panel. See Figure 1.

NOTE: The light is activated by two different switches on the engine:

- a. Oil Pressure Switch - when there is a loss of oil pressure.
- b. Metal Temperature Switch - when the engine overheats.

If the light comes on while operating the tractor, stop the tractor and engine as quickly as possible. Check the following items on the engine:

1. Check the engine oil level.
2. Remove the engine shrouds and clean the cooling fins of any blockage.
3. Check the engine for external damage.

To check to see if the light is operating correctly, turn the ignition switch to the "ON" position. The light should glow red.

NOTE: The engine must have been off for at least five minutes prior to performing this test.

SECTION 4

SERVICE INSTRUCTIONS

Correct maintenance can increase the life of the Professional 24-G. It is important that the items shown in Chart 1 be done at the correct time intervals. Use Chart 2 to record the actual hours on the hourmeter and the date at which each service item is performed.

MAINTENANCE SCHEDULE				
SERVICE PERFORMED	TIME INTERVALS BETWEEN SERVICE			
	DAILY	25 HR.	200 HR.	500 HR.
General Lubrication (Section 4.2)		X		
Check the Engine Oil (Section 4.3)	X			
Check the Battery Fluid (Section 4.5)			X	
Check the Battery (Section 4.5)			X	
Check the Fasteners (Section 4.6)		X		
Check the Air Intake Screen (Section 4.7)	X			
Check the Engine Cooling System (Section 4.8)		X		
Check the Air Cleaner (Section 4.9)	X			
Check the Transmission Oil (Section 4.11)			X	
Check the Tire Pressure (Section 7)		X		

CHART 1

4.1 Filling the Fuel Tank

 **WARNING:** Gasoline is very flammable. Follow the safety instructions shown in Section 1.

Gasoline is added as required. Use clean lead free or regular grade gasoline. To add gasoline:

1. Put the tractor in an open area.
2. Stop the engine and lock the brake.
3. Clean the fuel cap area.
4. Remove the fuel tank cap.
5. Fill the tank with gasoline. Use caution. Do not overflow.
6. Reinstall fuel tank cap.
7. If gasoline is spilled, wipe it up.

MAINTENANCE RECORD

SERVICE TO BE PERFORMED	TIME INTERVALS BETWEEN SERVICE	
	ACTUAL HOURS	DATE
General Lubrication	25 HRS.	
	ACTUAL HOURS	
Check the Fasteners	50 HRS.	
	ACTUAL HOURS	
Check the Engine Cooling System	75 HRS.	
	ACTUAL HOURS	
Check the Tire Pressure	100 HRS.	
	ACTUAL HOURS	
Check the Transmission Oil	125 HRS.	
	ACTUAL HOURS	
Check the Battery and Battery Fluid	150 HRS.	
	ACTUAL HOURS	
	175 HRS.	
	ACTUAL HOURS	
	200 HRS.	
	ACTUAL HOURS	
	225 HRS.	
	ACTUAL HOURS	
	250 HRS.	
	ACTUAL HOURS	
	275 HRS.	
	ACTUAL HOURS	
	300 HRS.	
	ACTUAL HOURS	
	325 HRS.	
	ACTUAL HOURS	
	350 HRS.	
	ACTUAL HOURS	
	DATE	

CHART 2

MAINTENANCE RECORD

SERVICE TO BE PERFORMED		TIME INTERVALS BETWEEN SERVICE	
		●	375 HRS.
			ACTUAL HOURS
			DATE
	●	●	400 HRS.
			ACTUAL HOURS
			DATE
	●	●	425 HRS.
			ACTUAL HOURS
			DATE
	●	●	450 HRS.
			ACTUAL HOURS
			DATE
	●	●	475 HRS.
			ACTUAL HOURS
			DATE
	●	●	500 HRS.
			ACTUAL HOURS
			DATE
	●	●	525 HRS.
			ACTUAL HOURS
			DATE
	●	●	550 HRS.
			ACTUAL HOURS
			DATE
	●	●	575 HRS.
			ACTUAL HOURS
			DATE
	●	●	600 HRS.
			ACTUAL HOURS
			DATE
	●	●	625 HRS.
			ACTUAL HOURS
			DATE
	●	●	650 HRS.
			ACTUAL HOURS
			DATE
	●	●	675 HRS.
			ACTUAL HOURS
			DATE
	●	●	700 HRS.
			ACTUAL HOURS
			DATE

CHART 2(CONTINUED)

4.2 General Lubrication

There are five grease fittings to be greased at 25-hour intervals. Clean the fittings before attaching the grease gun. Use a multi-purpose grease. Add grease until it appears at the ends of the bearings. The locations of the five fittings are:

1. On the brake pedals.
2. On the front axle at each king pin.
3. On the front axle as shown in Figure 2.

Apply motor oil to all pin connections, pivot points and areas where sliding occurs in the clutch, transmission, PTO, and lift control systems every 25 hours.

4.3 Checking the Engine Oil

Check the engine oil level daily. Never operate the engine with the oil level below the low mark on the dipstick. See your engine manual for oil specifications and oil filter service instructions.

To check the oil level:

1. Clean around the dipstick to prevent dirt from entering the tube.
2. Remove the dipstick and wipe off the oil.

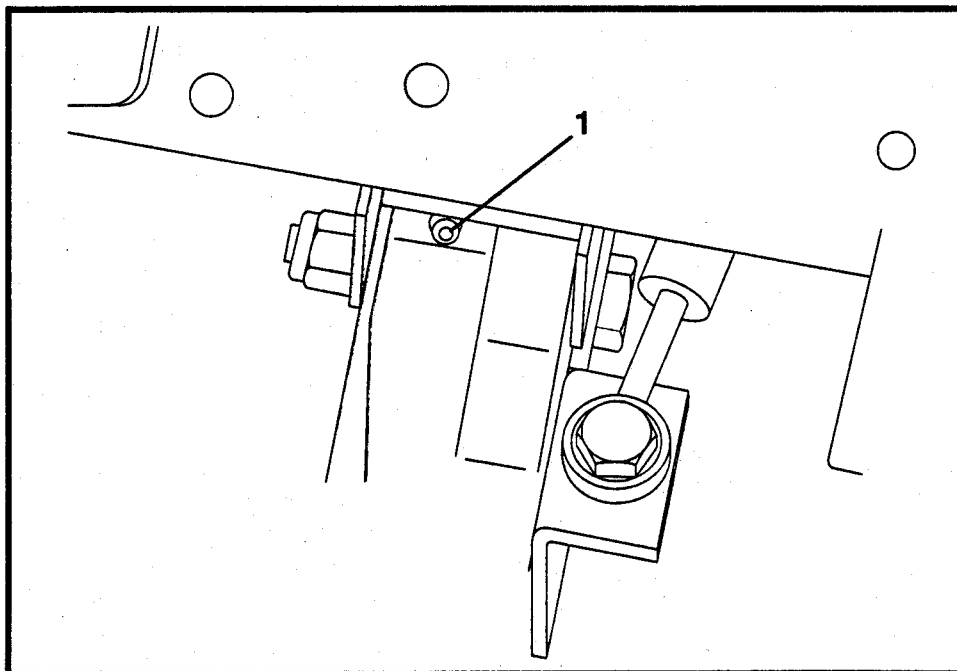

1 - Grease Fitting on the Front Axle
FIGURE 2

3. Put the dipstick back in place. Be sure it is all the way down.
4. Remove the dipstick again and note oil level.
5. Add oil, if needed. Do not overfill.
6. Repeat Step 3.

4.4 Changing the Engine Oil

1. Read your engine manual for recommended change schedule.
2. Move the tractor to a level area. Lock the brake.
3. If the engine is cold, let it run for 5 minutes.
4. When the engine is warm, stop it and raise the rear fender.



WARNING: Engine muffler and other parts are hot.

5. Clean the areas around the dipstick and drain plug.
6. Remove the dipstick.
7. Put an open top container that will hold four quarts under the drain plug.
8. Remove the drain plug.
9. Allow the engine to drain completely.
10. Clean and reinstall the drain plug.
11. Remove the oil filter (some models), clean the oil filter port and install a new oil filter according to the instructions on the oil filter.
12. Fill with new oil to the "FULL" mark on the dipstick.
13. Replace the dipstick. Lower the rear fender.
14. Start the engine and check for leakage at the drain plug. Tighten the plug if leakage occurs.

4.5 Checking the Battery Fluid

Check the battery fluid every 200 hours. Use caution and wear eye protection when checking the battery. To check the battery:

1. Clean the top of the battery.

2. Lift the filler caps.
3. If the fluid level is below the split rings in the filler tube, add distilled water. Do not fill above the split ring. Do not use a metal funnel.
4. Reinstall the filler caps. Push them all the way down.

4.6 Checking the Fasteners

Each day before operating, check all nuts, bolts, and other fasteners. Replace fasteners that are missing or damaged. Tighten all nuts and bolts to the torque shown in Chart 3 unless shown differently.

BOLT TORQUE SPECIFICATIONS		
BOLT SIZE	FOOT POUNDS (ft.lbs.)	NEWTON METERS (N.m)
1/4"	7	9.5
5/16"	14	19
3/8"	25	34
7/16"	40	54
1/2"	60	82
9/16"	83	113
5/8"	120	163
3/4"	200	271

CHART 3

4.7 Checking the Air Intake Screen

Check the air intake screen on the engine each day. Remove any grass, dirt, or debris that may have accumulated on it. **THE AIR INTAKE SCREEN MUST BE KEPT CLEAN.**

4.8 Checking the Cooling System

Check the cooling system for signs of the collection of grass and debris in the engine cooling fins every 25 hours or more often when operated in dirty conditions. See your engine manual for instructions.

4.9 Checking the Air Cleaner

Check the air cleaner each day. See your engine manual for instructions.

4.10 Changing the Air Cleaner Element

Replace the air cleaner element at the correct intervals. See your engine manual for instructions.

4.11 Checking the Transmission Oil

Check the transmission oil level every 200 hours or twice a year, whichever comes first. If leakage is observed, check more frequently. The fill tube and check plug are shown in Figure 3. To check the transmission oil level:

1. Move the tractor to a level area. Stop the engine and lock the brake.
2. Raise the rear fender.
3. Clean the check plug and remove it.
4. The oil level is correct when oil is at the bottom of the hole.
5. If the level is correct, reinstall and tighten the plug. If the level is low, add oil. See Section 7 for recommended lubricant specifications.

To add oil:

1. Remove the fill tube cap.
2. Add oil until it reaches the bottom of the check plug hole.
3. Reinstall and tighten the fill tube cap and check plug.

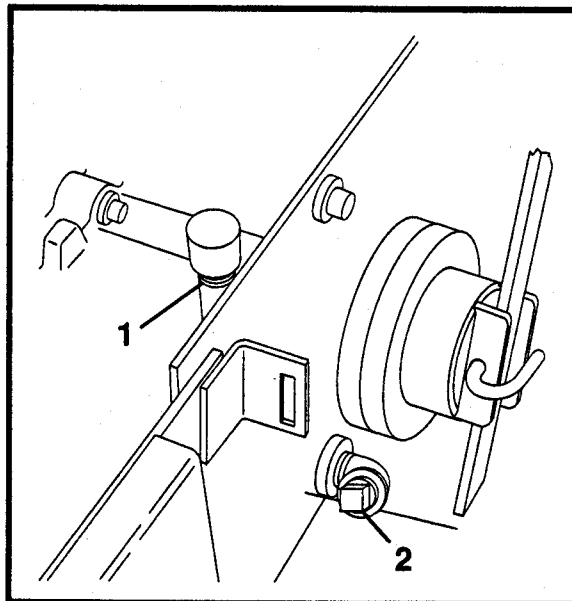

1 - Fill Tube
2 - Check Plug
FIGURE 3

4.12 Servicing the Brakes

After each use of the tractor, wash the dirt from the brakes with water. Each day before operating, check all nuts, bolts, and other fasteners. Replace fasteners that are missing or damaged. Tighten all nuts and bolts to the torque shown in Chart 3 unless shown differently.

NOTE: Do not use harsh or abrasive cleaners on any painted surface. Do not allow gasoline or oil to remain on any silk screened surface.

Brake service is required if the brakes do not stop and hold the tractor effectively. The brakes should be effective enough to cause the rear wheels to slide if applied suddenly on a concrete or asphalt surface.

1. Brake Adjustment

As necessary to compensate for brake lining wear, adjust the brake linkage as follows:

- A. Stop the tractor on a level surface.
- B. Stop the engine and block the wheels so the tractor cannot roll.
- C. Remove the cotter pin and clevis pin holding the brake control rod clevis to the cam lever arm on the left individual wheel brake. See Figure 4.

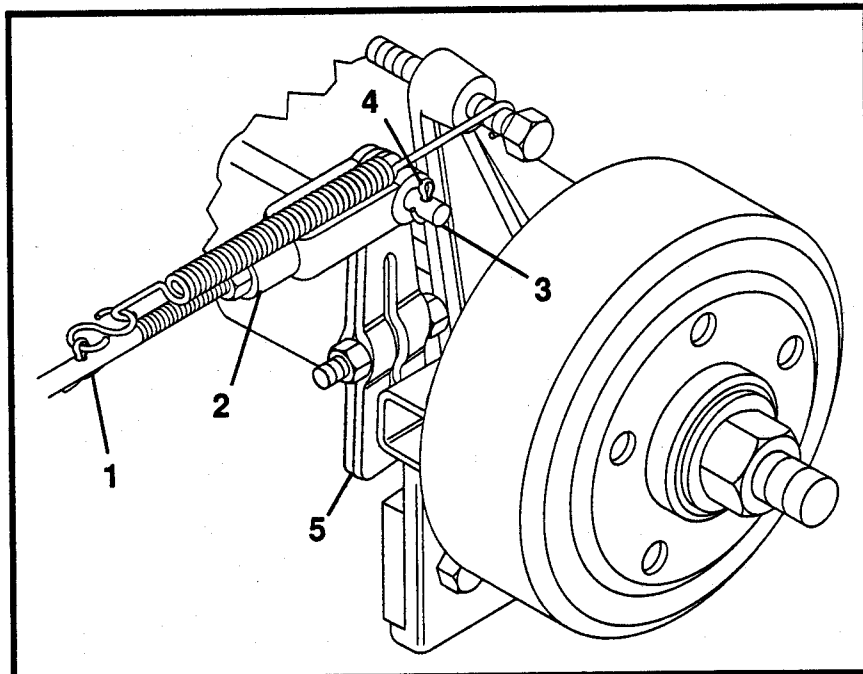

- | | |
|-----------------------|-------------------|
| 1 - Brake Rod | 4 - Cotter Pin |
| 2 - Adjustable Clevis | 5 - Cam Lever Arm |
| 3 - Clevis Pin | |

FIGURE 4

- D. With the left brake pedal all the way up, turn the clevis on the brake control rod until the hole in the clevis is aligned with the hole in the cam lever arm.
- E. Fasten the brake control rod clevis to the cam lever arm with the clevis pin and cotter pin.
- F. Carefully test the operation of the left individual wheel brake. If necessary, repeat the above procedures to get the correct braking action.
- G. Follow the above procedures for the right individual wheel brake.
- H. Make sure that the pedal travel is equal for both brakes.



WARNING: Replace the brake shoes before the lining is worn to the rivet heads.

- I. If the correct braking action cannot be achieved after performing the above procedures, do the following:
 - a. Loosen the 5/16-24 nut and bolt which fastens the cam lever arm to the brake cam.
 - b. Remove the cam lever arm from the brake cam. Rotate the cam lever arm one spline to the rear and put it back on the brake cam.
 - c. Move the cam lever arm all the way to the front. Then rotate the tip of the cam lever arm 3/4 inches toward the rear.
 - d. Repeat Steps A through F.

2. Brake Inspection and Repair

- A. Raise and block the rear of the tractor.
- B. Remove the rear wheels and brake drums.
- C. Inspect the brake parts and linkage. Replace any parts worn or damaged.
- D. Reverse the disassembly procedure. See Section 4.12.1 for adjustment.

4.13 Servicing the Forward and Reverse Clutches

The forward and reverse clutches must be checked every 100 hours. If the lining has worn to a thickness of less than 0.150 inch (3.8mm), replace the lining. The forward clutch is on the right side of the transmission and the reverse clutch is on the left side of the transmission. See Figure 3.

NOTE: DAMAGE WILL OCCUR IF THE TRACTOR IS OPERATED WITH A LINING THICKNESS OF LESS THAN 0.150 INCH(3.8MM).

Inspect and adjust the clutches as follows:

1. Stop the engine and place the forward-reverse lever in the "NEUTRAL" position.
2. Raise the rear fender.
3. Measure the clearance in the slot. The correct clearance is .030 inch (.76mm) to .060 inch (1.5mm).
4. Adjust the bolts which go through the flange on the axle bearing retainer so that the forward-reverse clutch springs are straight up and down when the clutches have zero clearance. Lock the bolt in place with the jam nut. Loosen the jam nut which holds the slide rod bushing in place. Adjust the bushing on the slide rod until the clearance is correct. Lock the bushing in place with the jam nut.
5. Lubricate the clutch once each season. Remove the clutch and apply a film of multi-purpose grease to the splined clutch shaft. While the clutch is off, check the lining wear. If the lining has worn near the rivet heads, replace the lining. Re-adjust the clutch as described above.

4.14 Servicing the PTO Clutch

The PTO clutch adjustment should be checked every 100 hours. To check the adjustment and to adjust:

1. Stop the engine and lock the brake.
2. To check adjustment, move the PTO clutch lever forward until the gaps in the clutch pac are closed. (Light forward pressure on the PTO clutch lever.) Measure the distance between the front edge of the lever and the locking notch in the control cover plate. This dimension should be about 1 inch.
3. If adjustment is required, remove the control cover plate and push back on the end of the bar spring that loads the PTO clutch, until the gaps in the clutch pac are closed. (Push on the end of the spring on which the coil spring is located.) When the gaps in the clutch pac are closed, the bar spring should be straight across the frame.

NOTE: The bar spring will line up with the two flanges on the clutch trunnion. If it does not line up, adjust as necessary with the bolt in the bracket on the right side of the frame. Loosen the lock nut and turn the bolt until the spring bar is straight across. Tighten the jam nut.

4. Install the control plate and check the clutch adjustment as directed in Step 2 above.
5. If more adjustment is needed, loosen the two jam nuts on the rod that loads the compression spring. Turn the nuts toward the compression spring until the 1 inch dimension in Step 2 is achieved. Lock the jam nuts.

4.15 Servicing the Spark Plug(s)

To clean or change a spark plug:

1. Stop the engine, lock the brake, and raise the rear fender.
2. See your engine manual for further instructions.

4.16 Hydraulic Lift and Power Steering Service

Check the hydraulic fluid level each time the tractor is used. The hydraulic fluid tank is located under the hood. The fluid level should be slightly above the divider in the tank. Add fluid when necessary and check for leaks. The hydraulic fluid and filter should be replaced when:

- A. The tractor has been used one year commercially.
- B. The tractor has been used two years by a consumer.
- C. The hydraulic system has been repaired.

 **WARNING:** Thoroughly clean hydraulic fittings that are to be disconnected to keep contaminants out of the system.

To replace the hydraulic fluid:

1. Disconnect the suction hose at the fitting on the pump. This will drain the back half of the tank.
2. Disconnect the hose that goes from the lift valve to the tank at the fitting on the oil filter. This will drain the front half of the tank.
3. Change the hydraulic oil filter.
4. Reconnect both hoses and fill with clean hydraulic fluid. See Section 7 for hydraulic fluid specifications. The fluid level should be slightly above the divider in the tank.

4.17 Adjustment of Range Selector

1. Move the Hi-Lo shift lever as far as it will go both directions. Measure the distance between the lever and the end of the slot. This distance should not be less than 5/16".
2. Adjust the clevis so that the clearance between the Hi-Lo shift lever and control cover plate slot is equal for both positions of the lever.

SECTION 5

STORAGE

5.1 When the tractor will not be operated for more than two months:

1. Do the daily and 25-hour maintenance, but do not add gasoline.
2. Clean the tractor. Paint or oil bare metal surfaces to prevent rust.

NOTE: Do not use harsh or abrasive cleaners on any painted surface. Do not allow gasoline or oil to remain on any silk screened surface.

3. Refer to the engine manual and prepare the engine for storage.
4. Clean and charge the battery. Charge the battery every three or four weeks while in storage.
5. Place the PTO lever in the "OUT" position.
6. Store in a cool, dry place.

5.2 To use the tractor again:

1. Refer to the engine manual and prepare the engine for service.
2. Charge the battery.
3. Put fresh, clean gasoline in the fuel tank.

SECTION 6

PROBLEM SOLVING

OBSERVATION	POSSIBLE CAUSE
1. No sound or motion when the ignition switch is turned to the "START" position.	PTO control in the "ON" position Forward-reverse lever in the forward or reverse position Blown fuse Discharged battery Starting solenoid damaged Loose battery cable(s) Damaged time delay module
2. When the ignition switch is turned to "START", the solenoid "clicks" and the engine starter motor does not operate.	Discharged battery Battery cable connector(s) corroded Starter damaged
3. When the ignition switch is turned to "START", the starter operates but the engine does not start.	Relay or relay connection(s) Fuel tank empty Fuel valve turned off Engine spark plug(s) fouled Engine failure -- see Engine Service Manual
4. Battery discharged.	Regulator-rectifier failure Fuse holder or battery Engine alternator failure Battery failure
5. Engine continues to run when the ignition switch is rotated to the "OFF" position.	Ground wire not connected Ignition switch failure
6. Lights do not come on when the light switch is moved to the "ON" position.	Light(s) burned out Defective light switch Loose wire connections Engine light alternator failure Ignition switch failure
7. Engine runs rough or stops after it gets hot.	See Engine Service Manual Time delay failure
8. Fuse blows when starting engine.	Defective solenoid
9. Hydraulic lift will not lift attachment.	Hydraulic valve seals Cylinder seals Low fluid level Hydraulic pump

SECTION 7

SPECIFICATIONS AND WIRING

Fuel Specifications	See your engine manual
Fuel Tank Capacity	5.3 Gallons(U.S.) (20 liters)
Engine Oil Specification	See your engine manual
Engine Oil Capacity	See your engine manual
Transmission Oil Specification	API Service SC 10W-30 Motor Oil
Transmission Oil Capacity	6 Quarts(U.S.) (5.7 liters)
Hydraulic Fluid Specification	ATF Dextron II
Hydraulic Fluid Capacity	4 Quarts(U.S.) (3.8 liter)
Battery	12 Volt, BC1 group 22F, 42 amp. hr.
Fuse	30 amp. Acc-30
Weight	983 Lbs.(445.9 kg.)
Tire Sizes:	
Front	18 x 8.50-8
Rear	26 x 12.00-12
Tire Pressure:	
Front	14 psi(97 kN/m ²) to 18 psi(124 kN/m ²)
Rear	10 psi(69 kN/m ²) to 14 psi(97 kN/m ²)

Grounds Speeds (at 3600 rpm Engine Speed):

Gear	FORWARD		REVERSE	
	"LO" Range	"HI" Range	"LO" Range	"HI" Range
1	.6 mph (1.0 km/h)	2.8 mph (4.5 km/h)	1.2 mph (1.9 km/h)	Same
2	.8 mph (1.2 km/h)	4.2 mph (6.8 km/h)	1.9 mph (3.1 km/h)	Same
3	1.2 mph (1.9 km/h)	6.2 mph (10.0 km/h)	2.8 mph (4.5 km/h)	Same
4	1.9 mph (3.1 km/h)	9.4 mph (15.1 km/h)	4.2 mph (6.8 km/h)	Same

Wiring Diagram:

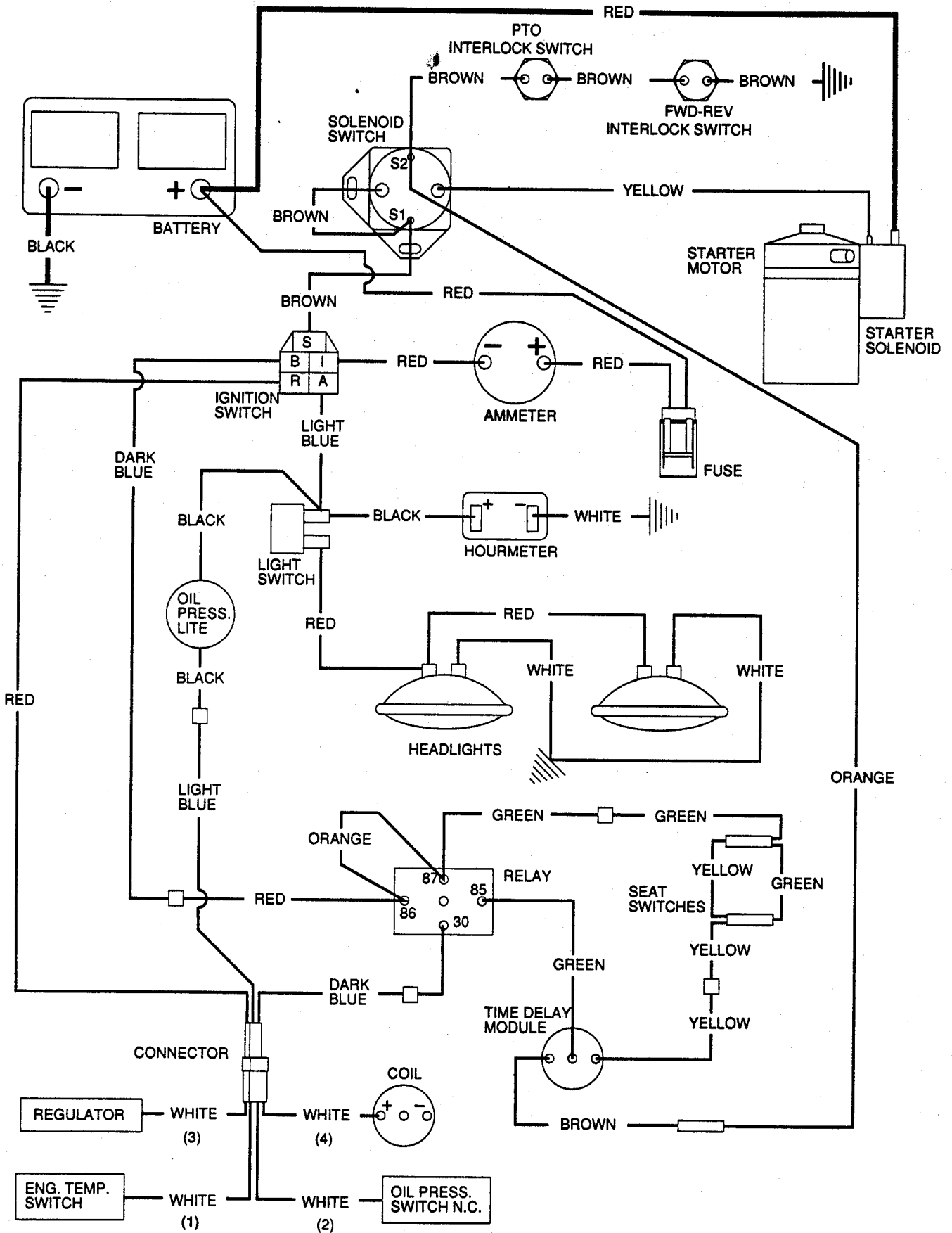

Hydraulic System Diagram:

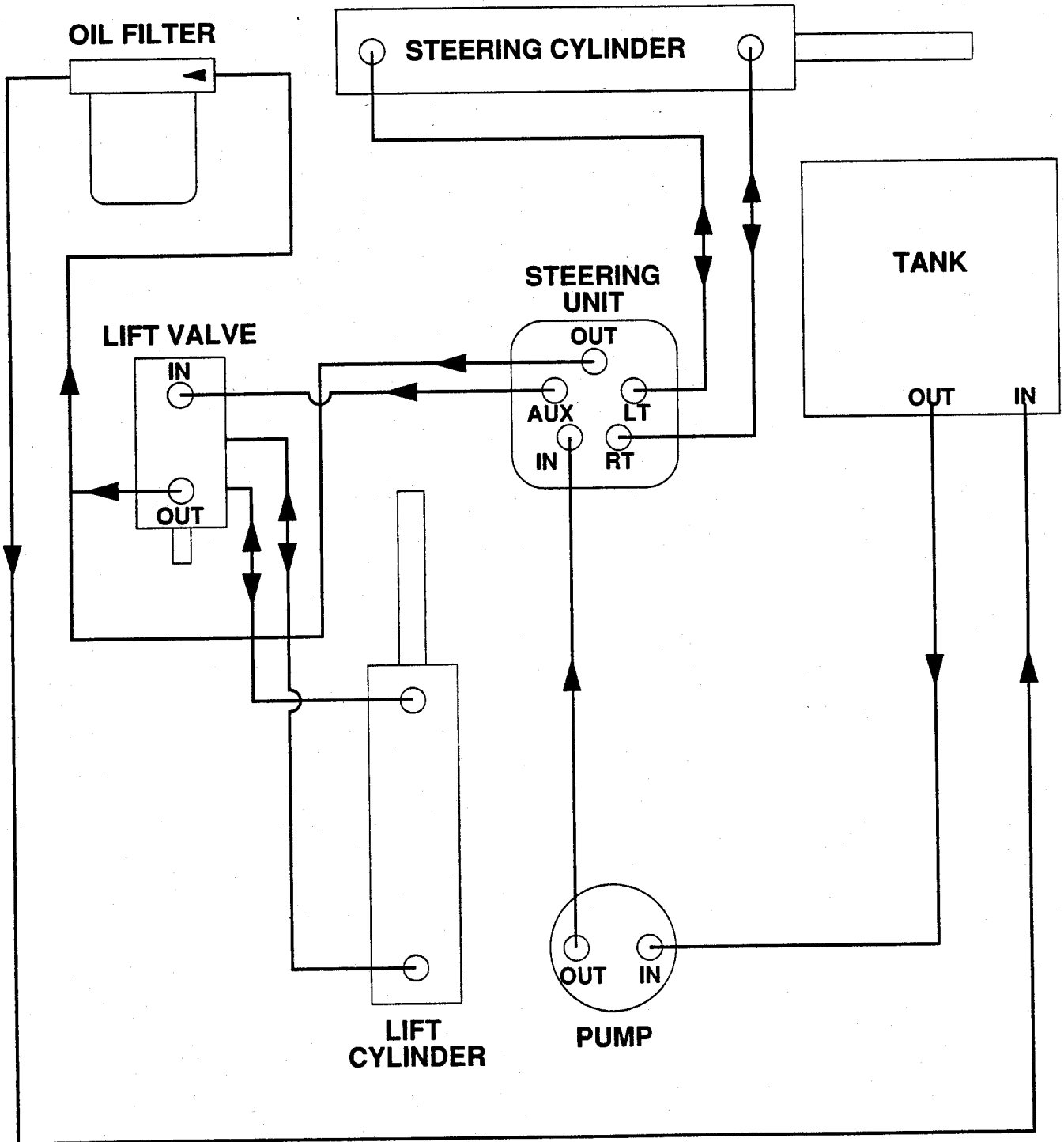

SECTION 8

SET-UP INSTRUCTIONS

- 8.1 Remove the tractor from the shipping container.
- 8.2 Adjust the air pressure in the rear tires to 10 psi (69 kN/m²) to 14 psi (97 kN/m²).
- 8.3 Adjust the air pressure in the front tires to 14 psi (97 kN/m²) to 18 psi (124 kN/m²).
- 8.4 The steering wheel is shipped upside down on the steering wheel shaft. Remove the nut, flat washer and steering wheel from the steering wheel shaft. Put a film of grease on the steering serrations and put steering wheel in place on the shaft. Retain the steering wheel with the flat washer and nut which were previously removed. Put the steering wheel cover in place.
- 8.5 Fasten the seat to the seat springs with four 5/16-18x.75 hex bolts and 5/16 lock washers. Connect the seat switch wires.

SECTION 9

LIMITED FIVE-YEAR WARRANTY

1. This Limited Five-Year Warranty is issued by Gravely International, Inc., only to the original purchaser. If Gravely equipment is leased by Gravely, this Warranty shall extend also to the original lessee as if such lessee were the original purchaser.
2. Gravely warrants that all new equipment manufactured by Gravely ("Gravely Products") shall be free of defects in material and workmanship for the term described in paragraph 4, below. Except as hereinafter provided, this Warranty does not cover any engine, tires or battery forming a part of the Gravely Product. Engine and tires are covered by and subject to separate warranties of the manufacturers thereof.
3. In the event that any Gravely Product warranted hereunder shall be defective or fail to conform with this Warranty, Gravely shall, subject to the provisions hereof, pay for, or provide labor and materials for, the repair or replacement of such defective Gravely Product.
4. This Warranty is for five years (60 months) from purchase date for Gravely Products used exclusively for personal, family or household purposes, and two years (24 months) for products used for other purposes (commercial use), excluding rental firms. Gravely products used for rental purposes will be warranted for 90 days. Repair of Gravely Products after the second year (24 months from date of purchase) shall be subject to a \$50.00 deductible for each repair. (After two years, Gravely agrees to repair or replace defective Gravely Products used exclusively for personal, family or household purposes only to the extent that the cost of such warranty covered repair or replacement exceeds \$50.00.)

Batteries are warranted by Gravely for a period of twelve (12) months only. If a battery shall fail within twelve (12) months of purchase, the replacement cost thereof shall be prorated over a twelve-month term based upon the number of months since purchase.
5. To obtain Warranty Service on a Gravely Product (including any battery or other component not manufactured by Gravely), use this procedure:
 - a. Notify the Gravely dealer from whom you purchased the equipment.
 - b. If you have moved and it is not convenient to notify the selling dealer, notify the nearest Gravely dealer. You should supply this dealer with a copy of the bill of sale as proof of the date of purchase.
 - c. Make arrangements to have the equipment delivered to the dealer (refer to paragraph 6 a., below).
 - d. If you have any questions concerning the Gravely Limited Warranty, they should be referred to:

Gravely International, Inc.
One Gravely Lane
Clemmons, NC 27012
Attn: Customer Service Department
 - e. Warranty Service on Gravely Products must be performed by an authorized Gravely dealer.
6. This Warranty does not cover the following:
 - a. Transportation to the Gravely dealership. (If the Gravely dealer provides transportation, he will charge for such service.)
 - b. Normal maintenance services and normal replacement of items such as spark plugs, belts, oil, oil filters, air filters, and mower, plow or cultivator blades, gauge wheels, skids and other wear items.
 - c. Any Gravely Product which has been altered or modified in any way.
 - d. Any repair or replacement occasioned by customer neglect or lack of proper maintenance. (The purchaser is responsible for making sure that Gravely Products are operated and serviced as directed in the applicable manual or service instruction. Incorrect use or maintenance will void this Warranty.)
 - e. Any repair occasioned by the use of any attachment not approved by Gravely. (The use of any such unapproved attachment will void this Warranty.)
7. GRAVELY MAKES NO OTHER EXPRESSED OR IMPLIED WARRANTIES, OR WARRANTIES AS TO THE MERCHANTABILITY OR FITNESS FOR A PARTICULAR PURPOSE. ALL WARRANTIES ARE LIMITED IN DURATION TO THE TERMS SET OUT IN PARAGRAPH 4, ABOVE. GRAVELY SHALL HAVE NO LIABILITY FOR INCIDENTAL OR CONSEQUENTIAL DAMAGES RESULTING FROM THE BREACH OF ANY WARRANTY, INCLUDING, BUT NOT LIMITED TO, LIABILITY FOR INCONVENIENCE, RENTAL OR PURCHASE OF REPLACEMENT EQUIPMENT, OR FOR LOSS OF PROFITS OR OTHER COMMERCIAL LOSS.
8. Some states do not allow limitations on how long an implied warranty lasts, so the above statement may not apply to you. Some states do not allow the exclusion or limitation of incidental or consequential damages, so the above limitation or exclusion may not apply to you.
9. This Warranty gives you specific legal rights, and you may have other rights which vary from state to state.
10. A Gravely product registration card is supplied with each Gravely Product. Please complete the card and return it to Gravely at the address listed on the card. The equipment registration card will be used by Gravely for:
 - a. Recording date of purchase.
 - b. Notification of owners in compliance with the Consumer Product Safety Act, should any notification be necessary.The return of such card is necessary for your warranty to be effective.
11. This Warranty is not subject to change or modification by anyone, including Gravely dealers and no Gravely dealer is authorized to make any representations or promises on Gravely's behalf.

 **GRAVELY**

One Gravely Lane, Clemmons, NC 27012