

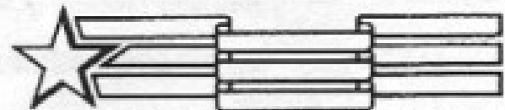

Ingersoll

**MANUAL STEERING AND FRONT AXLE
ALL MODELS
Service Manual No. 9-50392**



QUALITY IN THE AMERICAN TRADITION

Ingersoll Equipment Co., Inc.

Winneconne, Wisconsin 54986-9576

MYTRACTORFORUM.COM

FRONT AXLE AND STEERING GEAR SERVICE MANUAL

GENERAL

Manual steer compact tractors have a pinion and sector type of steering gear to transfer the operators steering effort through the drag link, upper spindle arm and tie rod to the spindles and wheels.

DISASSEMBLY

A. STEERING WHEEL (Early Production)

1. Pry steering wheel cap out being careful not to break off anchor tabs.
2. Remove hold down nut with proper socket wrench.
3. Pull steering wheel off and remove washer(s).

STEERING WHEEL (Late Production)

1. Remove roll pin.
2. Pull steering wheel off and remove out washers.

B. STEERING SHAFT

1. Remove woodruff key from top of shaft. (Early Production)
2. Remove steering shaft from bottom of tractor except on loaders where it is necessary to loosen the two set screws which hold the shaft to the "U" joint, and then pull the shaft out the top. Then remove snap ring from "U" joint mounting pin and remove washers and "U" joint.

C. SECTOR GEAR

1. Remove drag link ball joint from sector gear.
2. Remove Sector Gear:

100 AND 2000 SERIES

- a. Remove the two bolts which hold the sector gear pivot pin to the frame and remove gear.

200 AND 400 SERIES (Early Production)

- a. Remove the gear retaining bolt from the end of the gear mounting pin, and remove gear.

200 AND 400 SERIES (Late Production)

3000 AND 4000 SERIES

- a. Remove center access panel from steering tower.
- b. For 3000 and 4000 series tractors remove plastic belly pan.
- c. Remove the gear retaining locknut and remove gear. (Be sure to install a new locknut on re-assembly.)

600 SERIES

- a. On the loaders remove the snap ring which holds the gear to the mounting pin and remove the gear.

NOTE: STEERING GEAR MOUNTING BRACKETS CAN BE REMOVED FROM ALL MODELS BY REMOVING THE RESPECTIVE RETAINING BOLTS.

D. SECTOR GEAR PIVOT PIN

200 AND 400 SERIES (Early Production)

1. The sector gear pivot pin is threaded into the mounting bracket and can be removed.

200 AND 400 SERIES (Late Production) 3000 AND 4000 SERIES

1. The sector gear pivot pin is pressed into the mounting bracket, and can be pressed out to remove.

E. SPINDLES (Block tractor up at frame)

1. Remove tie rod ball joints from spindle arms.
2. Remove drag link ball joint from spindle steering arm.
3. Remove Spindles:

100 SERIES (Early Production)

- a. Remove steering arm retaining bolt, remove steering arm and key. Remove spindle.

**100 SERIES (Late Production)
2000 SERIES**

- a. Remove roll pin from steering arm, remove steering arm, and spindle.

200 AND 400 SERIES (Early Production)

- a. Remove roll pin from spindle, remove spindle.

**200 AND 400 SERIES (Late Production)
3000 AND 4000 SERIES**

- a. Remove snap ring from spindle, remove spindle.

600 AND 6000 SERIES

- a. Remove steering arm retaining bolt, remove steering arm, and (key on early production). Remove spindle.
4. Remove roll pin, or snap ring, and remove remaining spindle.

F. AXLE (Block tractor up at frame)

1. Support axle on blocks.
2. Remove axle:

100 SERIES

- a. Remove roll pin from rear of axle pin. (107 and 117 did not require a roll pin). Put drift pin in axle pin hole to keep axle pin from rotating. Remove nut from axle pin.
- b. Tap pin out of axle from front with drift.

**200, 400, 600 SERIES
2000, 3000, 4000, 6000 SERIES**

- a. Remove retaining bolt from tab on axle pin or remove bolt and axle pin retainer.
- b. Pull pin out or tap from behind with drift.
- c. Remove axle.

INSPECTION

Thoroughly clean all parts before inspection.

Inspect bushings, washers, pins, gears, ball joints, and spindles. Replace all damaged or worn parts.

ASSEMBLY AND INSTALLATION

A. AXLE

107 AND 117

- a. Position axle, install axle pin and secure with new lock nut.

100 SERIES (Except 107, 117)

- a. Position axle install axle pin and secure with new lock nut. Install roll pin in rear of axle pin.

200, 400, 600 SERIES

2000, 3000, 4000, 6000 SERIES

- a. Position axle, install pin, and secure with bolt or install axle pin, axle pin retainer and secure with bolt.

B. SPINDLES

1. Place one shim washer on each spindle then place spindle into axle and secure.
2. Spindles should be shimmed to remove end play. This is done by adding shims between the axle and roll pin or snap ring, and between the axle and the steering arm on models with removable steering arm. Add washers until you have a minimum amount of end play.
3. Install tie rod between spindles.

C. STEERING GEAR

1. Install mounting bracket in reverse of removal procedure.
2. Install respective sector gears in reverse of removal procedure.
3. Install steering shafts and steering wheels in reverse of removal procedure.
4. Re-connect drag link.

NOTE: 200 AND 400 SERIES (Late Production)
3000 AND 4000 SERIES

BE SURE TO INSTALL A NEW LOCKNUT
ON SECTOR GEAR MOUNTING BOLT.

SPECIFICATIONS

00, 400, 600 SERIES
000, 4000, 6000 SERIES

Distance "A" must be 1/8" to 3/8" less than "B".

100 AND 2000 SERIES

Distance "A" must be 1/8" to 1/4" less than "B".

ADJUSTMENTS

NOTE: BOTH MEASUREMENTS—FRONT AND
REAR MUST BE TAKEN AT SPINDLE
HEIGHT ABOVE THE FLOOR.

A. MEASURING TOE-IN (All Models)

1. Locate the tractor on a hard level surface preferably concrete. Place the front wheels in a straight ahead position.
2. Make sure the front tire pressures are equal.
3. Starting at the front of leading edge of the front wheels, place a chalk mark on each tire center line in line with the spindle. Do the same at the rear or trailing edge of each front wheel.

B. TOE-IN ADJUSTMENT

1. Loosen both tie rod ball joint jam nuts.
2. Turn the tie rod as required to obtain correct toe-in. Retighten the jam nuts.

CAUTION: BE SURE TO USE A WRENCH ON
THE JAM NUT AND THE BALL
JOINT. FAILURE TO HOLD THE
BALL JOINT COULD CRACK, OR
BREAK OUT THE SIDE OF THE BALL
JOINT CASE.

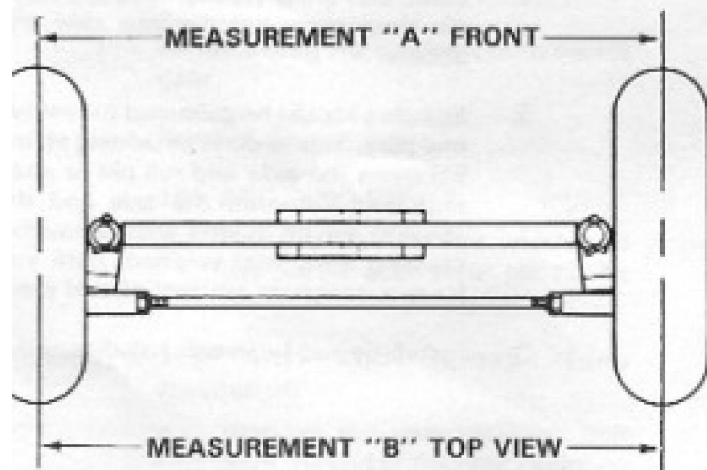

NOTE: THIS IS A DIAGRAM OF 100, 600, 2000
AND 6000 SERIES TRACTORS. THE TIE
ROD IS AHEAD OF THE AXLE ON THE
200, 400, 3000 AND 4000 SERIES
TRACTORS.

C. TURNING RADIUS

The turning radius should be approximately the same in both the right and left directions. To adjust the turning radius loosen both jam nuts on the drag link and turn the drag link in or out of the ball joints as required. One ball joint has left hand threads and the other right hand so it is not necessary to disconnect them from the steering arm and gear. Tighten the jam nuts when correct turning radius is obtained.

CAUTION: BE SURE TO USE A WRENCH ON THE JAM NUT AND THE BALL JOINT. FAILURE TO HOLD THE BALL JOINT COULD CRACK, OR BREAK OUT THE SIDE OF THE BALL JOINT CASE.

Properly adjusted, the pinion joint will be centered in the sector gear when the wheels are pointed straight ahead. This can be checked by counting the number of sector gear teeth on each side of the center meshed pinion joint tooth.

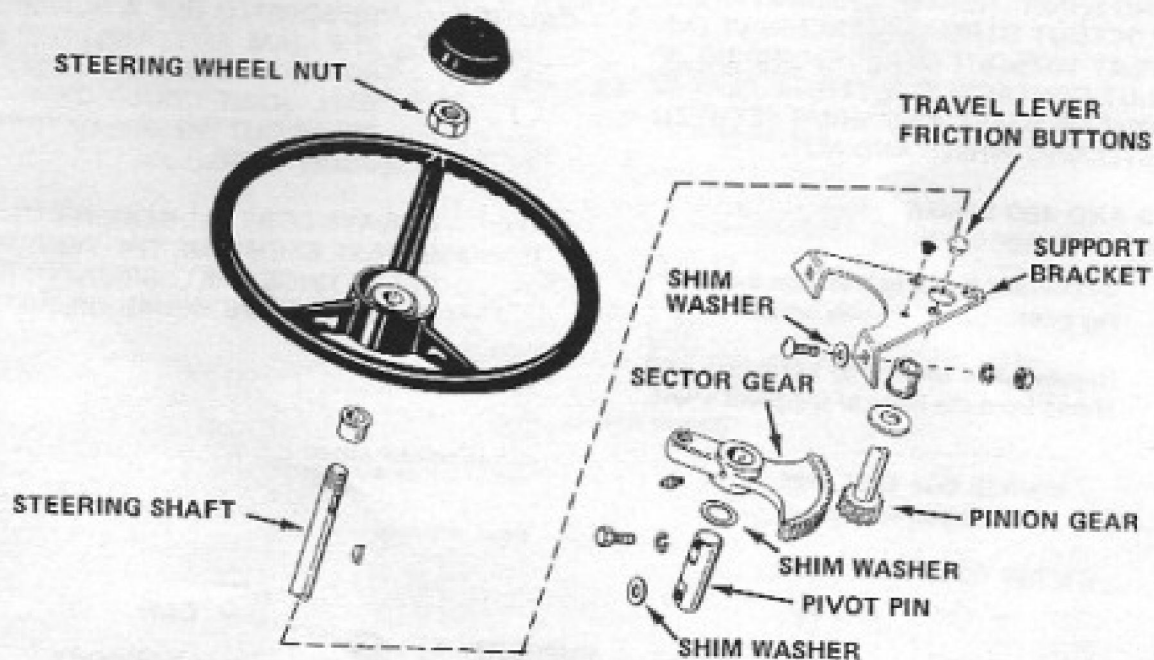

100 AND 2000 SERIES

D. STEERING GEAR ADJUSTMENT

100 AND 2000 SERIES

STEERING WHEEL NUT. The steering wheel nut is properly adjusted, when there is no end play on the steering shaft, and the pinion gear is in full alignment with the sector gear. Overtightening the nut can cause the pinion gear to bind against and distort the support bracket causing hard steering and travel lever operation.

SECTOR GEAR VERTICAL END PLAY. Vertical end play between the sector gear and the frame cutout should not exceed 1/16". If adjustment is necessary, shims can be added between the sector gear and the frame cutout. Check the alignment between the sector and pinion gears to determine whether the shims should be placed above or below the sector gear.

STEERING WHEEL FREE PLAY. Steering wheel free play should not exceed 2-1/2" at the outside diameter of the steering wheel. Excessive free play can be caused by loose or worn ball joints on the drag link and tie rod, or excessive clearance between the sector and pinion gears. The sector and pinion gears should mesh snugly without binding. To tighten the mesh between these gears, either equally remove shim washers between the support bracket and frame or equally add shim washers between the pivot pin and the frame.

IMPORTANT: EXCESSIVE STEERING WHEEL FREE PLAY MAY NOT REQUIRE GEAR ADJUSTMENT AS COVERED BELOW. FIRST CHECK TO MAKE CERTAIN ALL BALL JOINTS ON THE DRAG LINK AND TIE RODS ARE TIGHT.

NOTE: THE TRACTOR IS DESIGNED WITH TWO OR MORE SHIM WASHERS BETWEEN THE STEERING GEAR AND SUPPORT BRACKET AS ILLUSTRATED. AS THE GEAR TEETH WEAR IN, ADDITIONAL STEERING WHEEL FREE PLAY MAY OCCUR. IF THE FREE PLAY BECOMES EXCESSIVE, ONE (MORE IF NECESSARY) OF THE SHIMS CAN BE RELOCATED TO THE BOTTOM SIDE OF THE STEERING GEAR.

NOTE: FIRST MAKE CERTAIN THERE IS NOT EXCESSIVE END PLAY ON THE STEERING SHAFT. TIGHTEN STEERING WHEEL LOCKNUT TO REMOVE EXCESSIVE END PLAY WITHOUT CAUSING BINDING. IF NUT CONTACTS KEY BEFORE PLAY IS OUT OF SHAFT ADD SHIMS BETWEEN STEERING WHEEL AND NUT.

**200 AND 400 SERIES
3000 AND 4000 SERIES**

1. Disconnect the drag link from the steering gear.
2. Remove the mounting hardware and shims from the base of the pivot shaft.

3. Slip the steering gear and one of the shim washers off the pivot shaft.
4. Place the gear back on the pivot shaft and secure with the original mounting hardware (late production be sure to install a new locknut) shim(s) plus the shim removed from the upper side.

IMPORTANT: THE TOTAL NUMBER OF SHIM WASHERS MUST REMAIN THE SAME.

5. Re-connect drag link.

CAUTION: BE SURE TO USE A WRENCH ON THE JAM NUT AND THE BALL JOINT. FAILURE TO HOLD THE BALL JOINT COULD CRACK, OR BREAK OUT THE SIDE OF THE BALL JOINT CASE.

NOTE: ALWAYS COAT ALL GEAR TEETH WITH GREASE EACH TIME THE TWO STEERING FITTINGS ARE LUBRICATED OR AT LEAST EACH 25 HOURS OPERATION.

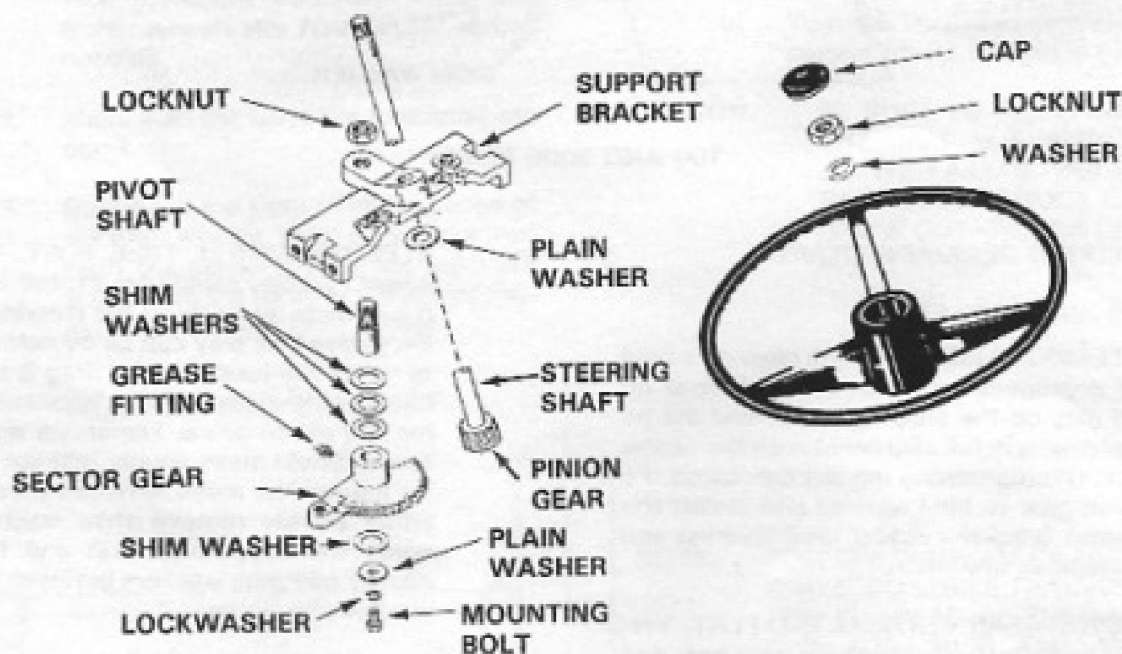

200 AND 400 SERIES
(Early Production)

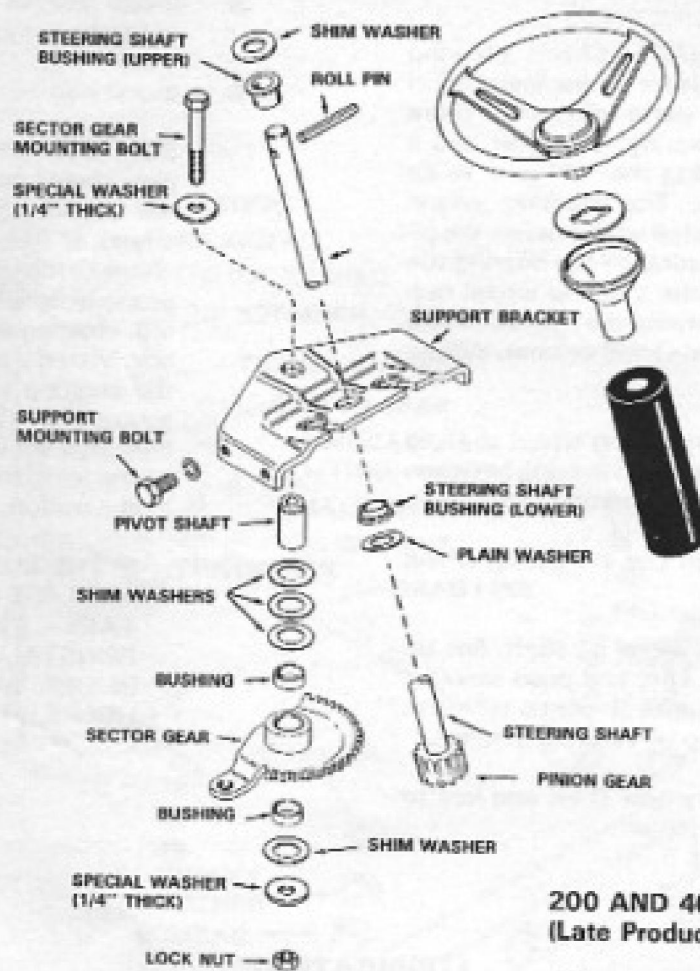

200 AND 400 SERIES
(Late Production)

3000 AND 4000 SERIES

LUBRICATION

100, 200 AND 400 SERIES
2000, 3000 AND 4000 SERIES

NOTE: ALWAYS WIPE DIRT FROM FITTING BEFORE APPLYING GREASE GUN.

Apply grease after every 25 HOURS of operation to:

1. Front wheel spindles

NOTE: LIFT FRONT OF TRACTOR TO PERMIT GREASE TO FLOW FROM TOP AND BOTTOM OF SPINDLE.

2. Front wheel bearings

NOTE: REMOVE DUST CAPS FROM FRONT WHEEL HUBS BEFORE GREASING FRONT WHEEL BEARINGS. THE TRAPPED AIR BEHIND THE DUST CAPS CAN PREVENT THE FULL LUBRICATION OF THE BEARINGS.

3. Axle pivot pin

4. Steering gear—apply a small amount of grease to the gear teeth.

Use number 1 multi-purpose grease (Lithium Base) for all lubrication fittings. Use as many strokes as required, until you see grease pushing out of assembly.

600 SERIES

STEERING SHAFT. Check steering wheel and shaft for proper installation according to parts diagram. There should be a bearing, a washer and a snap ring holding the "U" joint to its mounting pin. The steering wheel should be adjusted so that when the pinion gear is resting on the bearing the lower side of the steering wheel hub just barely contacts the nylon bushing on the top of steering column. Adjust as follows:

1. Push down on steering wheel shaft to be sure it is seated on bearing between pinion gear and mounting bracket.
2. Install woodruff key in steering wheel shaft.
3. Place steering wheel on shaft, line up key way with key, and push steering wheel down until it contacts nylon bushing on top of steering column.
4. Install washers over shaft and key to top of key or higher.

5. Install locknut and tighten until it just contacts washer.
6. Install cap.

STEERING WHEEL FREE PLAY. Free play should not exceed two inches at the outside diameter of the steering wheel. If free play is excessive, first check to make certain all ball joints are properly tightened to the king pins, tie rod, steering arm, sector gear and drag link. Visually check each pivot point in the steering system to determine the source of free play. Thrust washers and bushings are located at the front axle, pinion joint and sector gear as shown in illustration.

IMPORTANT: IF THE BUSHINGS IN THE FRONT AXLE ARE REPLACED, MAKE CERTAIN THE SPACERS ARE REINSTALLED WITH THE "SPLIT" IN LINE WITH THE LUBRICATION HOLES.

LUBRICATION

600 SERIES

NOTE: ALWAYS WIPE DIRT FROM FITTING BEFORE APPLYING GREASE GUN.

Apply grease after every 25 Hours of operation to:

1. Front wheel spindles (King pins)

NOTE: LIFT FRONT OF TRACTOR TO PERMIT GREASE FLOW FROM TOP AND BOTTOM OF SPINDLE.

2. Axle pivot pin.
3. Steering gear—apply a small amount of grease to the gear teeth.

Apply a few drops of oil to the pinion joint pivot pin.

STEERING COLUMN
KEY

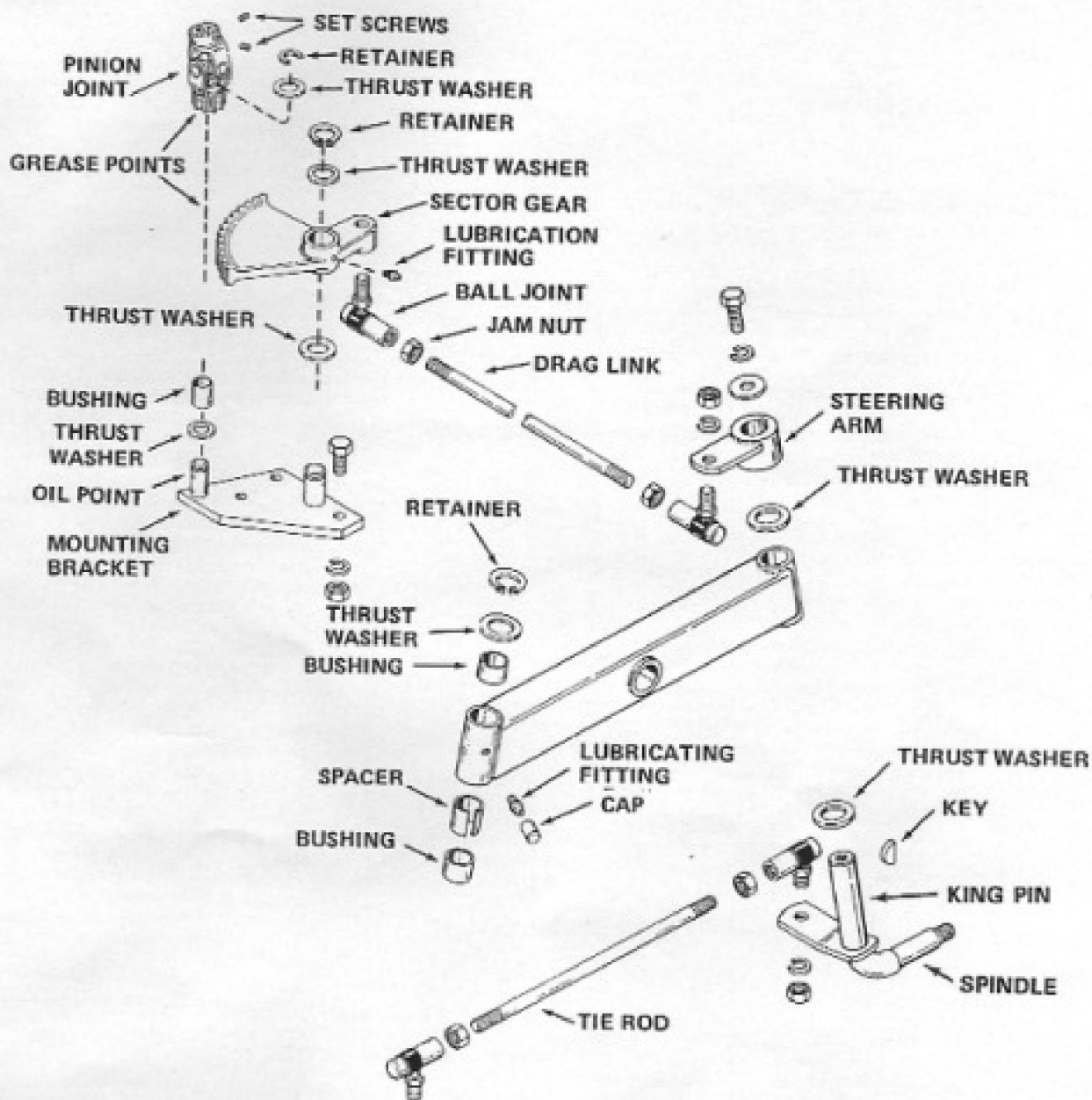

600 SERIES